

2021 (2022) I.C.T Marking Scheme

PAPERMASTER.LK

1 Marking instructions

விடைத்தாள்களுக்குப் புள்ளியிடல் - பொது நுட்ப முறைகள்

விடைத்தாள்களுக்குப் புள்ளியிடும் போதும், புள்ளிப்பட்டியலில் புள்ளிகளைப் பதியும் போதும் ஓர் அங்கீகரிக்கப்பட்ட முறையைக் கடைப்பிடித்தல் கட்டாயமானதாகும். அதன்பொருட்டு பின்வரும் முறையில் செயற்படவும்.

1. விடைத்தாள்களுக்குப் புள்ளியிடுவதற்கு சிவப்பு நிற குமிழ்முனை பேனாவை பயன்படுத்தவும்.
2. சகல விடைத்தாள்களினதும் முதற்பக்கத்தில் உதவிப் பரீட்சகரின் குறியீட்டெண்ணைக் குறிப்பிடவும். இலக்கங்கள் எழுதும்போது தெளிவான இலக்கத்தில் எழுதவும்.
3. இலக்கங்களை எழுதும்போது பிழைகள் ஏற்பட்டால் அவற்றைத் தனிக்கோட்டினால் கீறிவிட்டு, மீண்டும் பக்கத்தில் சரியாக எழுதி, சிற்றொப்பத்தை இடவும்.
4. ஒவ்வொரு வினாவினதும் உபபகுதிகளின் விடைகளுக்காக பெற்றுக்கொண்ட புள்ளியை பதியும் போது அந்த வினாப்பகுதிகளின் இறுதியில் \triangle இன் உள் பதியவும். இறுதிப் புள்ளியை வினா இலக்கத்துடன் \square இன் உள் பின்னமாகப் பதியவும். புள்ளிகளைப் பதிவதற்கு பரீட்சகர்களுக்காக ஒதுக்கப்பட்ட நிரலை உபயோகிக்கவும்.

உதாரணம் - வினா இல 03

(i) ✓ 

(ii) ✓ 

(iii) ✓ 

(03) (i) $\frac{4}{5}$ + (ii) $\frac{3}{5}$ + (iii) $\frac{3}{5}$ = $\frac{10}{15}$

பல்தேர்வு விடைத்தாள் (துளைத்தாள்)

1. க.பொ.த.இ. தற் மற்றும் தகவல் தொழிநுட்பப் பரீட்சைக்கான துளைத்தாள் திணைக்களத்தால் வழங்கப்படும். சரியாக துளையிட்டு அத்தாட்சிப்படுத்திய துளைத்தாள் தங்களுக்கு கிடைக்கப்பெறும். அத்தாட்சிப்படுத்திய துளைத்தாளைப் பயன்படுத்துவது பரீட்சகரின் கடமையாகும்.
2. அதன் பின்னர் விடைத்தாளை நன்கு பரிசீலித்துப் பார்க்கவும். ஏதாவது வினாவுக்கு, ஒரு விடைக்கும் அதிகமாக குறியிட்டிருந்தாலோ, ஒரு விடைக்காவது குறியிடப்படாமலிருந்தாலோ தெரிவுகளை வெட்டிவிடக்கூடியதாக கோடொன்றைக் கீறவும். சில வேளைகளில் பரீட்சார்த்தி முன்னர் குறிப்பிட்ட விடையை அழித்துவிட்டு வேறு விடைக்குக் குறியிட்டிருக்க முடியும். அவ்வாறு அழித்துள்ள போது நன்கு அழிக்காது விட்டிருந்தால், அவ்வாறு அழிக்கப்பட்ட தெரிவின் மீதும் கோடடிடவும்.
3. துளைத்தாளை விடைத்தாளின் மீது சரியாக வைக்கவும். சரியான விடையை ✓ அடையாளத்தாலும் பிழையான விடையை ○ அடையாளத்தாலும் இறுதி நிரலில் அடையாளமிடவும். சரியான விடைகளின் எண்ணிக்கையை அவ்வவ் தெரிவுகளின் இறுதி நிரையின் கீழ் அத்துடன் அவற்றை சட்டி சரியான புள்ளியை உரிய கட்டத்தில் எழுதவும்.

கட்டமைப்பு கட்டுரை விடைத்தாள்கள்

1. பரீட்சார்த்திகளால் விடைத்தாளில் வெறுமையாக விடப்பட்டுள்ள இடங்களையும், பக்கங்களையும் குறுக்குக் கோடிட்டு வெட்டிவிடவும். பிழையான பொருத்தமற்ற விடைகளுக்குக் கீழ் கோடிடவும். புள்ளி வழங்கக்கூடிய இடங்களில் ✓ அடையாளமிட்டு அதனைக் காட்டவும்.
2. புள்ளிகளை ஓவலண்ட் கடதாசியின் இடது பக்கத்தில் குறிக்கவும்.
3. சகல வினாக்களுக்கும் கொடுத்த முழுப் புள்ளியை விடைத்தாளின் முன் பக்கத்திலுள்ள பொருத்தமான பெட்டியினுள் வினா இலக்கத்திற்கு நேராக 2 இலக்கங்களில் பதியவும். வினாத்தாளில் உள்ள அறிவுறுத்தலின் படி வினாக்கள் தெரிவு செய்யப்படல் வேண்டும். எல்லா வினாக்களினதும் புள்ளிகளும் முதல் பக்கத்தில் பதியப்பட்ட பின் விடைத்தாளில் மேலதிகமாக எழுதப்பட்டிருக்கும் விடைகளின் புள்ளிகளில் குறைவான புள்ளிகளை வெட்டி விடவும்.
4. மொத்த புள்ளிகளை கவனமாக கூட்டி முன் பக்கத்தில் உரிய கூட்டில் பதியவும். விடைத்தாளில் வழங்கப்பட்டுள்ள விடைகளுக்கான புள்ளியை மீண்டும் பரிசீலித்த பின் முன்னால் பதியவும். ஒவ்வொரு வினாக்களுக்கும் வழங்கப்படும் புள்ளிகளை உரிய விதத்தில் எழுதுவும்.

புள்ளிப்பட்டியல் தயாரித்தல்

இம்முறை சகல பாடங்களுக்குமான இறுதிப்புள்ளி குழுவினுள் கணிப்பிடப்படமாட்டாது. இது தவிர ஒவ்வொரு வினாப் பத்திரத்துக்குமான இறுதிப்புள்ளி தனித்தனியாக புள்ளிப்பட்டியலில் பதியப்பட வேண்டும். பத்திரம் I ற்கான பஸ்தேர்வு வினாப் பத்திரம் மட்டும் இருப்பின் புள்ளிகள் இலக்கத்திலும் எழுத்திலும் பதியப்பட வேண்டும். 51 சித்திரப் பாடத்திற்குரிய I, II, மற்றும் III ஆம் வினாப் பத்திரங்களுக்குரிய புள்ளிகளை தனித்தனியாக புள்ளிப்பட்டியலில் பதிந்து எழுத்திலும் எழுத்துல் வேண்டும்.

0 0 0

3 Paper I answers

Department of Examinations - Sri Lanka

Confidential

ශ්‍රී ලංකා විභාග දෙපාර්තමේන්තුව
இலங்கைப் பரீட்சைத் திணைக்களம்
අ.පො.ස. (උ.පෙළ) විභාගය/ க.பொ.த. (உயர் தர)ப் பரீட்சை - 2020 2021
වව් කිරීමේදී/ புதிய பாடத்திட்டம்

විභාග අංකය
பரீட்சை இலக்கம் **20**

විභාග
பாடம் **ICT**

ලකුණු දීමේ පටිපාටිය/புள்ளி வழங்கும் திட்டம்
I පත්‍රය/பத்திரம் I

ප්‍රශ්න අංකය வினா இல.	පිළිතුරු අංකය விடை இல.	ප්‍රශ්න අංකය வினா இல.	පිළිතුරු අංකය விடை இல.	ප්‍රශ්න අංකය வினா இல.	පිළිතුරු අංකය விடை இல.	ප්‍රශ්න අංකය வினா இல.	පිළිතුරු අංකය விடை இல.	ප්‍රශ්න අංකය வினா இல.	පිළිතුරු අංකය விடை இல.
01.	3	11.	4	21.	2	31.	5	41.	2
02.	4	12.	4	22.	1	32.	5	42.	2
03.	4	13.	5	23.	5	33.	4	43.	4
04.	5	14.	1	24.	2	34.	3	44.	2
05.	4	15.	4	25.	2	35.	4	45.	4
06.	4	16.	3	26.	3	36.	3	46.	5
07.	4	17.	5	27.	4	37.	5	47.	5
08.	3	18.	5	28.	3	38.	5	48.	5
09.	2	19.	3	29.	1	39.	1	49.	4
10.	2	20.	5	30.	5	40.	2	50.	3

⊙ විශේෂ උපදෙස්/ விசேஷ அறிவுறுத்தல் :

එක් පිළිතුරකට/ ஒரு சரியான விடைக்கு ලකුණු 01
එක පිළිතුරකට/ ஒரு சரியான விடைக்கு 1 × 50 = 50

20 - Information & Communication Technology (Marking Scheme) (NEW Syllabus) / G.C.E. (A/L) Examination - 2020/ Amendments to be included. 4

PAPERMASTER.LK

5 Paper II mark scheme

Notes

1. Essential keywords sufficient for credit in some answers are underlined.
2. Acceptable alternatives for a given word or set of words are separated by slashes.
3. ←- A indicates that any credit for the item should be given only if A is correct.
4. **Rounding off of 0.5 marks** should only be done to the **final total** for Paper II.

1. (a) (i) Underline parts containing errors.

[2]

1.	<html>
2.	<body background-color="green">
3.	<h1> Welcome all of you to online ICT Seminar </h1>
4.	A/L Student Section
5.	<p> O/L ICT is not available
6.	←- Section 1 →
7.	<h4> A/L ICT </h4>
8.	<hr><p>Good Moming</p></hr>
9.	 <p> This section is for students </p>
10.	</body></html>

The above total mark is decided as follows:

2 marks for **4 or 5** places distinctly underlined

1 mark for maximum **1, 2 or 3** places distinctly underlined

NOTE:

▼ Deduct **1 mark** for one or more incorrect underlines.

▼ If everything is underlined, then **0 marks**.

- (ii) Write relevant code lines to make A/L Student Section (line 4) a hyperlink to A/L ICT (line 7). [1]

0.5 marks for each:

Line 4: ` A/L Student Section `

Line 7: `<h4 id = "one"> A/L ICT </h4>`

Or

Line 7: `<h4> A/L ICT </h4>`

Or

Line 7: `<h4> A/L ICT </h4>`

NOTE: HTML 5 does not support it.

h4 tag can be written as the outer tag as well. i.e.,

Line 7: `<h4> A/L ICT </h4>`

NOTES:

- ★ Instead of “one”, any other id (without spaces) can also be used on lines 4 and 7.
- ★ Quotes on lines 4 and 7 are essential.
- ★ Ignore space and case defects.

- (b) (i) Write a suitable cascading style sheet. [1]

0.5 marks for each line:

```
.art {font-size: 14px; text-align: center;}
```

```
h1 {color: yellow;}
```

NOTES:

- ▼ “art” must be in lower case as in question.
- ▼ If written within the `<body> ... </body>` or `<head> ... </head>`, then do **NOT** give marks.

- (ii) Write relevant HTML code lines to include style sheet to a web page. [1]

```
<head>  
<link rel="stylesheet" type="text/css" href="neat.css">  
</head>
```

NOTES:

- ★ “text/css” is optional.
- ▼ “stylesheet” has to be a single word.

(c) (i) Fill the blanks in the code.

[4]

```

<html><body>
<h2>Chess Tournament</h2>
<dl>
  <dt>Category I <ul><li>Team A</li><li>Team C</li> </ul> </dt>
  <dt>Category II<dd>Team B</dd><dd>Team D</dd></dt>
</dl>
<h3>Registration Form</h3>
<form method="get">
  <fieldset>
    <label for="Team">Select the team:</label>
    <select name="team">
      <option value="a">Team A</option>
      <option value="b">Team B</option>
      <option value="c">Team C</option>
      <option value="d">Team D</option>
    </select><br><br>
    <label for="comment">Your Comments:</label>
    <textarea name="comment" rows="3" cols="30"></textarea><br><br>
    <input type="checkbox" name="food">
    <label for="fr">Food Required</label>
    <input type="checkbox" name="accom">
    <label for="ar">Accommodation Required</label><br><br>
    <input type="submit" value="Submit">
  </fieldset>
</form>
</body></html>

```

0.5 marks allocated to each of the following:

- A: 2 dl tags
- B: 2 ul tags
- C: 4 dd tags
- D: 2 fieldset tags (▼ “fieldset” has to be a word.)
- E: 2 select tags
- F: 2 textarea tags (▼ “textarea” has to be a word.)
- G: 2 checkbox tags (▼ “checkbox” has to be a word.)
- H: 1 input tag

NOTES:

★ Ignore case.

- (ii) Write the relevant HTML code line to show "Team B" as the default selection. [1]

```
<option value="b" selected >Team B</option>
```

NOTES:

★ Ignore case in all **except** for "b".

2. (a) Write down the suitable cloud computing service type. [3]

1 mark for each:

- (i) Platform as a Service / PaaS
- (ii) Infrastructure as a Service / IaaS
- (iii) Software as a Service / SaaS

NOTE:

★ Ignore case.

- (b) Fill the blanks in the statements. [2]

0.5 marks for each:

- (i) Encryption
 - (ii) Phishing
 - (iii) Software piracy
- Copyright

NOTE:

★ Ignore case.

- (c) Write True, False or Cannot comment. [3]

1 mark for each:

- (technical feasibility) False
- (operational feasibility) True
- (organizational/institutional feasibility) Cannot comment

NOTE:

★ Ignore case.

- (d) (i) E-Business selling foods: B2B, B2C or C2C? [1]

B2C / Business to Consumer / Business to Customer

NOTE:

▼ Upper case needed for the abbreviated answer (i.e., B2C)

★ Ignore case for the other answer (i.e., Business to Consumer)

- (ii) What is the electronic payment service commonly called? [1]

payment gateway

NOTE:

★ Ignore case.

3. (a) Fill the four components in the flowchart.

[4]

1 mark for each correct component.

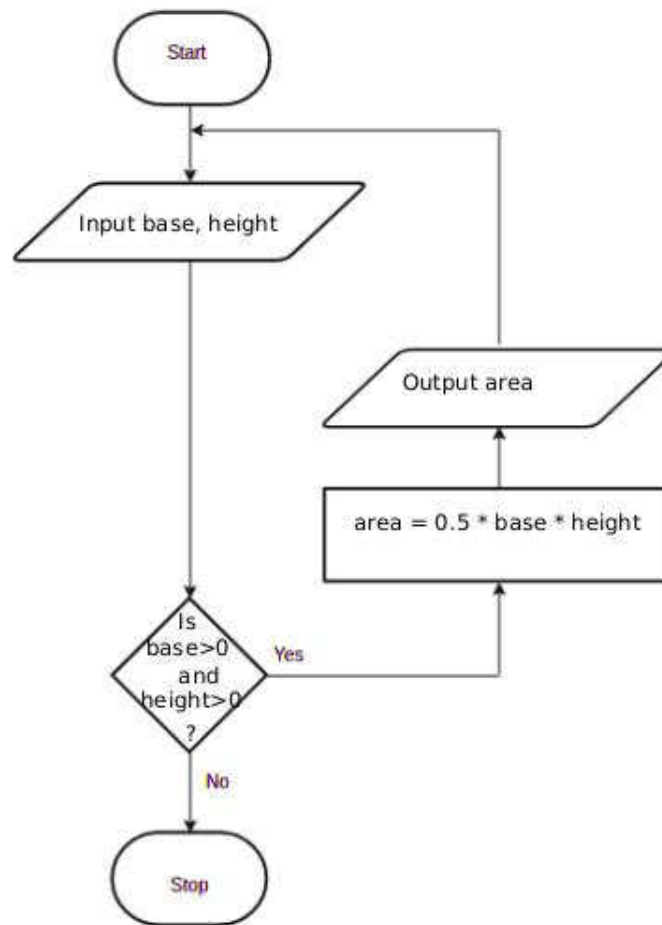

NOTES:

- ★ For “input”: any other word that conveys the meaning is acceptable. e.g., *get, read*
- ★ For “output”: any other word that conveys the meaning is acceptable. e.g., *display, print, show*
- ★ For condition: “is base and height > 0?” is also acceptable and “is”, “?” are not essential.
- ★ For variable names: b/B,h/H acceptable. Other meaningful names are also acceptable. If any other *single letter* is used for a variable, then it has to be defined.
- ▼ For credit for the output component to be given, it has to indicate displaying whatever was computed in the computation block.

- (b) Fill the four blanks in the factorial code. [4]

1 mark for each:

```
num
num == 0
factorial = factorial*i (correct indentation essential.)
factorial
```

NOTE:

- ★ “factorial *= i” is also acceptable for the third blank.
- ▼ Correct case essential.

- (c) Write the output of the python program. [2]

```
2
3
5
```

The above total mark is decided as follows:

- 2 marks** for the exact answer (with or without vertical alignment)
- 1 mark** for either 2 3 or 2,3,5 or 2,3

NOTES:

- ▼ Correct order important.

4. (a) Write down one functional requirement w.r.t. appointment scheduling. [1]

Any answer having the following meaning:

For any given hour, no more than 20 patients should be scheduled.

- (b) Give one non-functional requirement w.r.t. the validity check. [1]

Any answer having the following meaning:

The validity check should be done fast.

- (c) Write the suitable content numbers. [7]

P - 8 Q - 9 R - 1 S - 7 T - 4

U - 2 V - 3 W - 5 X - 6

The above total mark is decided as follows:

- 7 marks** for all 9 labels correct
- 6 marks** for maximum 8 labels correct
- 5 marks** for maximum 7 labels correct
- 4 marks** for maximum 5 or 6 labels correct
- 3 marks** for maximum 4 labels correct
- 2 marks** for maximum 3 labels correct
- 1 mark** for maximum 1 or 2 labels correct

(d) Give one difference between white box and black box testing.

[1]

Any **one** from the following:

White box	Black box
code remains visible to testers	code remains hidden from testers
a low-level testing that involves detailed testing of code	high-level testing that does not involve detailed program level testing
Generally done by developers	Generally done by independent testers/users
Design documents are usually used for testing	Specification document is required for testing
Tests the logic and implementation of software	Tests functionality of software
Programming knowledge and implementation details are required	Prior knowledge of programming is not required
Types of tests include path testing, control structure testing, loop testing, conditions testing	Types of tests: boundary value analysis, comparison tests etc
Generally testing tools depend on programming language	Generally testing tools are independent of programming language

NOTE:

▼ No partial marks. Comparison must involve both types.

5. (a) Show the complete truth table for the given circuit.

[2]

A	B	C	X
0	0	0	0
0	0	1	0
0	1	0	0
0	1	1	0
1	0	0	1
1	0	1	0
1	1	0	1
1	1	1	1

The above total mark is decided as follows:

- 2 marks for all 8 rows correct
 1.5 marks for maximum 5,6,7 rows correct
 1 mark for maximum 3,4 rows correct
 0.5 marks for maximum 1,2 rows correct

NOTE:

- ★ Having *Output* as the X column title is acceptable.
 ▼ If the X column is not labelled, or the label is different from X / *Output*, reduce 1 mark from the earned total.

- (b) Complete the Karnaugh map according to the given format.

[4]

0.5 marks for each correct cell:

		AB			
		00	01	11	10
C	0	0	0	1	1
	1	0	0	1	0

PAPERMASTER.LK

(c) Using the K map, derive a simplified SOP expression for X.

[3]

		AB			
		00	01	11	10
C	0	0	0	1	1
	1	0	0	1	0

$X = AB + A\bar{C}$

Marks allocated as follows:

A: **2 marks** for marking the two loops on the correct Karnaugh map (**1 mark** for each)

B: **1 mark** for correct, simplified final SOP expression as $X = AB + A\bar{C}$ (←-- A)

NOTE:

★ For component B, the term X is not compulsory.

(d) Using the K map, derive a simplified POS expression for X.

[3]

		AB			
		00	01	11	10
C	0	0	0	1	1
	1	0	0	1	0

$X = A(B + \bar{C})$

Marks allocated as follows:

A: **2 marks** for marking the two loops on the correct Karnaugh map (**1 mark** for each)

B: **1 mark** for correct, simplified final POS expression as $X = A(B + \bar{C})$ (←-- A)

NOTE:

★ For component B, the term X is not compulsory.

- (e) Out of the two expressions which one is better to implement a more simplified logic circuit than the given logic circuit? Explain. [3]

The POS, $X = A(B + \overline{C})$, is better than the SOP, $X = AB + A\overline{C}$.

Explanation:

With POS, we can implement a simpler logic circuit with one OR gate, one AND gate and one NOT gate (only three gates) whereas the SOP leads to a logic circuit with two AND gates, one OR gate and one NOT gate (four gates).

Marks allocated as follows:

A: **1 mark** for correctly identifying that the POS is better than the SOP

(←-- correct SOP and POS expressions for 5(c) and 5(d))

B: **2 marks** for correct explanation on why the POS is better than the SOP given as follows: (←-- A)

1 mark: POS has fewer (3) literals and leads to a logic circuit with 3 gates

1 mark: SOP has more (4) literals and leads to a logic circuit with 4 gates

or alternatively:

B: **2 marks** for correctly showing the two correct circuit diagrams and identifying the better one **or** for indicating generally that POS results in a circuit that has fewer gates when compared to the circuit resulting from SOP (←-- A)

IMPORTANT: Note the dependency in marking component **A**. This basically means **not** to give credit for part **(d)** if the student is not basing his/her argument using the expressions $X = AB + A\overline{C}$ and $X = A(B + \overline{C})$.

6. (a) Explain how the odd parity check could be used to detect any error in the transmission of 1010110. [2]

Marks allocated as follows:

A: 1 mark for adding 1 as the parity bit

B: 1 mark for receiver has to get the total number of bits odd;
if not error

NOTE:

★ Ignore the position where the parity bit is added.

- (b) Fill the empty entries in the IP address table. [6]

0.5 marks for each correct cell.

Division/ Unit	Network ID	Broadcast ID	Subnet Mask	No. of Nodes	Usable IP Address Range
Marketing	192.174.19.0	192.174.19.63	255.255.255.192	64	192.174.19.1- 192.174.19.62
Stores	192.174.19.64	192.174.19.79	255.255.255.240	16	192.174.19.65- 192.174.19.78
Supplies	192.174.19.96	192.174.19.111	255.255.255.240	16	192.174.19.97- 192.174.19.110
Operations		192.174.19.159		32	

IMPORTANT: **Any** or **no** answer to the three cells on the last row (Operations) is considered acceptable.

- (c) (i) Which network topology will you suggest for Mohan? [1]

ring

or alternatively

mesh

NOTE: **mesh** is acceptable as an answer. But may not be very beneficial due to extra interconnections needed, performance degradation and inadequate user requirement to go for a mesh.

(ii) Draw the logical arrangement of the network.

[2]

Ring:

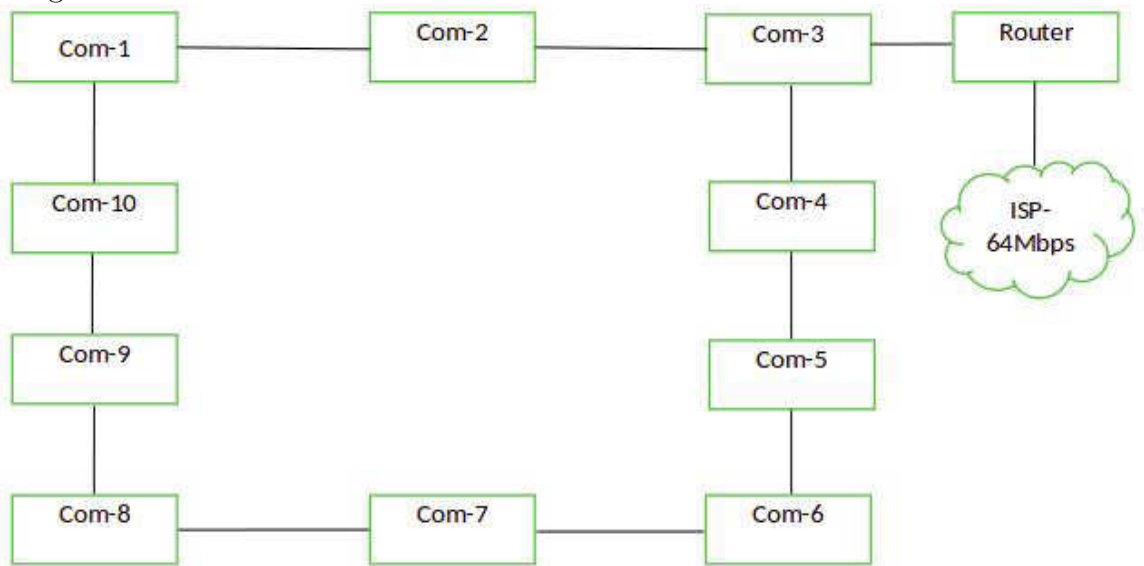

[if the student has chosen a mesh:]

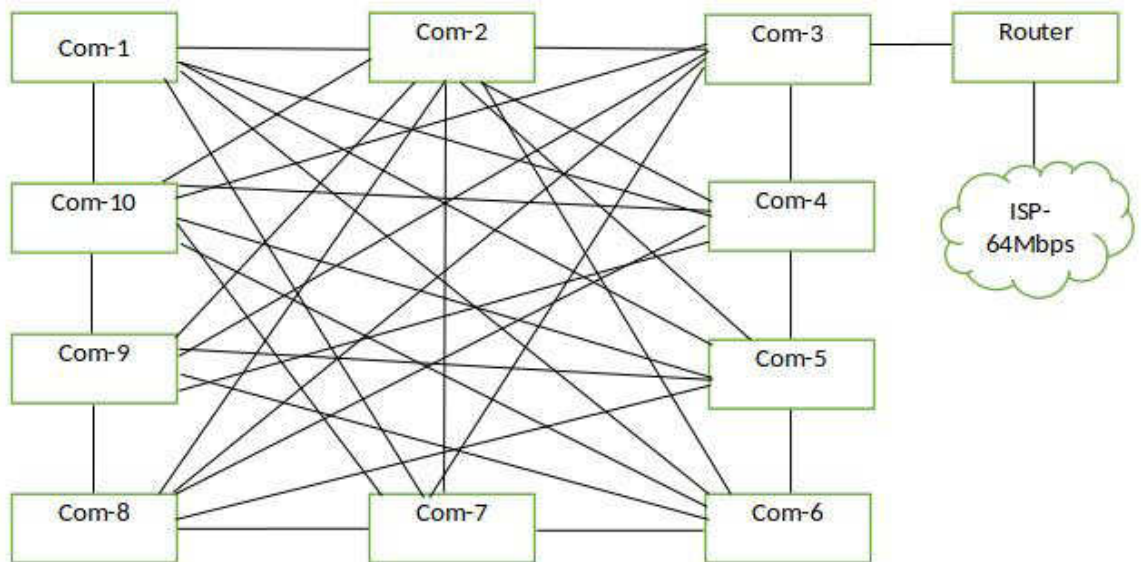



1 mark for each:

- A: 10 computers properly connected to Router /
10 computers properly connected to Router along with a firewall and/or proxy
(←-- topology chosen is either **ring** or **mesh**)
- B: Router connected to Internet connection

NOTES:

★ The following symbols are also accepted for this part and for part (v):

Router		Firewall
		

★ Instead of “ISP”, “Internet” is also acceptable.

PAPERMASTER.LK

(iii) Technical suggestion to improve connection speeds for clients. [1]

Add a Proxy Server

(iv) Mechanism to protect the network by filtering the communication traffic [1]

Have a firewall

(v) Include the solutions for (iii) and (iv) in the logical network arrangement. [2]

Ring:

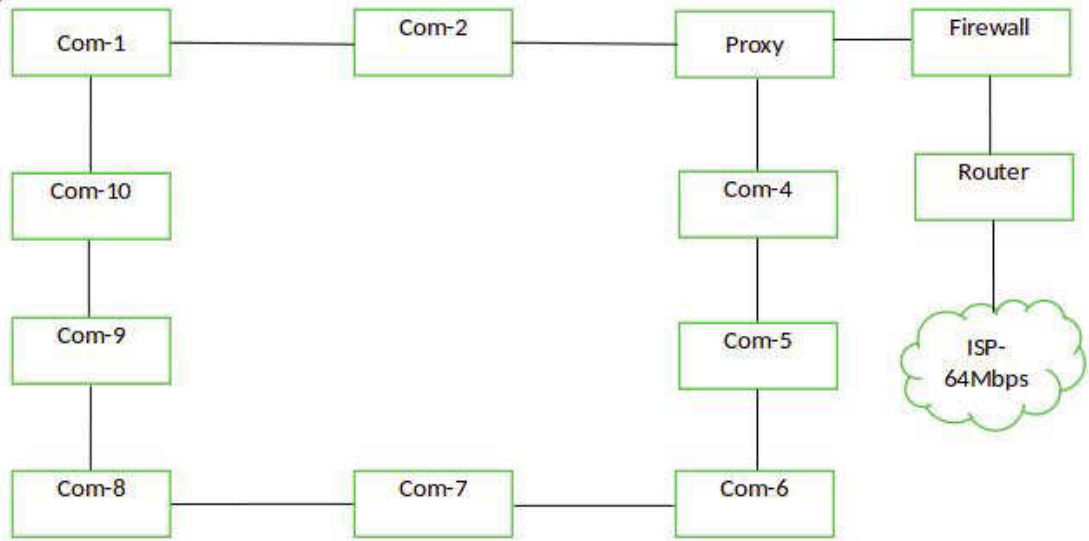

[if the student has chosen a mesh:]

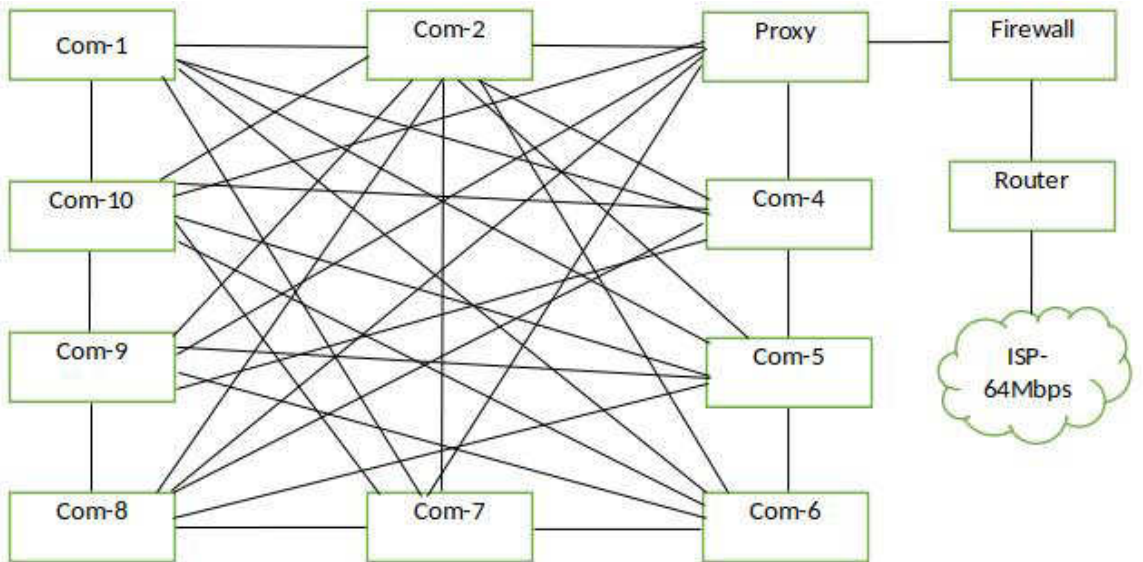

1 mark for each:

A: properly adding and labelling proxy (←-- topology chosen is either **ring** or **mesh**)

B: properly adding and labelling firewall

7. (a) (i) What is the ecommerce business type applicable in this scenario? [1]

B2C / Business to Consumer / Business to Customer

(ii) What is the revenue model used in this E-Commerce site? [1]

online sales

(iii) Do you recommend the same revenue model of (ii) for offering digital learning material? Justify. [1]

If **Yes**, then justification should relate the possibility of online sales as a revenue model for digital content.

If **No**, then justification should relate the challenges with online sales for the digital content (in that case, use subscription as a revenue model).

(iv) Suggest a strategy to increase the business revenue with the help of the proposed streaming channel. [1]

Advertisements as a revenue model or a suitable answer

(v) Write down a key challenge the bookshop has to face when implementing the digital content channel. [1]

Answer could be in the following themes with an explanation why it is important:

- **Cost-effectiveness:** giving *free* access to this service
- **Content quality:** Recording/preparation and editing must meet standards; reducing bandwidth consumption of the viewers
- **Copyright issues:** Should avoid improper use of IP/Copyright material within content and through the channel offering
- **Technical suitability:** Should provide uninterrupted service (availability); compatibility with many devices/browsers (compatibility), service efficiency, security, etc.

- (vi) Name a suitable expansion solution to incorporate both related and unrelated products or services. [1]

an E-Commerce market place / E-Marketplace /
On-line marketplace

- (b) (i) Draw a simplified agent diagram and name important entities and interactions. [6]

Entities: user/buyer, Chat-bot Agent/Chat-bot, Search-Agent, Domain Agent, Sub-agent

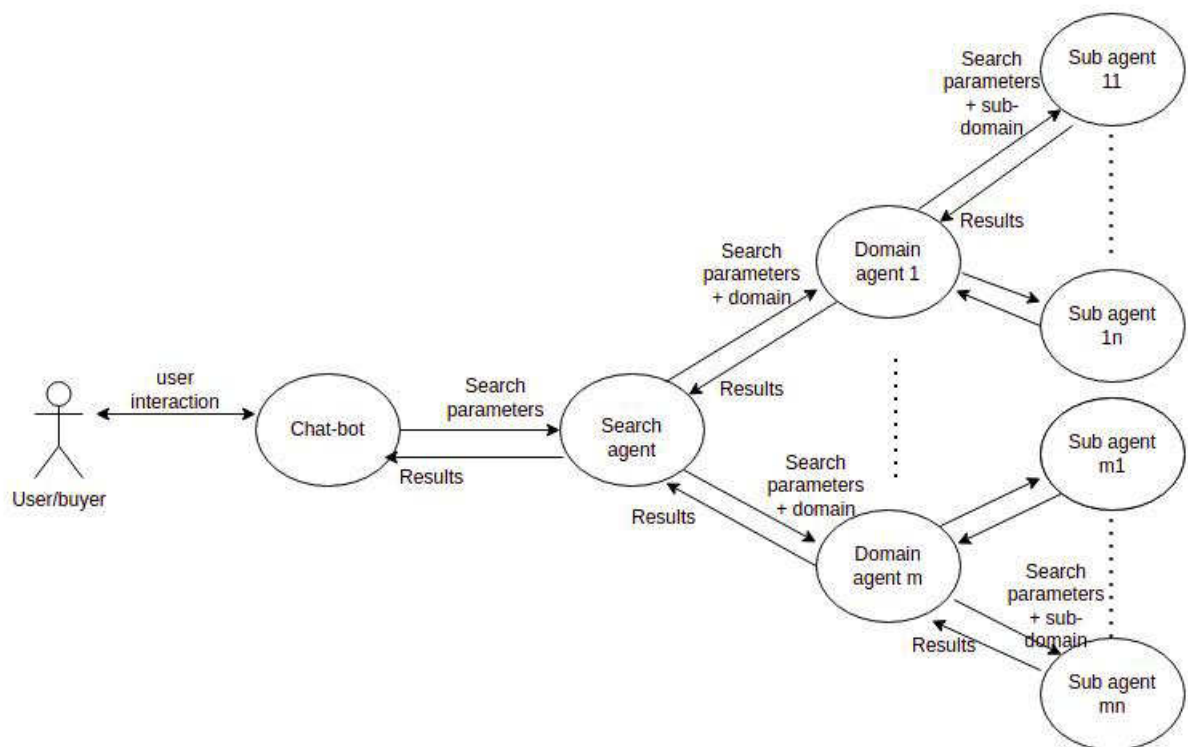

Marks allocated as follows:

- A: 1 mark for User to ChatBot Agent interaction (two-way arrow)
- B: 1 mark for ChatBot Agent to Search agent interaction (two-way arrow)
- C: 1 mark for Search Agent to Domain Agent interactions (two-way arrows)
- D: 1 mark for Domain Agent to Sub-agent interaction (two-way arrows)
- E: 1 mark for indicating *multiple* domain agents **and** *multiple* sub-agents
- F: 1 mark for describing all interactions correctly

NOTE:

- ★ If a student has included a *user interface*, ignore that additional information and mark as given in the scheme.
- ★ Describing **all** interactions along **only** one complete path from beginning to end is sufficient for F component above.

(ii) Write one major advantage of this multi-agent system. [1]

Any **one** from the following:

- Convenience to buyer: Buyer need not do the evaluation him/herself
- Increased speed of getting the result
- Buyer does not have to type lengthy description of his requirement as a Chat-bot helps
- Cost effectiveness for buyer as s/he need not physically visit multiple shops

(iii) Write one ICT related challenge when developing a sub-agent. [2]

Any **one** from the following:

- Information on different websites may be in different formats.
- Language processing may be required to extract information from sites.
- Information on different websites may be in different languages.
- Sub-agents should not take a long time to give the results.
- Two sub-agents should not search the same site through indirect access.

8. (a) Construct a flow-chart or pseudo-code to output the average age of students in L whose age is $< k$ years. [5]

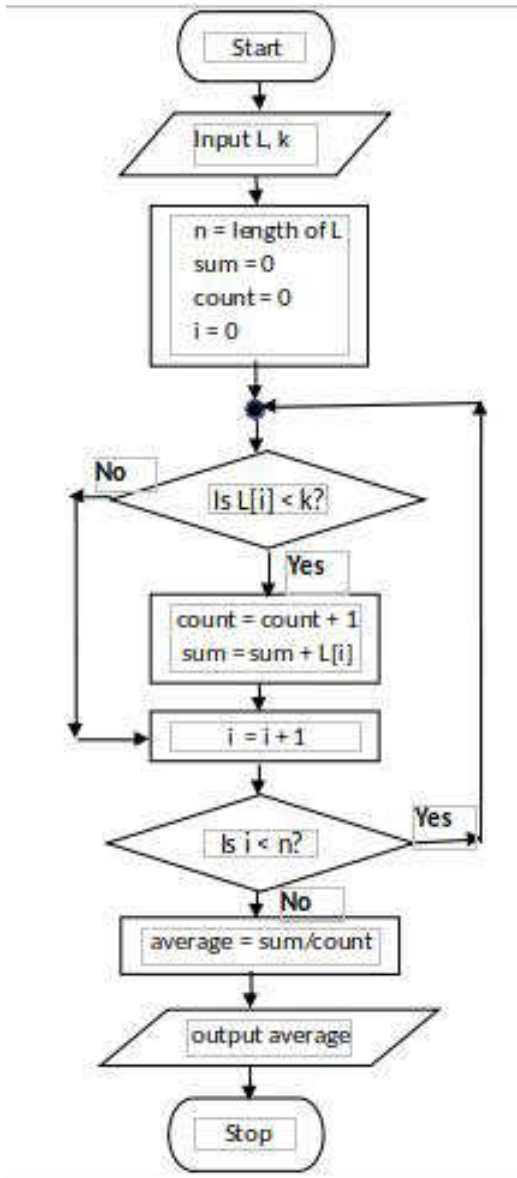

Using for-loop

```

input L, k
n = length of L
sum = 0
count = 0
for i = 0 to n
  if (L[i] < k)
    count = count + 1
    sum = sum + L[i]
  end-if
end-for
average = sum / count
output average
  
```

Alternative using while-loop

```

input L, k
n = length of L
sum = 0
count = 0
i = 0
while (i < n)
  if (L[i] < k)
    count = count + 1
    sum = sum + L[i]
  end-if
  i = i + 1
end-while
average = sum / count
output average
  
```

Marks allocated for either flowchart or pseudo-code as follows:

- A: **1 mark** for getting inputs correctly
- B: **1 mark** for correct $< n$ looping
- C: **1 mark** for correct computation (\leftarrow B)
- D: **1 mark** for correct output action (\leftarrow C)
- E: **1 mark** for completeness (\leftarrow D)

FLOWCHART: important arrows and correct symbols for start, stop, input/output, processes, conditions

PSEUDO-CODE: Begin-End, indentation

NOTE:

- ★ Acceptable synonyms: (Start, Begin), (Stop, End, Finish), (Input, Get, Read), (Output, Print, Show, Display) [ignore case]
- ★ n could also be a user input.
- ★ Loop index can go from 1 to n as well.

- (b) (i) What would be the output if L1 = 2,4,7,9,3,5 and L2 = 1,3,8,9,6,5,7? [2]

4 / Output = 4 / or anything similar to indicate the output is 4.

- (ii) What is the purpose of this algorithm? [2]

Output the number (count) of elements that are in both lists L1 and L2

Marks allocated as follows:

1 mark for the number (count) of elements that are in both lists L1 and L2

1 mark for displaying the result

- (iii) Develop a python program to implement the algorithm expressed by the flowchart. [6]

```
# Inputs: L1, L2 are non-empty lists of integers
#         Each of L1, L2 have unique elements (no duplicates)
# Output: number (count) of elements that are in both L1 and L2
#
inL1 = input("Enter the elements in L1: ")
L1 = [int(x) for x in inL1.split()]
inL2 = input("Enter the elements in L2: ")
L2 = [int(x) for x in inL2.split()]
count = 0
for i1 in L1:           // or for i1 in range(len(L1)):
    for i2 in L2:       // or for i2 in range(len(L2)):
        if i1 == i2:   // or if (L1[i1] == L2[i2]):
            count = count + 1
print(count)
```

Allocate marks as follows:

A: **1 mark** for getting inputs correctly

B: **1 mark** for correct outer loop

C: **1 mark** for correct inner loop (←-- B)

D: **1 mark** for correct if construct (←-- C)

E: **1 mark** for correct output printing (←-- D)

F: **1 mark** for correct indentation (←-- E)

9. (a) (i) Draw an ER diagram for the given description.

[7]

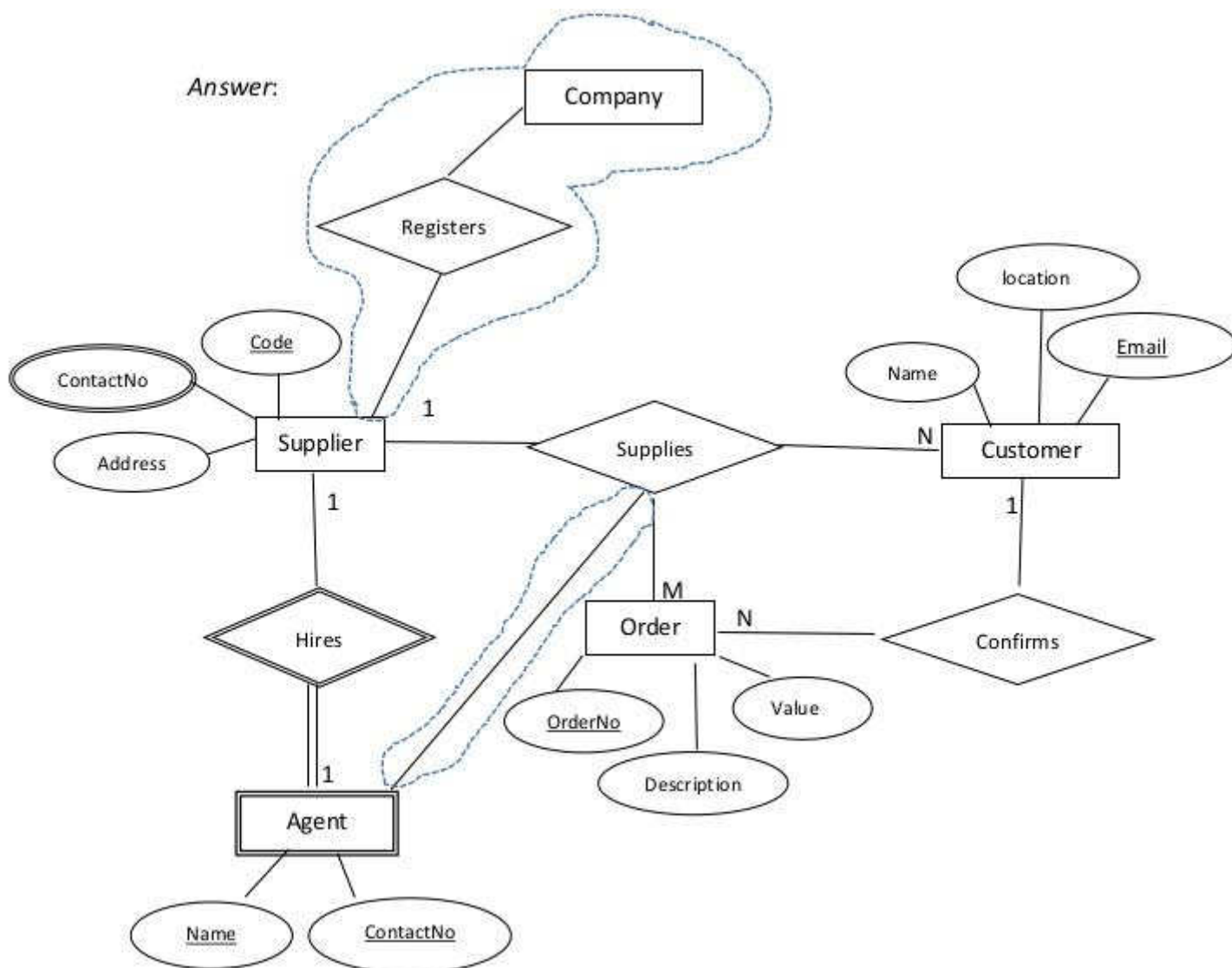

Marks allocated as follows:

- A: **3 marks** for the strong entities (*Supplier*, *Customer*, *Order* with correct attributes and primary keys marked (←-- correct entity and attribute symbols)
NOTE: **1 mark** for each entity
- B: **3 marks** for the relationships (*confirms*, *Supplies* [*Order and customer*], *Supplies* [*Supplier and customer*]) with correct cardinality
NOTE: **1 mark** for each relationship
- C: **1 mark** for *ContactNo* (multi-valued attribute)

NOTES:

- ★ Ignore case of letters.
- ★ Do NOT deduct marks if the student has drawn additional details which are shown within dotted enclosures.
- ▼ Deduct a maximum **1 mark** from the total earned mark if any other additional parts are drawn.
- ▼ If there is any spelling mistake (one or two letters) deduct **one mark** from the earned total. Naming entities in plural forms (e.g., suppliers) is also considered as spelling mistakes.

- (ii) Add the *agent* to the ER diagram. [4]

Marks allocated as follows:

- A: **1 mark** for [agent] being a weak entity
- B: **1 mark** for attributes of agent
- C: **1 mark** for *weak* relationship (total participation not necessary)
- D: **1 mark** for correct cardinality

- (b) (i) Write an SQL statement to change the mobile number of EP003 agent to 0772222222. [1]

```
UPDATE Contracts SET AMobile = '0772222222' WHERE  
ACode = 'EP003';
```

NOTES:

- ▼ Exact case is required for those that are underlined. Ignore case for the rest.
- ★ Ignore quotes in '0772222222'.
- ★ Ignore semicolon.

- (ii) In which normal form does the **Contracts** table exist? [1]

2NF / second normal form

- (iii) Convert the **Contracts** table to the next normal form.
(It is not required to write the data in the derived relations.) [2]

1 mark for each:

- A: **Contracts**(CNo, ACode, Client)
- B: **Agent**(ACode, AName, AMobile)

NOTES:

- ★ Ignore case.
- ★ Other meaningful names for “Contracts” and “Agent” relations also acceptable.
- ▼ The primary keys should be marked as shown.

10. (a) (i) Explain one way in which bar code technology can be beneficial to a library management system. [2]

Marks allocated as follows:

A: **1 mark** for fixing a bar code to each book

B: **1 mark** for explaining the benefit

- (ii) Explain one way in which multiple processors in computers can be beneficial. [2]

Any **one** from the following:

- When there are multiple processes that the user has started on the computers, they can run on the different processors simultaneously to finish everything quicker.
- Can be used for *parallel computing*; complicated tasks can be split to parts and the parts can be programmed to run on the different processors to finish everything quicker.

The above total mark is to be decided as follows:

Give the full **2 marks** if the answer is complete. Else, give **1 mark**.

- (iii) Explain what is meant by *volatile memory* and select an example from the list. [2]

Marks allocated as follows:

A: **1 mark** for explaining *volatile memory*: computer storage that only maintains its data while the device is powered

B: **1 mark** for any **one** from (Dynamic RAM (DRAM), L1 cache, Registers)

- (b) (i) How all applications “execute simultaneously” on a single processor computer? [3]

Marks allocated as follows:

A: **2 marks** - explaining the concept of multiprogramming / time sharing

B: **1 mark** - switching between processes happens fast

- (ii) How can the programs whose sizes are larger than physical memory could be run on a computer? [4]

The marks allocated as follows:

- A: **1 mark** for Entire program is not brought to physical memory at once
B: **1 mark** for Program stored in virtual memory / hard disk
C: **1 mark** for Program divided into ``pages''
D: **1 mark** for Pages are brought into physical memory when needed (←-- C)

- (iii) Why each file needs slightly more space in *linked allocation*? [2]

Marks allocated as follows:

- A: **1 mark** for Each block contains a pointer to the next block.
B: **1 mark** for That block takes some space. (←-- A)