



NEW & OLD

Department of Examinations - Sri Lanka
 G.C.E. (A/L) Examination - 2020

01 - Physics

New & Old Syllabus

Marking Scheme

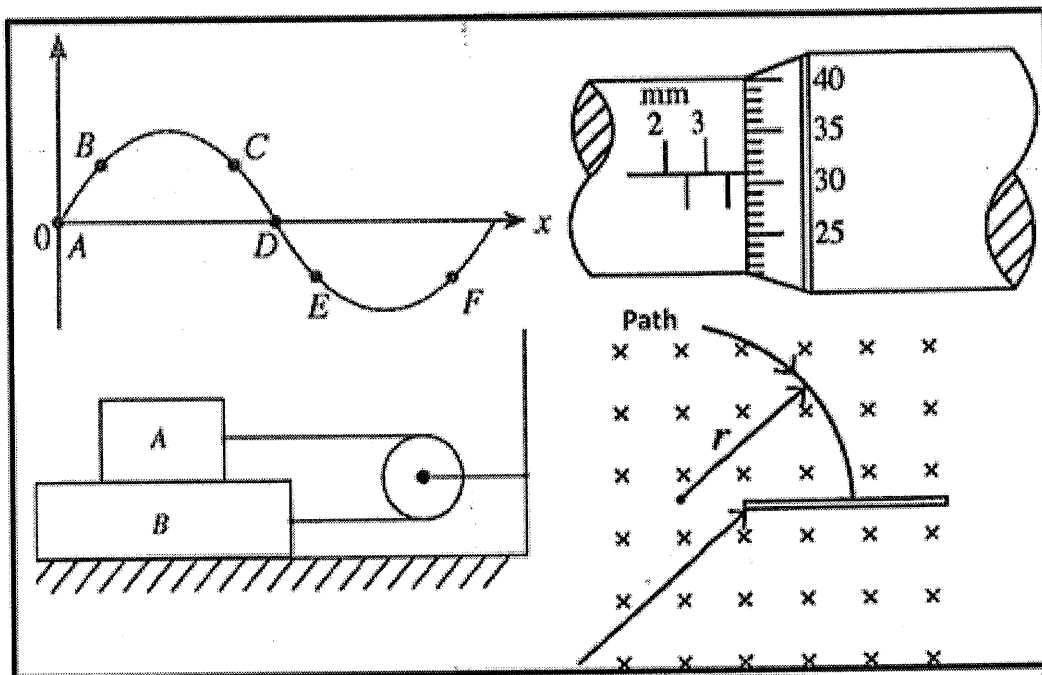

This document has been prepared for the use of Marking Examiners.

The Summary of distribution of marks in each question Paper

01. Paper I – $1 \times 50 = 50$

02. Paper II

Part A – 20 Marks for each question – $20 \times 4 = 80$

Part B – 30 Marks for each question – $30 \times 4 = 120$

Total Marks for Paper II = 200

Final Marks – Paper I = 50

– Paper II – $\frac{200}{4}$ = 50

Final Marks = 100

Common Techniques of Marking Answer Scripts.

It is compulsory to adhere to the following standard method in marking answer scripts and entering marks into the mark sheets.

1. Use a red color ball point pen for marking. (Only Chief/Additional Chief Examiner may use a mauve color pen.)
2. Note down Examiner's Code Number and initials on the front page of each answer script.
3. Write off any numerals written wrong with a clear single line and authenticate the alterations with Examiner's initials.
4. Write down marks of each subsection in a \triangle and write the final marks of each question as a rational number in a \square with the question number. Use the column assigned for Examiners to write down marks.

Example: Question No. 03

| | | | |
|-------|-------|---|------------------------------|
| (i) | | ✓ | \triangle $\frac{4}{5}$ |
| | | | |
| | | | |
| (ii) | | ✓ | \triangle $\frac{3}{5}$ |
| | | | |
| | | | |
| (iii) | | ✓ | \triangle $\frac{3}{5}$ |
| | | | |
| | | | |

| | | | | | | | | | | |
|----|-----|---------------|---|------|---------------|---|-------|---------------|---|-----------------|
| 03 | (i) | $\frac{4}{5}$ | + | (ii) | $\frac{3}{5}$ | = | (iii) | $\frac{3}{5}$ | = | $\frac{10}{15}$ |
|----|-----|---------------|---|------|---------------|---|-------|---------------|---|-----------------|

MCQ answer scripts: (Template)

1. Marking templets for G.C.E.(A/L) and GIT examination will be provided by the Department of Examinations itself. Marking examiners bear the responsibility of using correctly prepared and certified templates.
2. Then, check the answer scripts carefully. If there are more than one or no answers Marked to a certain question write off the options with a line. Sometimes candidates may have erased an option marked previously and selected another option. In such occasions, if the erasure is not clear write off those options too.
3. Place the template on the answer script correctly. Mark the right answers with a '✓' and the wrong answers with a 'X' against the options column. Write down the number of correct answers inside the cage given under each column. Then, add those numbers and write the number of correct answers in the relevant cage.

Structured essay type and assay type answer scripts:

1. Cross off any pages left blank by candidates. Underline wrong or unsuitable answers. Show areas where marks can be offered with check marks.
2. Use the right margin of the overlaid paper to write down the marks.
3. Write down the marks given for each question against the question number in the relevant cage on the front page in two digits. Selection of questions should be in accordance with the instructions given in the question paper. Mark all answers and transfer the marks to the front page, and write off answers with lower marks if extra questions have been answered against instructions.
4. Add the total carefully and write in the relevant cage on the front page. Turn pages of answer script and add all the marks given for all answers again. Check whether that total tallies with the total marks written on the front page.

Preparation of Mark Sheets.

Except for the subjects with a single question paper, final marks of two papers will not be calculated within the evaluation board this time. Therefore, add separate mark sheets for each of the question paper. Write paper 01 marks in the paper 01 column of the mark sheet and write them in words too. Write paper II Marks in the paper II Column and right the relevant details. For the subject 51 Art, marks for Papers 01, 02 and 03 should be entered numerically in the mark sheets.

AL/2020/01/E-1(NEW)

සියලු ම හිමිකම් ඇවිරිණි / முழுப் பதிப்புரிமையுடையது / All Rights Reserved

නව නිර්දේශය/புதிய பாடத்திட்டம் / New Syllabus

NEW Department of Examinations, Sri Lanka

අධ්‍යයන පොදු සහතික පත්‍ර (උසස් පෙළ) විභාගය, 2020
 கல்விப் பொதுத் தராதரப் பத்திர (உயர் தர)ப் பரீட்சை, 2020
 General Certificate of Education (Adv. Level) Examination, 2020

භෞතික විද්‍යාව I
 பொளதிகவியல் I
 Physics I

01 E I

පැය දෙකයි
 இரண்டு மணித்தியாலம்
 Two hours

Instructions:

- * This question paper consists of 50 questions in 11 pages.
- * Answer **all** the questions.
- * Write your **Index Number** in the space provided in the answer sheet.
- * Read the instructions given on the back of the answer sheet carefully.
- * In each of the questions 1 to 50, pick one of the alternatives from (1), (2), (3), (4), (5) which is correct or most appropriate and mark your response on the answer sheet with a cross (x) in accordance with the instructions given on the back of the answer sheet.

Use of calculators is not allowed.
 (g = 10 m s⁻²)

1. Dimensions of Planck's constant are,
 (1) M²LT (2) M²LT⁻¹ (3) MLT² (4) MLT⁻¹ (5) ML²T⁻¹

2. Figure (a) shows the scale of a micrometer screw gauge when the spindle and the anvil touch each other. Figure (b) shows the scale when a metal sphere is properly placed between the spindle and the anvil. The pitch of the screw is 0.5 mm and the circular scale is divided into 50 equal divisions.

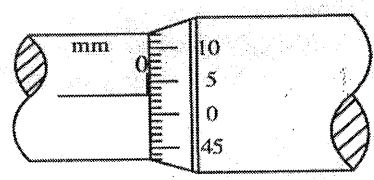

Figure(a)

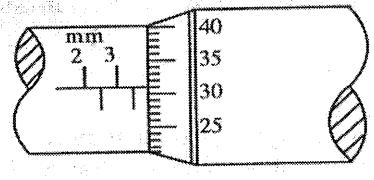

Figure(b)

What is the correct diameter of the metal sphere?
 (1) 3.28 mm (2) 3.31 mm (3) 3.78 mm (4) 3.81 mm (5) 3.84 mm

3. The threshold of hearing of a normal human ear is 10⁻¹² W m⁻². This corresponds to a sound intensity level of
 (1) 0 dB (2) 1 dB (3) 10 dB (4) 12 dB (5) 120 dB

4. The figure shows the velocity (v) - time (t) graph for an object moving along a straight line. What is the average velocity of the object from t = 0 to t = 4 s?

- (1) 1.5 m s⁻¹ (2) 2.0 m s⁻¹
- (3) 2.5 m s⁻¹ (4) 2.7 m s⁻¹
- (5) 3.3 m s⁻¹

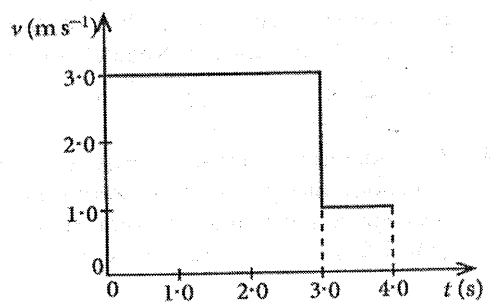

AL/2020/01/E-I(NEW)

- 2 -

5. The figure shows a thin uniform rod AB of length L and mass M . Moment of inertia of the rod about axis PQ parallel to the rod, situated at a distance y is,

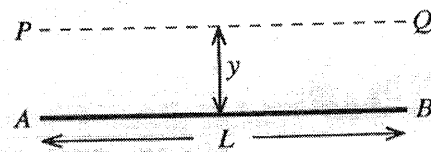

- (1) My^2
- (2) $M(L^2 + y^2)$
- (3) $\frac{1}{3}ML^2$
- (4) $\frac{1}{2}M(L^2 + y^2)$
- (5) zero

6. The quark content of a proton (p) and a neutron (n) are respectively given by,

- (1) ssd, sdd
- (2) udd, uus
- (3) ssd, uud
- (4) uud, udd
- (5) udd, uud

7. Which of the following statements made regarding seismic waves is **incorrect**?

- (1) All seismic waves are mechanical waves and require a medium to propagate.
- (2) Primary (P) waves are longitudinal and secondary (S) waves are transverse.
- (3) Speed of S-waves is less than that of P-waves.
- (4) S-waves can travel through both liquid and solid media.
- (5) P-waves can travel through both liquid and solid media.

8. A narrow beam of monochromatic light XY falls on a converging lens L as shown in the figure. After refraction through the lens, the beam hits the screen S and makes a light spot. What would be the position of the light spot?

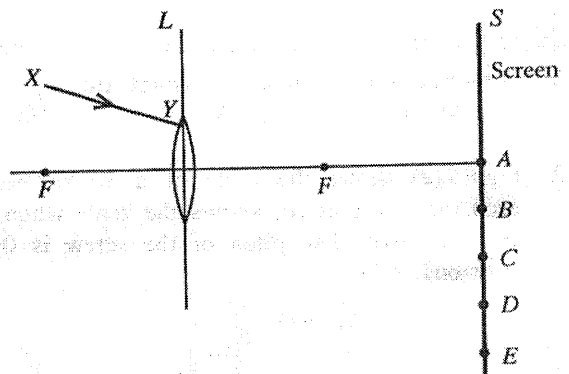

- (1) A
- (2) B
- (3) C
- (4) D
- (5) E

9. Positions of particles of a transverse wave travelling along $+x$ direction at a certain instance is shown in the figure. A pair of particles with same **instantaneous velocities** is,

- (1) B and F
- (2) A and D
- (3) B and C
- (4) C and F
- (5) B and E

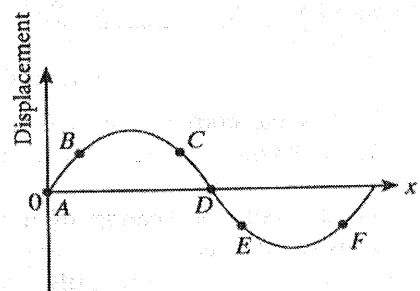

10. A small instrument of mass 1.0 kg is placed on a planet. The mass of the planet is three times and radius is two times that of the earth. What would be the weight of the instrument on the surface of the planet? Neglect all the other effects except gravitation.

- (1) $\frac{15}{4} \text{ N}$
- (2) $\frac{20}{3} \text{ N}$
- (3) $\frac{15}{2} \text{ N}$
- (4) 10 N
- (5) $\frac{45}{4} \text{ N}$

11. Two identical transverse waves of frequency 300 Hz and speed 30 m s^{-1} travelling in opposite directions along x -axis, superimpose with each other and produce a standing wave. The distance between a node and its adjacent anti-node is equal to,

- (1) 2.5 cm
- (2) 5.0 cm
- (3) 10.0 cm
- (4) 15.0 cm
- (5) 20.0 cm

AL/2020/01/E-I(NEW)

- 3 -

12. Very long eight parallel wires each carries a current of 10 A. The directions of the current in each wire are shown in the figure. The magnitude and the direction of the magnetic flux density produced at the centre (C) are,

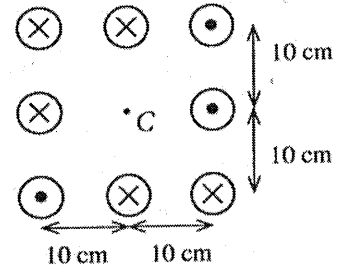

($\frac{\mu_0}{4\pi} = 10^{-7} \text{ T m A}^{-1}$; Neglect the effect of earth's magnetic field)

- (1) $20 \mu\text{T} \downarrow$ (2) $20 \mu\text{T} \uparrow$
 (3) $40 \mu\text{T} \uparrow$ (4) $40 \mu\text{T} \downarrow$
 (5) $40 \mu\text{T} \rightarrow$
13. Two adjacent rooms A and B at same temperature, connected by a closed door are initially at relative humidity (RH) 60% and 90% respectively. The volume of room A is twice that of room B. If the door is kept open for a long time at the same temperature, what would be the final relative humidity of the rooms?
- (1) 65% (2) 70% (3) 75% (4) 80% (5) 85%

14. All batteries shown in the circuit diagram have negligible internal resistances. If the capacitor C is ideal, what is the potential difference across C?

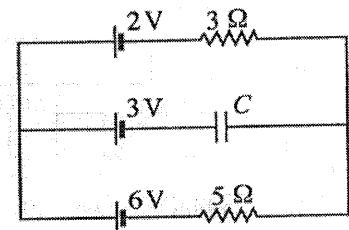

- (1) 0.5 V (2) 1.0 V
 (3) 2.0 V (4) 2.5 V
 (5) 3.5 V
15. Which of the following statement is **incorrect**?
- (1) The electrical conductivity of an intrinsic semiconductor increases with increasing temperature.
 (2) A full-wave rectifier cannot produce a constant d.c. output voltage for a sinusoidal input.
 (3) In a bipolar transistor, the emitter is heavily doped than that of the collector.
 (4) Drain current (I_D) of a Junction Field Effect Transistor (JFET) is maximum when Gate to Source voltage is zero ($V_{GS} = 0$).
 (5) When an op-amp is used as a voltage comparator, closed loop state is used.
16. A particle of mass m performs a simple harmonic motion. If the maximum velocity and the maximum acceleration of the particle are V and a respectively, the angular frequency (ω) of the particle is given by,
- (1) $\frac{V}{ma}$ (2) $\frac{2\pi V}{a}$ (3) $\frac{2\pi a}{V}$ (4) $\frac{a}{V}$ (5) $\frac{V}{a}$

17. The length of the potentiometer wire AB is 600 cm and its resistance is 10Ω . R is a resistance box. When R is set to 70Ω the balance length is 280 cm. What will be the distance that sliding key J must be moved from the previous position to balance again if R is changed to 80Ω ?

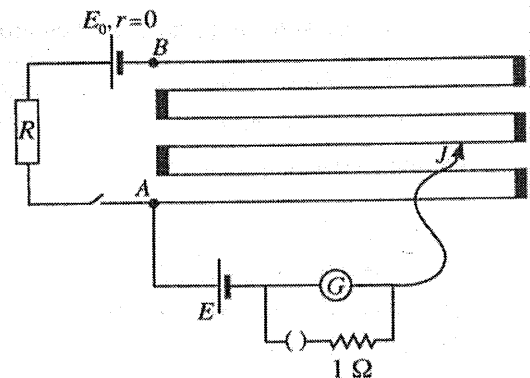

- (1) 45 cm (2) 40 cm
 (3) 35 cm (4) 30 cm
 (5) 25 cm

AL/2020/01/E-I(NEW)

- 4 -

18. Logical inputs A, B and C of the given circuit is shown below.

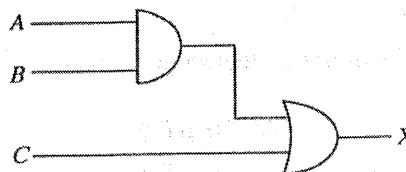
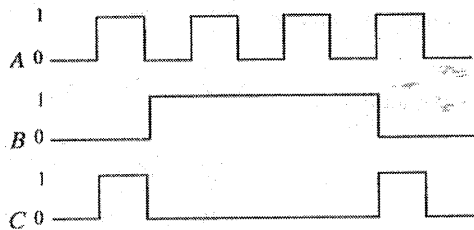

The shape of the correct output (X) is,

- (1)
- (2)
- (3)
- (4)
- (5)

19. The combined object, illustrated in the figure is formed by joining four metallic rings A, B, C and D of radii $r, 2r, 2r$ and $3r$ respectively made out of same uniform wire. The distance to the centre of gravity of the combined object from point X is,

- (1) r
- (2) $\frac{5r}{4}$
- (3) $2r$
- (4) $\frac{5r}{2}$
- (5) zero

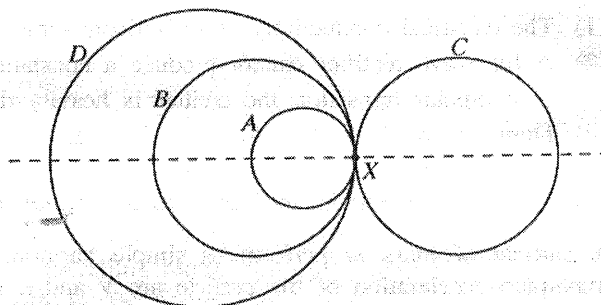

20. Water and coconut oil are poured into the two limbs of a U-tube as shown in the figure. Assume that the water-oil interface is at the middle of the tube and it is vertical. (ρ_w = density of water, ρ_o = density of coconut oil) Consider the following expressions about this situation.

- (A) Pressure at point P = Pressure at point Q
- (B) $h_1 \rho_w = h_2 \rho_o$
- (C) $h_3 \rho_w = h_4 \rho_o$

Of the above expressions,

- (1) only (A) is true.
- (2) only (B) is true.
- (3) only (A) and (B) are true.
- (4) only (B) and (C) are true.
- (5) all (A), (B) and (C) are true.

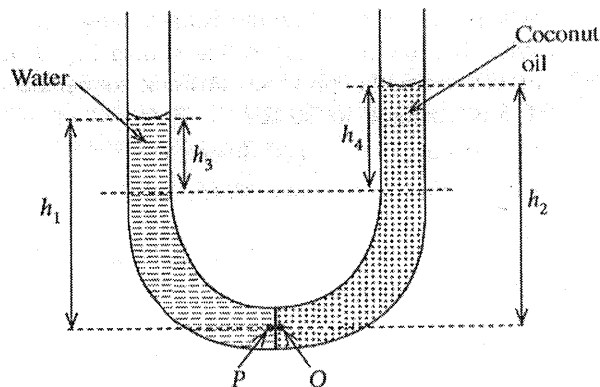

AL/2020/01/E-I(NEW)

- 5 -

21. Two identical opened pipes each of length 50 cm are sounded with their fundamental notes at 15 °C. The variation of velocity of sound v (m s^{-1}) in air with temperature is given by $v = 331 + 0.6\theta$, where θ is in °C. If the temperature of one pipe is raised to 30 °C, what would be the number of beats produced per second?

- (1) 4 (2) 6 (3) 9 (4) 12 (5) 14

22. Two blocks A and B of mass 0.5 kg and 1.0 kg respectively are connected by a massless inextensible string which goes over a massless, smooth pulley as shown in the figure. The coefficient of dynamic friction between all contact surfaces is 0.25. What is the force F needed to drag the block B to the left with a constant speed?

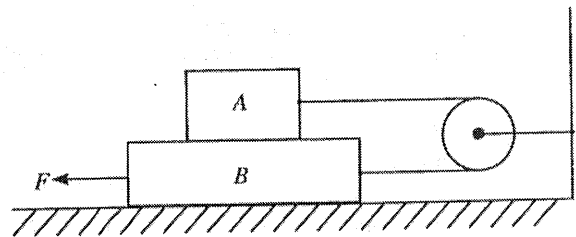

- (1) 2.50 N (2) 3.75 N (3) 5.00 N (4) 6.25 N (5) 7.50 N

23. A projectile suddenly explodes into two fragments with equal masses at the highest point (P) of its trajectory. If one fragment falls vertically downwards with an initial velocity as shown, which of the following diagrams best represents the path of the other fragment?

(Neglect air resistance. The broken line represents the path of the projectile if there was no explosion.)

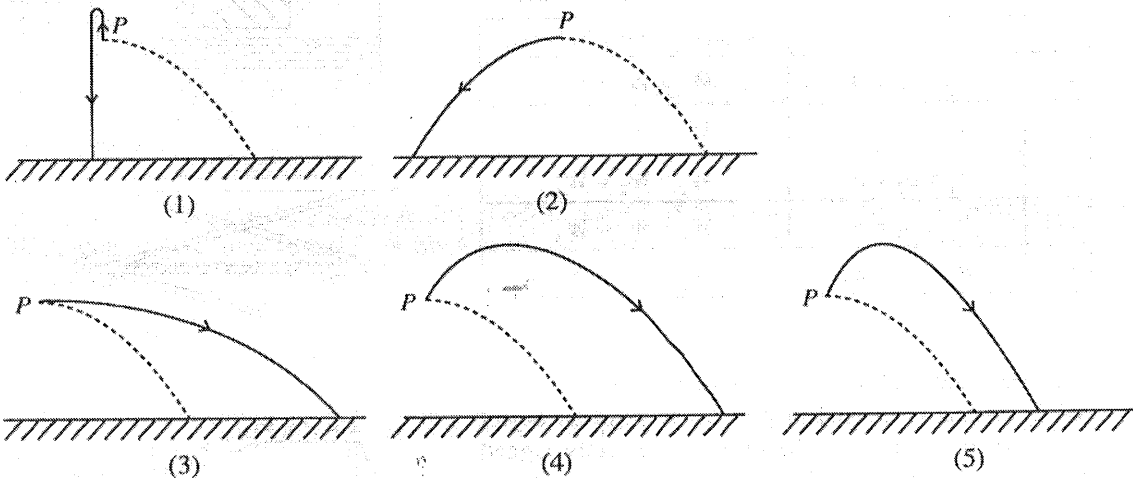
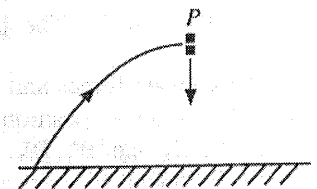

24. Two thermodynamic processes ($a \rightarrow b \rightarrow c$ and $a \rightarrow c$) of a closed system of an ideal gas are shown in the figure. In the process abc , 6.0 kJ heat is absorbed by the system to go from a to b and 1.8 kJ heat is absorbed from b to c . What is the change in internal energy in the process ac ?

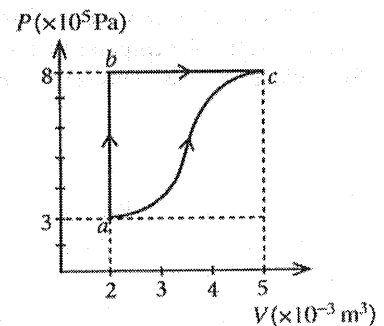

- (1) 4.2 kJ (2) 5.4 kJ
 (3) 6.3 kJ (4) 6.7 kJ
 (5) 10.2 kJ

AL/2020/01/E-I(NEW)

- 6 -

25. Three point charges $+4q$, $+3q$ and $-q$ are placed at vertices of an equilateral triangle of side a as shown in the figure. The electric potential energy of the system is given by,

- (1) $\frac{5q^2}{4\pi\epsilon_0 a}$ (2) $\frac{3q^2}{2\pi\epsilon_0 a}$
 (3) $\frac{7q^2}{4\pi\epsilon_0 a}$ (4) $\frac{2q^2}{\pi\epsilon_0 a}$
 (5) $\frac{19q^2}{4\pi\epsilon_0 a}$

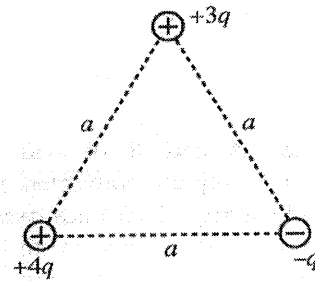

26. A copper block is hung over a beaker of water by a spring balance as shown in the figure. Consider the following positions while the beaker of water is slowly raising upward.

- Position 1 : The block is partially submerged.
 Position 2 : The block is completely submerged.
 Position 3 : The block is on the bottom surface of the beaker.

The buoyant forces and the readings of the balance with respect to positions 1, 2 and 3 are given by B_1, B_2, B_3 and W_1, W_2, W_3 respectively. Which of the following is correct?

| | Buoyant Force | Reading of the balance |
|-----|-------------------|------------------------|
| (1) | $B_1 < B_2 < B_3$ | $W_1 > W_2 > W_3$ |
| (2) | $B_1 = B_2 < B_3$ | $W_1 = W_2 > W_3$ |
| (3) | $B_1 = B_2 < B_3$ | $W_1 > W_2 = W_3$ |
| (4) | $B_1 < B_2 = B_3$ | $W_1 > W_2 = W_3$ |
| (5) | $B_1 < B_2 = B_3$ | $W_1 > W_2 > W_3$ |

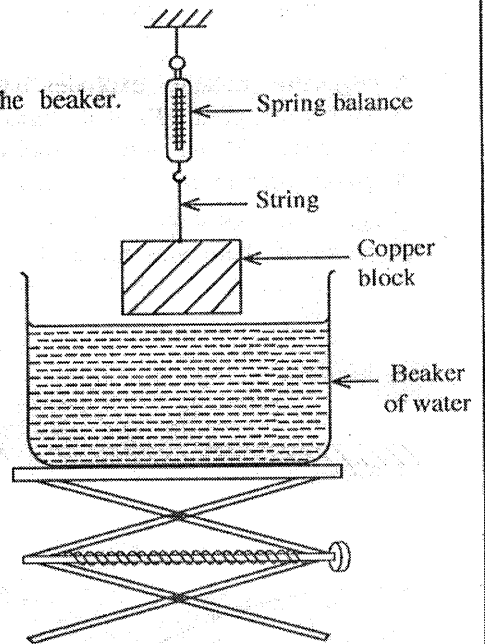

27. The cross-sectional area of a uniform cylindrical metal rod is gradually reduced in part BC to form an object as shown in the figure. The object is perfectly lagged and the two ends of the object are maintained at temperature of 100°C and 20°C . At the steady state, the variation of temperature (θ) along the axis (l) of the object is best represented by,

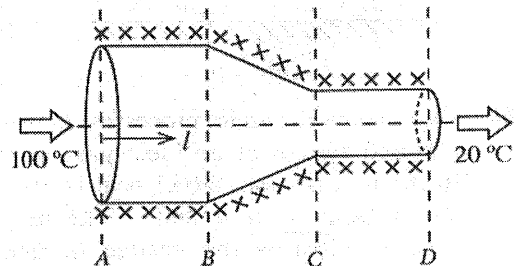

- (1) (2) (3) (4) (5)

AL/2020/01/E-I(NEW)

- 7 -

28. Three small conducting spheres carrying charges $+Q$, $-Q$ and $+Q$ are located at the vertices of an equilateral triangle ABC situated on a frictionless horizontal surface as shown in the figure. Spheres at B and C are fixed and the sphere at A is free to move. The possible path of the sphere at A is best represented by

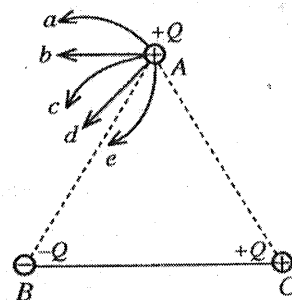

- (1) a (2) b
- (3) c (4) d
- (5) e

29. As shown in the figure a conducting loop is placed perpendicular to a uniformly increasing magnetic field. Which of the following graphs best represents the variation of the magnitude of induced e.m.f. (E) in the loop with the rate of change of the magnetic flux density (R)?

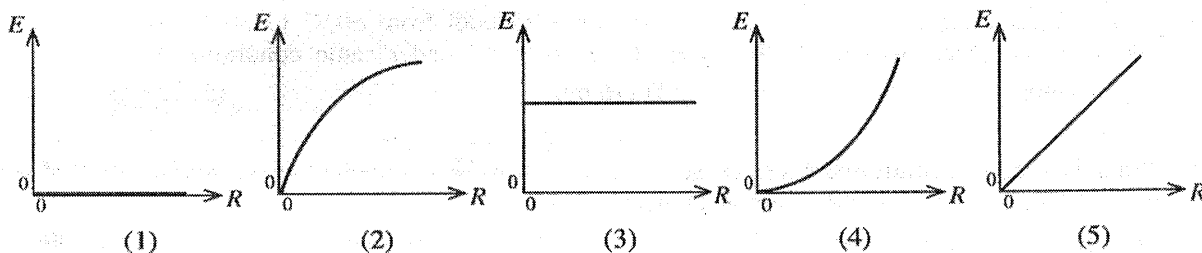
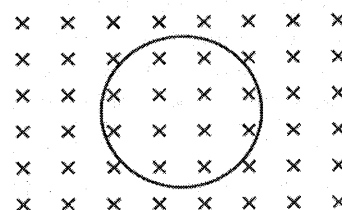

30. An object of mass m stationary at time $t=0$ is subjected to a force F , directed along a straight line, that varies with time t as shown in the graph. Select the correct statement from the followings.

After the motion has started, the velocity of the object becomes zero,

- (1) at $t=40$ s only.
- (2) at $t=70$ s only.
- (3) at $t=40$ s and $t=100$ s.
- (4) at $t=70$ s and $t=120$ s.
- (5) during the time interval from $t=60$ s to $t=80$ s.

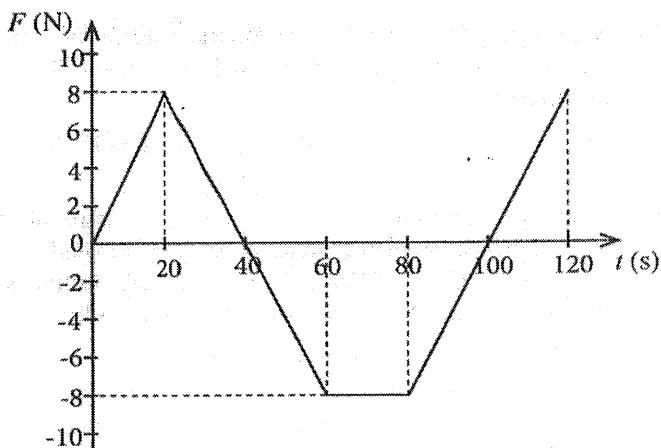

31. Identical small spherical droplets of mercury are charged so that each droplet has the same electric potential of 0.01 V. If one million (10^6) such droplets are combined to form a large spherical drop, what would be the electric potential of the large drop?

- (1) 0.01 V (2) 1.0 V (3) 10 V (4) 100 V (5) 1000 V

AL/2020/01/E-I(NEW)

- 8 -

32. A narrow beam of monochromatic light is passing through a prism placed in air. Consider the following statements about the angle of **minimum deviation** D .

- (A) D increases with the increase of refractive index of the material of prism.
- (B) D first decreases and then increases with gradual increasing of the angle of incidence.
- (C) D increases with the increase of the angle of prism.

Of the above statements,

- (1) only (A) is true.
- (2) only (A) and (B) are true.
- (3) only (A) and (C) are true.
- (4) only (B) and (C) are true.
- (5) all (A), (B) and (C) are true.

33. Using a two-way key K , a cell of e.m.f. E and internal resistance r can be connected in series either with resistor of resistance $8\ \Omega$ or $2\ \Omega$ as shown in the figure. If power dissipation of each resistor is the same, what would be the value of the internal resistance r ?

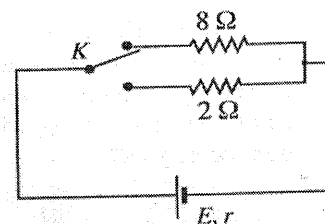

- (1) $2\ \Omega$
- (2) $4\ \Omega$
- (3) $5\ \Omega$
- (4) $6\ \Omega$
- (5) $8\ \Omega$

34. A hot object hung in a room at 30°C takes 5 min to cool from 60°C to 50°C . What is the time taken by the object to cool further from 44°C to 36°C under same conditions?

- (1) 10 min
- (2) 12.5 min
- (3) 15 min
- (4) 20 min
- (5) 25 min

35. What is the **maximum** mass of ice at -5°C that can be completely dissolved in 1 kg of water at 35°C in a container with negligible heat capacity?

Let the specific heat capacities of ice and water be $2.0 \times 10^3\ \text{J kg}^{-1}\ ^\circ\text{C}^{-1}$ and $4.0 \times 10^3\ \text{J kg}^{-1}\ ^\circ\text{C}^{-1}$ respectively, and the specific latent heat of fusion of ice be $3.4 \times 10^5\ \text{J kg}^{-1}$. Assume there is no exchange of heat with the surrounding.

- (1) 200 g
- (2) 240 g
- (3) 300 g
- (4) 360 g
- (5) 400 g

36. Magnifying power of a compound microscope in normal adjustment is 100. The focal length of the objective lens is 2.5 cm and the object distance is 2.6 cm. What is the magnification of the eyepiece?

- (1) 4
- (2) 5
- (3) 10
- (4) 20
- (5) 25

37. A charged particle moving in a circular path of radius r perpendicular to a uniform magnetic field penetrates through a thin aluminium sheet as shown in the figure. If half of the initial kinetic energy is lost due to penetration, what would be the radius of the new path of the particle?

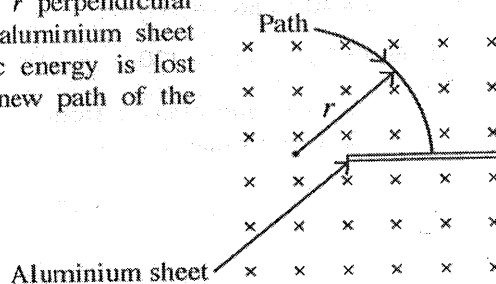

- (1) $\frac{r}{2}$
- (2) $\frac{r}{\sqrt{2}}$
- (3) r
- (4) $\sqrt{2}r$
- (5) $2r$

AL/2020/01/E-I(NEW)

- 9 -

38. The electrical circuit shown in the figure has ideal centre-zero voltmeter and ammeter. The 20 V battery has negligible internal resistance. The value of the variable resistor R can be changed from 0 to 100Ω . What are the ammeter (A) and voltmeter (V) readings when the sliding key K is at X and at Y ?

| | K is at X | | K is at Y | |
|-----|---------------|-------|---------------|-------|
| | (A) | (V) | (A) | (V) |
| (1) | 200 mA | 0 | 200 mA | +20 V |
| (2) | 400 mA | 0 | 400 mA | +20 V |
| (3) | 200 mA | -12 V | 200 mA | +8 V |
| (4) | 400 mA | +12 V | 400 mA | -8 V |
| (5) | 400 mA | -12 V | 400 mA | +8 V |

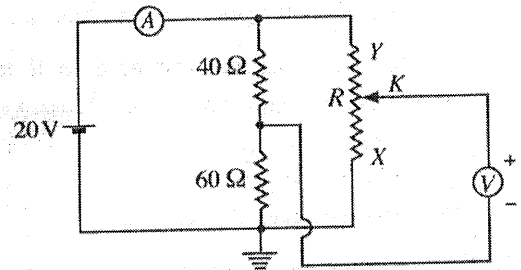

39. A metal wire of length 2 m and cross-sectional area 5 mm^2 is rigidly clamped at two points A and B which are 2 m apart in the same horizontal plane. Then a block of mass 2.4 kg is hung from the mid point of the wire as shown in the figure. The mid point of the wire sags 2.0 cm from the initial position and the total extension of the wire is 0.04 cm. What will be the approximate value of Young's modulus of the metal?

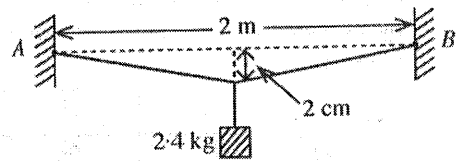

- (1) $2 \times 10^{11} \text{ N m}^{-2}$ (2) $3 \times 10^{11} \text{ N m}^{-2}$ (3) $4 \times 10^{11} \text{ N m}^{-2}$
 (4) $6 \times 10^{11} \text{ N m}^{-2}$ (5) $12 \times 10^{11} \text{ N m}^{-2}$

40. An infinitely long thin straight wire which is located on the z -axis has a linear charge density of $-\lambda$. A small positive charge $+q$ of mass m is allowed to move in the xy -plane in a circular path of radius r about the wire. The periodic time of the charge is given by,

- (1) $\sqrt{\frac{8\pi^3 r^2 m \epsilon_0}{\lambda q}}$ (2) $\sqrt{\frac{4\pi^2 r^3 m \epsilon_0}{\lambda q}}$ (3) $\sqrt{\frac{\lambda q}{8\pi^3 r^2 m \epsilon_0}}$ (4) $\sqrt{\frac{\lambda q}{4\pi^2 r^3 m \epsilon_0}}$ (5) $\sqrt{\frac{8r^2 m \lambda}{\epsilon_0 q}}$

41. As shown in the figure a horizontal pipe ABC is connected to a water tank with a large cross-sectional area of the pipe at B is twice that of at C . Initially a water tap (T) located at D is closed. Once the tap is opened what would be the height of water level in the vertical tube located at B ? (Assume that the water flow is steady and streamline; Neglect the viscosity of water.)

- (1) $\frac{1}{4} h$ (2) $\frac{1}{2} h$
 (3) $\frac{3}{4} h$ (4) h
 (5) $\frac{4}{3} h$

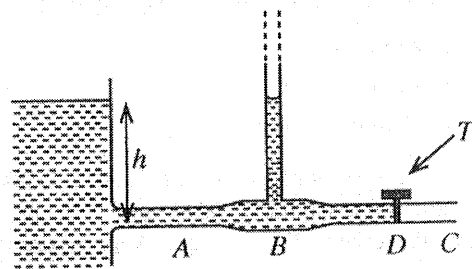

42. A parachutist bails out from a helicopter at time $t=0$. After a certain time he opens his parachute and then reaches the ground. Which of the following graph best represents the variation of the vertical component of the velocity (v) of the parachutist with time (t)?

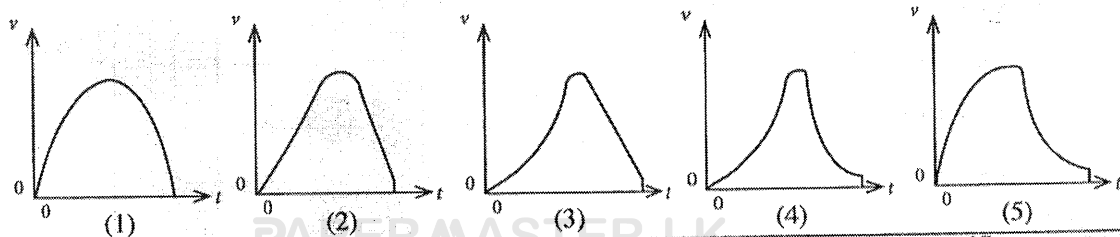

43. Consider the following statements about the half-life ($T_{1/2}$) of radioactive atoms in a sample.

- (A) $T_{1/2}$ changes with the number of radioactive atoms present in the sample
- (B) $T_{1/2}$ changes with the date and time of the prepared sample.
- (C) $T_{1/2}$ does not change even if the radioactive atoms are ionized.

Of the above statements,

- (1) only (A) is true.
- (2) only (B) is true.
- (3) only (C) is true.
- (4) only (A) and (B) are true.
- (5) only (B) and (C) are true.

44. An electron moves in the plane of the paper through two regions along the path shown in the figure by broken line. Uniform Magnetic fields B_1 and B_2 exist in regions I and II respectively. A uniform electric field exists only in region I directed into the plane of the paper as denoted by crosses (\times). Which of the following gives the correct directions of magnetic fields in regions I and II?

| | B_1 | B_2 |
|-----|-------|-------|
| (1) | ↑ | ⊗ |
| (2) | ↑ | ⊙ |
| (3) | ⊙ | ⊗ |
| (4) | ⊗ | ⊙ |
| (5) | ↓ | ⊙ |

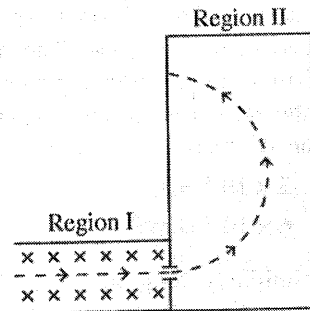

45. Figure shows a capillary tube dipped vertically in a container of water with a large cross-sectional area. The system is fixed in an elevator at rest. The open end of the capillary is 40 mm above the water level of the container and the capillary rise is 8 mm.

If the elevator is,

- (I) moving downwards with an acceleration of 5 m s^{-2}
- (II) falling freely

what would be the respective capillary rise?

- (1) 4 mm, 0
- (2) 16 mm, 0
- (3) 4 mm, 8 mm
- (4) 16 mm, 32 mm
- (5) 16 mm, 40 mm

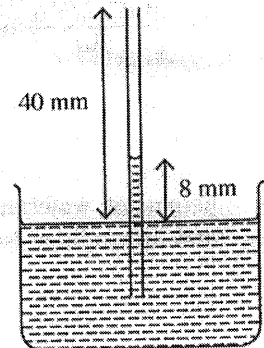

46. Two vertical glass tubes (T_1 and T_2) filled with a liquid are connected at their lower ends by a horizontal capillary tube. One tube (T_1) is surrounded by a mixture of ice and water at 0°C , and the other (T_2) by water kept at constant temperature 40°C . The difference in the heights of the liquid in the two columns is 1.6 cm and the height of the liquid column at 0°C is 80 cm as shown in the figure (drawn not to a scale). The real volume expansivity of the liquid is,

- (1) $2.5 \times 10^{-4} \text{ }^\circ\text{C}^{-1}$
- (2) $5.0 \times 10^{-4} \text{ }^\circ\text{C}^{-1}$
- (3) $6.0 \times 10^{-4} \text{ }^\circ\text{C}^{-1}$
- (4) $1.0 \times 10^{-3} \text{ }^\circ\text{C}^{-1}$
- (5) $1.2 \times 10^{-3} \text{ }^\circ\text{C}^{-1}$

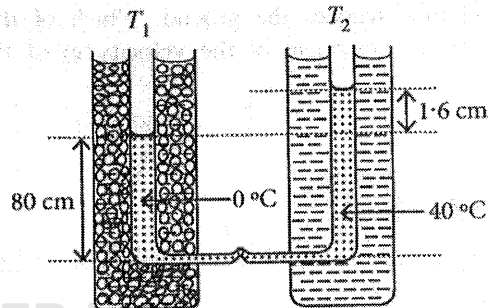

47. Figure shows an infinite ladder network of $1\ \Omega$ resistors. If the equivalent resistance of this network between points A and B is R , which of the following is true?

- (1) $R < 2\ \Omega$
- (2) $R = 2\ \Omega$
- (3) $R > 3\ \Omega$
- (4) $R = 3\ \Omega$
- (5) $2\ \Omega < R < 3\ \Omega$

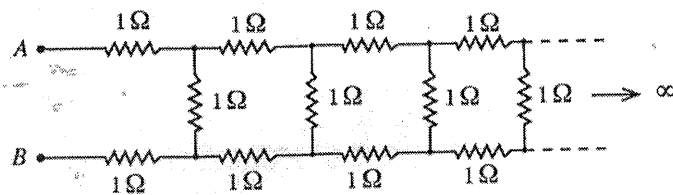

48. Three stars each of mass m are at the vertices of an equilateral triangle of side a as shown in the figure. Suppose, these three stars rotate in a circular path about the centroid of the triangle while retaining the initial distances among the stars. If only the mutual gravitational forces are acting among the stars, the periodic time of the system is given by,

- (1) $2\pi\sqrt{\frac{a^3}{2GM}}$
- (2) $2\pi\sqrt{\frac{a^3}{3GM}}$
- (3) $2\pi\sqrt{\frac{3a^3}{GM}}$
- (4) $2\pi\sqrt{\frac{2a^3}{GM}}$
- (5) $2\pi\sqrt{\frac{3a^3}{2GM}}$

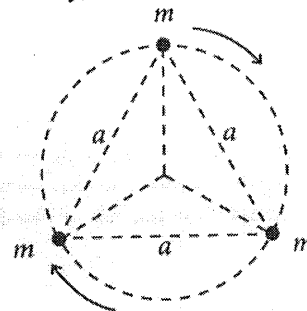

49. Block A of mass 2 kg and block B of mass 6 kg are placed on a frictionless horizontal surface. Two identical springs of negligible mass are fixed to the blocks as shown in the figure. Block A is projected with speed 2 m s^{-1} towards block B which is at rest. What is the maximum energy that the two springs could attain?

- (1) 0
- (2) 1 J
- (3) 2 J
- (4) 3 J
- (5) 4 J

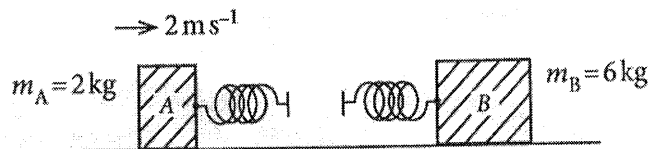

50. Five thin flat metal plates, each of area A are kept parallelly in vacuum with an equal gap d . If plate P is connected to S and plate R is connected to T using conducting wires as shown in the figure, the equivalent capacitance between terminals X and Y is given by,

- (1) $\frac{2\epsilon_0 A}{d}$
- (2) $\frac{5\epsilon_0 A}{3d}$
- (3) $\frac{4\epsilon_0 A}{5d}$
- (4) $\frac{\epsilon_0 A}{2d}$
- (5) $\frac{\epsilon_0 A}{5d}$

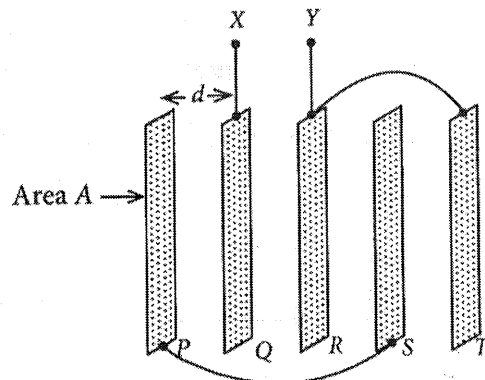

* * *

AL/2020/01/E-I(OLD)

සියලු ම හිමිකම් ඇවිරිණි / முழுப் பதிப்புரிமையுடையது / All Rights Reserved

පැරණි නිර්දේශය ප්‍රමාණය පාලන ක්‍රමලේඛය / Old Syllabus

OLD
 இலங்கைப் பரீட்சைத் திணைக்களம் இலங்கைப் பரீட்சைத் திணைக்களம் இலங்கைப் பரීட்சைத் திணைக்களம் இலங்கைப் பரීட்சைத் திணைக்களம் இலங்கைப் பரීட்சைத் திணைக்களம்
 Department of Examinations, Sri Lanka
 இலங்கைப் பரීட்சைத் திணைக்களம் இலங்கைப் பரීட்சைத் திணைக்களம் இலங்கைப் பரීட்சைத் திணைக்களம் இலங்கைப் பரීட்சைத் திணைக்களம் இலங்கைப் பரීட்சைத் திணைக்களம்
 Department of Examinations, Sri Lanka
 இலங்கைப் பரීட்சைத் திணைக்களம் இலங்கைப் பரීட்சைத் திணைக்களம் இலங்கைப் பரීட்சைத் திணைக்களம் இலங்கைப் பரීட்சைத் திணைக்களம் இலங்கைப் பரීட்சைத் திணைக்களம்
 Department of Examinations, Sri Lanka

අධ්‍යයන පොදු කෘතීම පත්‍ර (උසස් පෙළ) විභාගය, 2020
 கல்விப் பொதுத் தராதரப் பத்திர (உயர் தர)ப் பரீட்சை, 2020
 General Certificate of Education (Adv. Level) Examination, 2020

භෞතික විද්‍යාව I
 பொளதிகவியல் I
 Physics I

01 E I

පැය දෙකයි
 இரண்டு மணித்தியாலம்
 Two hours

Instructions:

- * This question paper consists of 50 questions in 11 pages.
 - * Answer all the questions.
 - * Write your Index Number in the space provided in the answer sheet.
 - * Read the instructions given on the back of the answer sheet carefully.
 - * In each of the questions 1 to 50, pick one of the alternatives from (1), (2), (3), (4), (5) which is correct or most appropriate and mark your response on the answer sheet with a cross (x) in accordance with the instructions given on the back of the answer sheet.
- Use of calculators is not allowed.
 (g = 10 m s⁻²)

All the Other Questions are same as for NEW syllabus Except for the following questions :

6. An electric lamp emits 10²⁰ photons per second of wavelength 620 nm. What is the power of the lamp?
 (hc = 1240 eV nm; 1 eV = 1.6 × 10⁻¹⁹ J)
- (1) 100 W (2) 96 W (3) 64 W (4) 32 W (5) 30 W

ශ්‍රී ලංකා විභාග දෙපාර්තමේන්තුව
 இலங்கைப் பரீட்சைத் திணைக்களம்
 අ.පො.ස. (උ.පෙළ) / ක.පො.ත. (උපරි තර) ප්‍රවීණතා- 2020
 නව / පැරණි නිර්දේශය/ புதிய / பழைய பாடத்திட்டம்

විෂය අංකය

01

பாட இலக்கம்

විෂය

Physics

பாடம்

ලකුණු දීමේ පටිපාටිය / புள்ளிவழங்கும் திட்டம்

I පත්‍රය / பத்திரம் I

| ප්‍රශ්න අංකය විනා இல. | පිළිතුරු අංකය விடை இல. | ප්‍රශ්න අංකය විනා இல. | පිළිතුරු අංකය விடை இல. | ප්‍රශ්න අංකය විනා இல. | පිළිතුරු අංකය விடை இல. | ප්‍රශ්න අංකය විනා இல. | පිළිතුරු අංකය விடை இல. | ප්‍රශ්න අංකය විනා இல. | පිළිතුරු අංකය விடை இல. |
|-----------------------------|---------------------------------|-----------------------------|---------------------------------|-----------------------------|---------------------------------|-----------------------------|---------------------------------|-----------------------------|---------------------------------|
| 01. | 5 | 11. | 1 | 21. | 3 | 31. | 4 | 41. | 3 |
| 02. | 3 | 12. | 4 | 22. | 4 | 32. | 3 | 42. | 5 |
| 03. | 1 | 13. | 2 | 23. | 4 | 33. | 2 | 43. | 3 |
| 04. | 3 | 14. | 1 | 24. | All | 34. | 1 | 44. | 2 |
| 05. | 1 | 15. | 5 | 25. | 1 | 35. | 5 | 45. | 5 |
| 06. | 4 | 16. | 4 | 26. | 5 | 36. | 1 | 46. | 2 |
| 07. | 4 | 17. | 3 | 27. | 4 | 37. | 2 | 47. | 5 |
| 08. | 4 | 18. | 2 | 28. | 3 | 38. | 5 | 48. | 2 |
| 09. | 1 | 19. | 2 | 29. | 5 | 39. | 4 | 49. | 4 |
| 10. | 3 | 20. | 3 | 30. | 2 | 40. | 1 | 50. | 2 |

❖ විශේෂ උපදෙස්/விசேட அறிவுறுத்தல் :

එක් පිළිතුරකට/ஒரு சரியான விடைக்கு ලකුණු 01 බැගින්/புள்ளி வீதம்

මුළු ලකුණු/மொத்தப் புள்ளிகள் 1× 50= 50

PAPERMASTER.LK

PART A – Structured Essay

Answer all four questions on this paper itself.

$(g = 10 \text{ m s}^{-2})$

1. You are asked to determine the spring constant (k) of a helical spring by plotting a graph of extension against load. In the experimental setup shown in the figure, one end of the spring is attached to a scale pan and the other end is firmly connected to a stand. Assume that the masses of the scale pan and the spring are negligible.

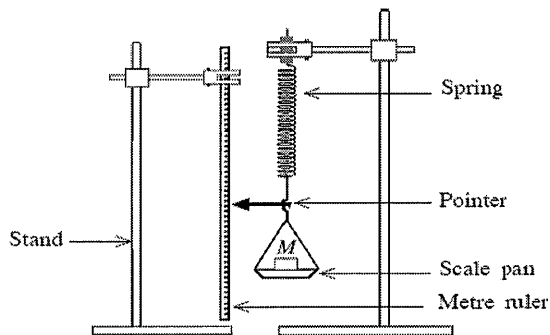

- (a) When a force F is applied to the spring, the length of the spring is increased by an amount x . Write down an expression for F in terms of k and x .

$F = kx$ (or $-kx$)

(02)

- (b) (i) The table below gives the values of mass (M) placed on the pan and the corresponding readings of the pointer. Complete the extension column in the table.

| Mass on the scale pan, M (gram) | Reading of the pointer (cm) | Extension x of the spring (cm) |
|-----------------------------------|-----------------------------|----------------------------------|
| 0 | 1.0 | 0 |
| 50 | 2.0 | 1.0 |
| 100 | 3.0 | 2.0 |
| 150 | 4.0 | 3.0 |
| 200 | 5.2 | 4.2 |
| 250 | 6.0 | 5.0 |
| 300 | 6.8 | 5.8 |

All entries correct (02)

(At least three entries correct 01 mark)

(ii) Plot a graph of extension x (cm) against mass on the scale pan M (gram) on the following grid.

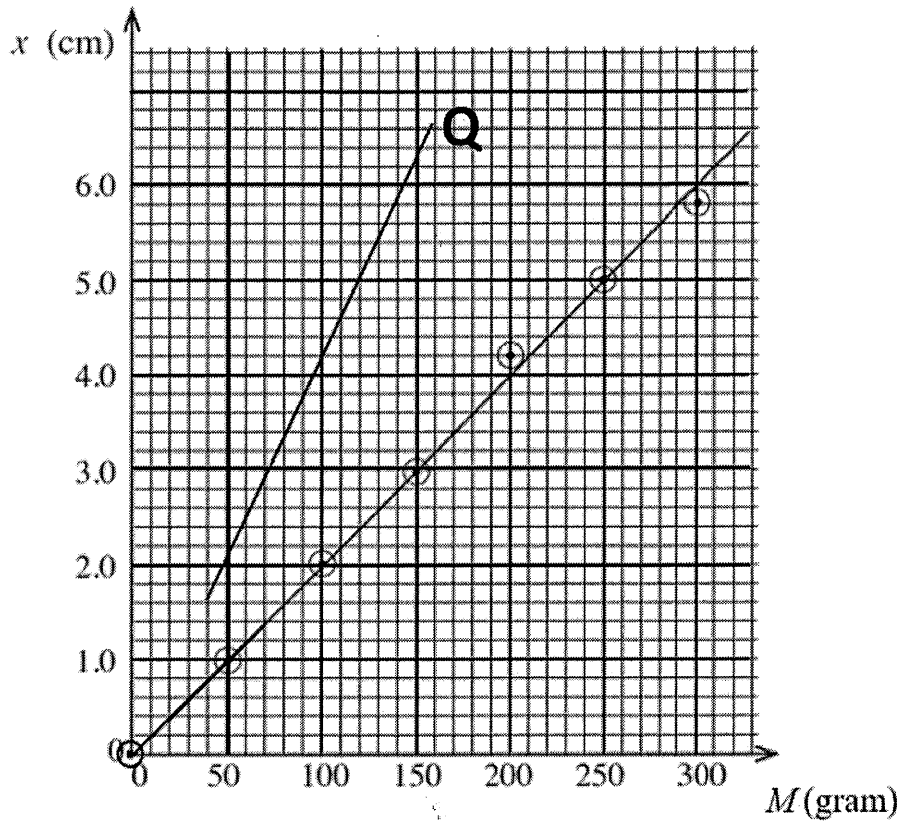

Selecting the proper scale for M (01)

(No other selections are accepted)

Selecting the proper scale for x (01)

(No other selections are accepted)

Marking of **at least five points** correctly on the grid.....(02)

[Points should be marked by dots (with or without circles) OR crosses]

(At least three points are correctly marked - 01 mark)

For drawing the straight line graph as shown.....(01)

(No other lines are accepted)

(iii) Using the graph drawn above determine the value of k in SI units.

$$\text{Gradient} = \frac{6.0-0.8}{300-40} = \frac{5.2}{260} \dots\dots\dots (02)$$

(Students can select any two points lying on the graph to determine the gradient; disregard the units of the numerator and the denominator)

$$= 0.02 \text{ cm gram}^{-1}$$

$$\text{Identifying } k = \frac{g}{\text{gradient}} \text{ OR } \frac{1}{0.02} \left[\text{OR } \frac{1}{\text{gradient}} \right] \dots\dots\dots(01)$$

$$k = 50 \text{ N m}^{-1} \text{ (OR } 50 \text{ kg s}^{-2}\text{)} \dots\dots\dots (02)$$

(For correct value and the correct unit)

[Value correct, unit incorrect – 01 mark]

(c) Write down two essential experimental steps that you have to follow when taking readings.

- (1) Loading of masses must be done gently OR readings should be noted only when the pointer comes to rest/equilibrium.
- (2) The masses should be placed at the center of the pan.
- (3) Pointer should not touch the metre ruler OR the pointer should move above/over the ruler
OR pointer should not be far away/should be close to the metre ruler.
- (4) Record the corresponding readings of the pointer while loading and unloading (and take their average)
- (5) Look straight through the pointer when taking readings OR take readings without parallax errors.
- (6) The extension of the spring should not exceed the proportional limit..... (02)

(Any two correct steps)
(Any one correct step – 01 mark)

(d) To maintain the percentage error of k within 5% what should be the maximum error (Δk) of the value of k ?

$$\frac{\Delta k}{50} \times 100 = 5 \dots\dots\dots (01)$$

(for the correct expression or substitution)

$$\Delta k = 2.5 \text{ N m}^{-1} \dots\dots\dots (01)$$

[When awarding this mark, disregard the unit]

(c) Another spring of negligible mass is connected in series with the above spring and the experiment is repeated with the same masses. Draw the expected graph in this situation on the same grid in (b) (ii) above, and label it as Q .

(Extensions will be increased for the same mass. Therefore, the effective spring constant would be reduced.)

Straight line with a higher gradient/above the line drawn earlier

(01)

Line with no intercept/going through the origin (OR seem to go through the origin).....

(01)

[Drawing a parallel line to the line drawn earlier – NO marks; Drawing a line below the line drawn earlier – NO marks]

2. You are asked to determine the atmospheric pressure using a dry air column trapped in a quill tube of length L . The figure shown is incomplete and not drawn to scale.

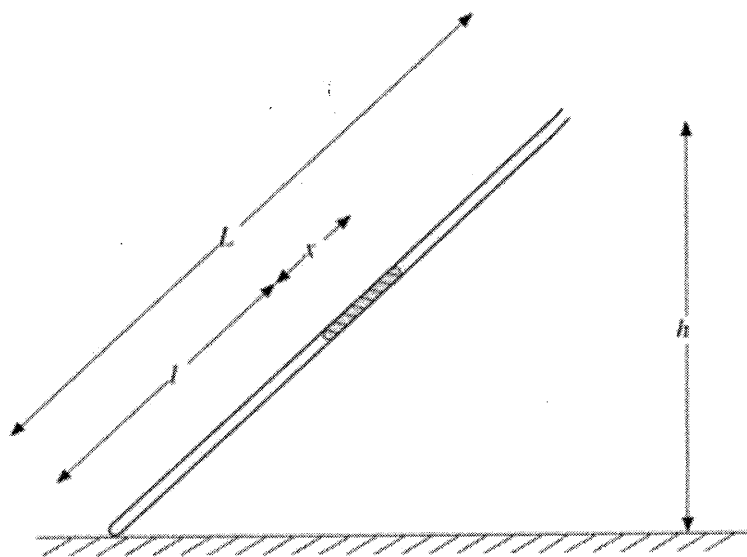

(a) Complete the experimental set up by drawing appropriate items and name them.

Metre ruler (or two rulers) and a (clamp) stand.(02)

[Drawing (and naming) the ruler -01 mark; Drawing (and naming) the stand -01 mark]

The ruler (or scale) must be along the quill tube and must touch the tube, (with zero mark of the ruler at the lower end of the tube).

[Award the mark for the stand even if it holds a vertical ruler, with/without supporting the tube]

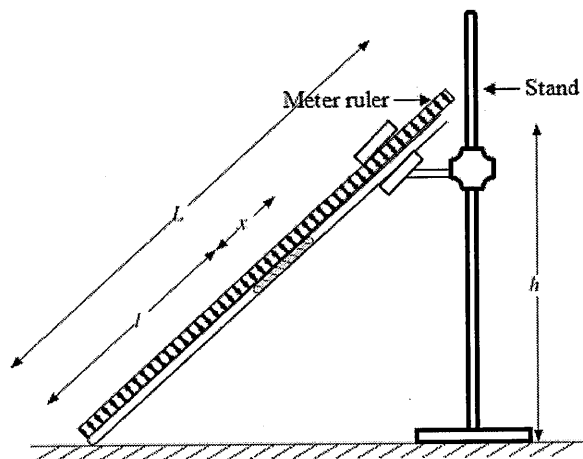

(b) What are the approximate values of length and internal diameter of the quill tube used in this experiment?

Length : ...80-100..cm (01)

Internal diameter : ...2-3.....mm (01)

(c) What should be the approximate length of the mercury column used in this experiment? Underline the correct answer.

(1) 2 cm (2) 10 cm (3) 30 cm (01)

[Award 01 mark for 30 cm or 10 cm]

(d) The internal cross-sectional area of the tube is A and the atmospheric pressure is H (in cm Hg). Here l , x values are in cm and A is in cm^2 .

(i) Write down an expression for the pressure (in cm Hg) of the trapped air column in terms of H , h , x and L .

$$\text{Pressure} = H + \frac{xh}{L} \quad \text{.....(01)}$$

[If a student has included $\rho g(dg)$ term and/or converted parameters into “m” do not award this mark, but award the rest of marks for appropriately correct expressions written later]

- (ii) Applying the Boyle’s law to the trapped air column, write down an expression to determine H in terms of h, x, L, l, A and a constant (k).

$$\left(H + \frac{xh}{L}\right)Al = k \quad \dots\dots(01)$$

[Award the mark even if wrong expression for pressure in (d)(i) is substituted to the Boyle’s law]

- (iii) Rearrange the expression obtained in (d) (ii) above to determine H by plotting a straight line graph.

$$\frac{1}{l} = \left(\frac{Ax}{Lk}\right)h + \frac{AH}{k} \quad \dots\dots (02)$$

[Award 01 mark for rearrangement of expression in (d) (ii) and 01 for correct expression]

- (iv) In the graph mentioned in (d) (iii) above identify the independent and dependent variables.

Independent variable : h (01)

Dependent variable : $\frac{1}{l}$ (01)

[No marks for variables of a wrong expression]

- (v) Label the axes and draw a rough sketch of the graph expected by you. Label the line drawn as P .

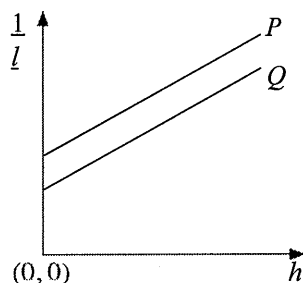

Correct labelling of both axes(01)

Straight line with a positive gradient and a positive intercept(02)

[01 mark for the positive gradient; 01 mark for the positive intercept]

- (vi) Write down an expression for the atmospheric pressure H using the informations extracted from the graph and relevant parameters.

$$\text{Gradient} = \frac{Ax}{kL} \quad \text{Intercept} = \frac{AH}{k}$$

$$\text{Atmospheric pressure } H = \left(\frac{\text{Intercept}}{\text{Gradient}}\right) \frac{x}{L} \quad \dots\dots(02)$$

[Award 01 mark for identifying gradient and intercept]

(e) What is the best experimental procedure to vary h values? Underline the correct answer.

(i) From a lower value to a higher value / from a higher value to a lower value. (01)

(ii) Give the reason

To keep the mercury column inside the quill tube for all readings.

OR To avoid the mercury leaving the tube.

OR To change the pressure of air column from lower values to higher values

OR To change the length of air column from higher values to lower values(01)

(f) If the air trapped in the tube is not dry and contained saturated water vapour throughout the experiment, sketch the expected line on the above graph and label it as Q .

Parallel line with lower intercept(02)

[01 mark for the parallel line; 01 mark for the lower intercept]

3. In order to determine the speed (v) of transverse waves in a stretched wire using resonance, you are provided a sonometer setup as shown in figure (1). You are also provided with a set of tuning forks.

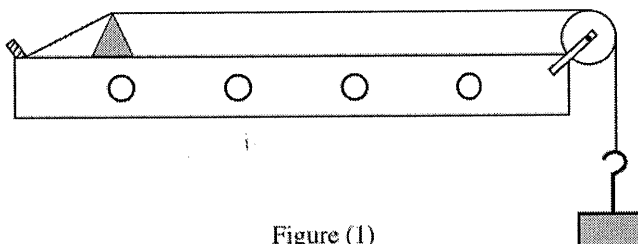

Figure (1)

(a) In this experiment the fundamental mode of resonance of the wire is used. What is the reason for this?

Amplitude/Energy/Loudness of vibrating wire is maximum (in fundamental resonance)(02)

- (b) Draw the wave pattern formed between bridges *P* and *Q* on the following figure (2) for fundamental mode of vibration of the wire. Indicate on same diagram by drawing an arrow, the best position, where the paper rider has to be placed and mark it as *X*.

(For the shape 01 mark, marking *X* - 01 mark)

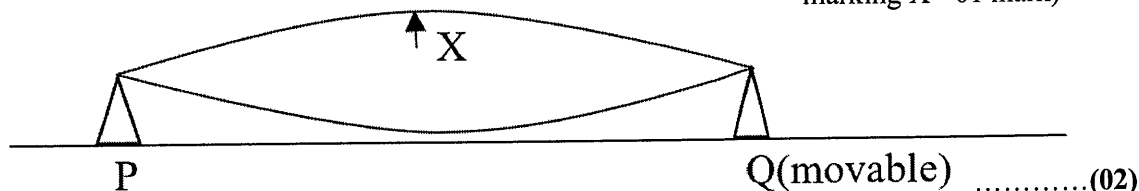

- (c) (i) The distance between the bridges in part (b) above is *l* and the frequency of the tuning fork is *f*. Write down an expression for the speed (*v*) of transverse wave in the sonometer wire in terms of *l* and *f*.

$$v = f\lambda, \quad \dots\dots\dots (01)$$

$$\lambda = 2l, \quad \dots\dots\dots (01)$$

$$v = 2fl$$

(for correct final expression award 02 marks)

- (ii) Rearrange the expression in part (c) (i) above to determine the wave speed *v* by drawing a straight line graph using the set of tuning forks with known frequencies, so that dimension of the gradient to be LT^{-1} .

$$l = \frac{v}{2} \frac{1}{f} \quad \dots\dots\dots (01)$$

(No marks for other forms)

- (iii) State the independent and dependent variables of the graph mentioned in (c) (ii) above.

Independent variable: $\frac{1}{f}$ (01)
 Dependent variable:(01)

- (iv) Coordinates of two points selected to determine the gradient of the above graph are (0.002, 22) and (0.004, 42), Here *l* is measured in cm and *f* is in Hz. Find the value of wave speed *v* in $m s^{-1}$.

$$\text{Gradient} = \frac{v}{2} \quad \dots\dots\dots(01)$$

(for identifying the gradient as $\frac{v}{2}$)

$$\text{gradient} = \frac{(0.42-0.22) m}{(0.004-0.002)s}$$

$$\frac{v}{2} = \frac{0.2}{0.002}$$

$$v = 200 m s^{-1} \quad \dots\dots\dots(01)$$

(disregard the units)

- (d) Considering the length of the prongs of tuning forks, which tuning fork is the best for taking the first measurement? Give reason for your answer.

Tuning fork to be used: Smallest tuning fork/Shortest prongs(01)

Reason: Highest frequency is generated by the tuning fork with shortest prongs/highest frequency tuning fork will give the shortest resonance length of the wire. (01)

- (e) Vibrating directions of two prongs of tuning fork at a given moment is indicated by arrow heads in figure (3). Indicate the vibration direction of particles of stem (S) of the tuning fork at the same moment by drawing an arrow head appropriately on the same figure.

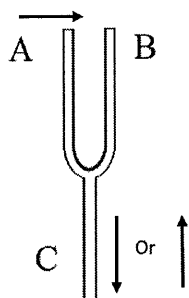

.....(01)

- (f) Masses 1 kg, 2 kg and 3 kg can be used to stretch the sonometer wire. What is the most suitable mass to be used in the experiment? Give reason for your selection.

Most suitable mass to be used is 2.0 kg OR 3.0 kg (01)

Reason; Maximum length of the wire for (fundamental) resonance mode can be obtained and percentage/fractional error of length measurement can be minimized with highest tension of the string. (01)

- (g) If the wire is resonating with frequency f , write down an expression for the amplitude (A) of the wire in terms of f and g when the paper rider just jumps off.

$$\omega^2 A = g \text{ or } 4\pi^2 f^2 A = g$$

.....(01)

$$A = \frac{g}{4\pi^2 f^2} \text{(01)}$$

- (h) Write down a possible error that could happen when determining the resonance length l and action that you would take to minimize it.

Error: Paper rider jumps off within a range of length on the wire *or* uncertainty of obtaining the resonance length.(01)

Action: Repeat the measurements for resonance length several times (and obtain the average length) by changing the distance between two bridges for the same tuning fork

..... (01)

(d) To plot a straight line graph, the student must select appropriate six values for the independent variable. How does the student identify the approximate range of the independent variable in order to select its suitable values?

(Press/close the tap key.) Move the sliding key of the rheostat to one end/ minimum current /maximum resistance and measure the minimum current. Move the sliding key to the other end/maximum current/ minimum resistance and measure the maximum current. These two values give the current range.(02)

[Sliding the key to one end/minimum current/maximum resistance - 01 mark; sliding the key to the other end/ maximum current/minimum resistance - 01 mark]

(e) Write down the procedure that the student must follow to take readings.

Press/close the tap key.(01)

[If a student has selected the plug key instead of the tap key above, award this mark for stating close the key]

Move the sliding key of the rheostat to obtain the current to a selected/ known value and measure the voltmeter reading. Repeat the procedure (for six values of current.)

.....(01)

(f) In this experiment, the graph plotted by the student is given below.

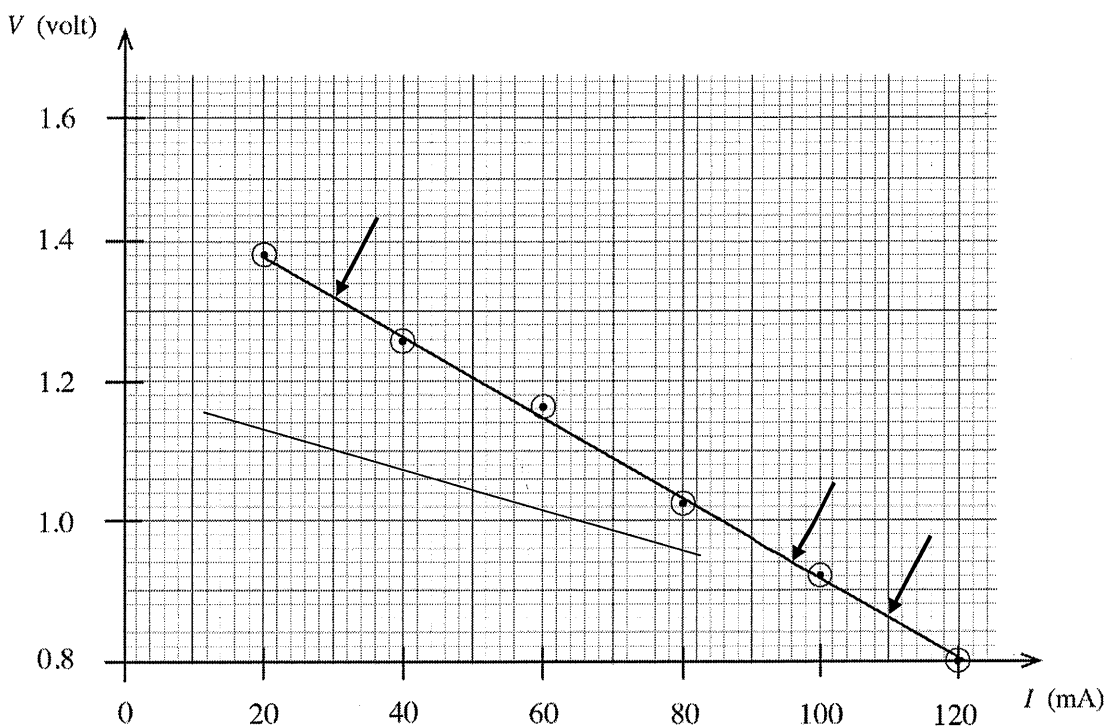

(i) Calculate the gradient of the graph using two suitable points.

Selecting (30, 1.32) and (110, 0.86) OR (96, 0.94) as two suitable points (01)

$$\text{Gradient} = \frac{(1.32 - 0.86)\text{V}}{(30 - 110) \times 10^{-3}\text{A}}$$

$$= -5.75 \Omega \quad [\text{range } (-5.75 \text{ to } -5.78) \Omega] \quad \dots\dots\dots(01)$$

[Award this mark for the gradient with negative sign; disregard the unit]

(ii) Determine the internal resistance r of the cell.

$$r = 5.75 \Omega \quad [\text{range } (5.75 \text{ to } 5.78) \Omega] \quad \dots\dots\dots (01)$$

[Award the mark for identifying r as the positive value of the gradient]

(iii) Determine the e.m.f. E of the cell.

$$E = 1.5 \text{ V} \quad \dots\dots\dots(01)$$

(g) (i) What is the short-circuit current (in ampere) that can be obtained from the given cell? Give your answer to two decimal places.

$$\text{Short-circuit current } I_{sc} = \frac{1.5}{5.75} \quad \dots\dots\dots(01)$$

$$= 0.26 \text{ A} \quad \dots\dots\dots(01)$$

[Award this mark for the division]

(ii) What is the maximum power that can be obtained from the cell by connecting an appropriate resistance?

$$\text{Maximum power} = \left(\frac{I_{sc}}{2}\right)^2 r$$

$$= (0.13)^2 \times 5.75 \quad \dots\dots\dots(01)$$

[Award the mark for the correct expression or substitution]

$$= 0.097 \text{ W } (0.097 - 0.098) \text{ W } \quad [\text{OR } (97-98) \text{ mW}] \quad \dots\dots(01)$$

(h) If the same experiment is done for a nickel-cadmium (Ni-Cd) cell having a lower e.m.f. and a lower internal resistance, sketch the expected line in the same grid given in (f) above.

[Award 01 mark for a lower intercept, 01 mark for a lower gradient] \dots\dots\dots(02)

[Award marks even if the line drawn crosses the line of the graph satisfying the conditions]

සියලු ම හිමිකම් ඇවිරිණි / முழுப் பதிப்புரிமையுடையது / All Rights Reserved

නව කිරීමේ/புதிய பாடத்திட்டம் / New Syllabus

NEW

Department of Examinations, Sri Lanka

අධ්‍යයන වෛද්‍ය සහතික පත්‍ර (උසස් පෙළ) විභාග, 2020
 கல்விப் பொதுத் தராதரப் பத்திர (உயர் தர)ப் பரீட்சை, 2020
 General Certificate of Education (Adv. Level) Examination, 2020

| | | |
|---|-----------------------|----------------|
| භෞතික විද්‍යාව II பொளதிகவியல் II Physics II | PART B – Essay | 01 E II |
|---|-----------------------|----------------|

Answer four questions only.
($g = 10 \text{ m s}^{-2}$)

5. (a) A uniform block of mass M is initially at rest on a horizontal rough plane. Then a horizontal force (P) which is gradually increased from zero is applied to the block. Let the frictional force be F .

- (i) Draw a free-body diagram of the block for the above situation and name all the forces.
- (ii) Sketch the graph of F against P from the initial position until the block moves with acceleration. Mark the limiting frictional force (F_L) and the dynamic frictional force (F_D) on the graph.
- (iii) Write down expressions for the coefficient of limiting friction, μ_L , and the coefficient of dynamic friction, μ_D .

(b) In front-wheel drive cars, the engine is coupled to the front wheels through axles to drive the car. Consider a front-wheel drive car moving on a horizontal straight rough tar road as shown in the figure. The coefficients of friction between the tyres and the tar road are $\mu_L = 0.8$ and $\mu_D = 0.5$ respectively. Consider only the limiting or dynamic frictional forces acting on the car when solving problems below unless otherwise stated.

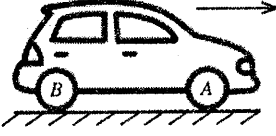

- (i) The situation when the car accelerates on a horizontal straight rough road is shown in the diagram. Copy wheels A and B of the diagram into your answer sheet and mark the frictional force on a front-wheel (A) as F_A and on a rear-wheel (B) as F_B . Also compare the magnitudes of F_A and F_B when accelerating.
- (ii) The mass of the car including the driver is 1200 kg which is equally distributed over all the four wheels. Identifying the correct coefficient of friction acting in this situation, calculate the maximum initial driving force of the car on the horizontal straight tar road.
- (iii) When the car is moving at uniform velocity of 72 km h^{-1} on the horizontal straight road, the total resistance against the motion is 520 N. Find the power of the car at that velocity.
- (iv) Next the car climbs a steep road with angle of inclination 12° to the horizontal at same power as in (b)(iii) above. If the total resistance against motion is now 200 N, find the maximum velocity of climbing. Use $\sin(12^\circ) = 0.2$.
- (v) (I) While the car was again moving at uniform velocity of 72 km h^{-1} on the horizontal straight road, the driver suddenly saw an obstacle on the road at a distance 35 m. When he quickly applied brakes, all four wheels were locked and the tyres started to slip without rolling. Identifying the correct coefficient of friction acting in this situation and by giving appropriate reasoning and calculation, state whether the car would hit the obstacle or not. Neglect the reaction time of the driver before braking.
- (II) If tyres are slipping when brakes are applied, then the car will move a longer distance in a straight line without control which can cause accidents. To avoid such slipping of tyres without rolling, cars are equipped with an anti-lock braking system (ABS). When tyres start to slip during braking, ABS automatically releases the brakes and allows tyres to roll again. This process happens several times a second and the effective coefficient of friction brings close to the value that of limiting friction. When the car is fitted with an ABS, the effective coefficient of friction becomes 0.75. Calculate the new stopping distance of the ABS fitted car for the same situation mentioned in (b)(v)(I) above.
- (vi) Then the car enters a horizontal circular road of radius of curvature 18 m. Assuming that the coefficients of friction are same as in part (b) above, find the maximum velocity that the car can move safely without slipping.

(a) (i)

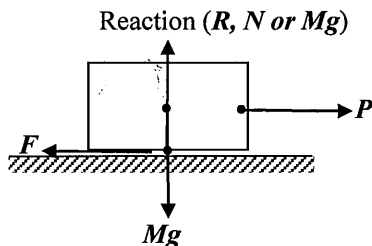

Award marks for the diagram (keeping a gap between object and the surface) and correct labelling

F and P (01)

(F should be drawn at the bottom of the block; P can be drawn at any point on the other side of the block)

R and Mg (01)

(ii)

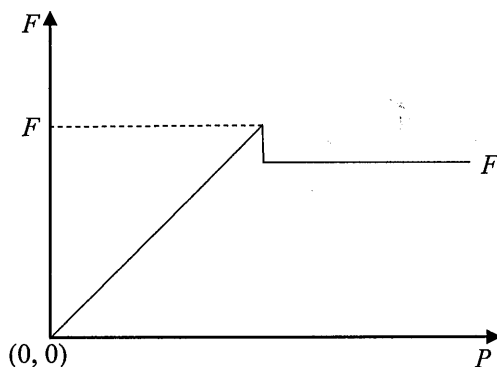

For the correct axes (with origin) and the shape of the curve..... (01)

[Check straight inclined line, peak point and the horizontal line]

For identifying and labelling F_L and F_D (01)

(iii) $\mu_L = \frac{F_L}{R}$ (01)

$\mu_D = \frac{F_D}{R}$ (01)

[Accept word “Reaction” OR N OR “normal reaction” OR Mg instead of R]

(b)(i)

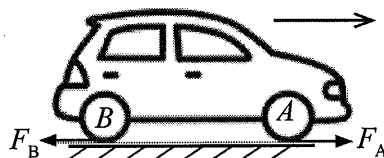

Drawing both forces from the bottom of the tyres and labelling F_A and F_B (01)

$F_A > F_B$ (01)

- (ii) When limiting friction is acting the maximum driving force is exerted and therefore, $\mu_L = 0.8$ is acting in this situation.....(01)

(Award this mark if the student has used $\mu_L = 0.8$ in the following calculation)

Weight on one wheel = $\frac{12000}{4} \times 10$ N (01)

Normal reaction (R) on one wheel = 3000 N

Applying $F = \mu R$

$$F_L = 0.8 \times 3000$$

$$= 2400 \text{ N}$$

The driving force produced from two front wheels = $2F_L$
 = 4800 N (01)

Alternative Method:

[Award full marks if the normal force for the whole weight is calculated and divided by two for front wheels]

- (iii) Converting velocity 72 km h^{-1} into SI unit, 20 m s^{-1} (01)

Power against frictional force is given by the equation

$$P = Fv \text{ (01)}$$

Substituting $F = 520 \text{ N}$ and $v = 20 \text{ m s}^{-1}$

$$P = 520 \times 20$$

$$= 10\,400 \text{ W (or } 10.4 \text{ kW) (01)}$$

- (iv)

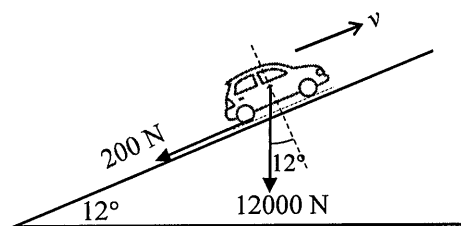

When the car is climbing at uniform velocity, forces acting against the motion consist of two parts.

$$F = 12\,000 \sin 12^\circ + 200 \text{ (02)}$$

[Award 01 mark for finding the component of weight and 01 mark for adding two forces]

$$= 12\,000 \times 0.2 + 200$$

$$= 2\,600 \text{ N}$$

Applying. $P = Fv$
 $10\,400 = 2600 \times v$
 $v = 4 \text{ m s}^{-1}$ (01)

(v) I. When tyres of the car slip the coefficient of dynamic friction is acting
 $\mu_D = 0.5$ (01)

(Award this mark if the student has used $\mu_D = 0.5$ in the following calculation)

Since all four wheels are slipping, the normal reactions of all wheels contribute to the frictional force.

Applying $F = \mu R$
 $F_1 = 0.5 \times 1200 \times 10$ (01)
 $= 6000 \text{ N}$

Applying $F = ma$
 $\rightarrow: -6000 = 1200 \times a_1$ (01)
 $a_1 = -5 \text{ m s}^{-2}$

Applying $v^2 = u^2 + 2as$
 $\rightarrow: 0 = 20^2 - 2 \times 5 \times s_1$ (01)

$s_1 = 40 \text{ m}$ (01)

The car hits the obstacle.(01)

Alternative Method:

Applying the law of conservation of energy

$\frac{1}{2}mv^2 = Fs$ (01)

$\frac{1}{2} \times 1200 \times 20^2 = 6000 \times s_1$ (01)

$s_1 = 40 \text{ m}$ (01)

The car hits the obstacle.(01)

II. When ABS are acting the coefficient of friction becomes 0.75.

Applying $F = \mu R$
 $F_2 = 0.75 \times 1200 \times 10$ (01)
 $= 9000 \text{ N}$

Applying $F = ma$
 $\rightarrow: -9000 = 1200 \times a_2$
 $a_2 = -7.5 \text{ m s}^{-2}$

Applying $v^2 = u^2 + 2as$
 $\rightarrow: 0 = 20^2 - 2 \times 7.5 \times s_2$ (01)

$s_2 = 26.7 \text{ m (OR 26.6 m)}$ (01)

The car does not hit the obstacle.

Alternative Method:

Applying the law of conservation of energy

$$\frac{1}{2}mv^2 = Fs$$

$$\frac{1}{2} \times 1200 \times 20^2 = 9000 \times s_2 \dots\dots\dots (01)$$

$$s_2 = 26.7 \text{ m (OR 26.6 m)} \dots\dots\dots (01)$$

The car does not hit the obstacle

(vi)

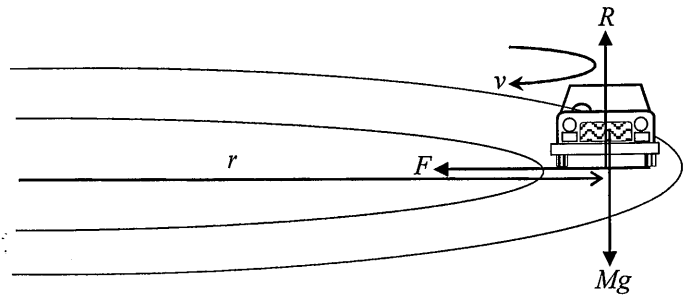

When moving without slipping $\mu_L = 0.8$ is acting (01)
 (This mark can be awarded if the student has used $\mu_L = 0.8$ in the following calculation)

Also the normal reactions of all four wheel ($mg = 12000 \text{ N}$) are acting.
 The frictional force (F) between tyres and the road toward the center of the circular road must provide the centripetal force to move on the circular road (of radius r at the maximum safe speed v) without slipping.

The centripetal force = $F = \frac{mv^2}{r}$

For circular motion $\mu mg = \frac{mv^2}{r} \dots\dots\dots (01)$

$$v = \sqrt{\mu rg}$$

$$v = (0.8 \times 18 \times 10)^{1/2} \dots\dots\dots (01)$$

$$v = 12 \text{ m s}^{-1} \dots\dots\dots (01)$$

6. Read the following passage and answer the questions.

Figure (1) shows a cross-section of a human eye. The combination of the corneal and the eye lenses focuses light on to the retina. But light refracts far more when passing from air into the cornea, since the difference in refractive indices between air ($n_a = 1$) and cornea ($n_c = 1.38$) is large.

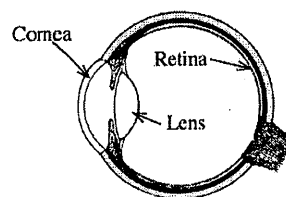

Figure (1)

The corneal lens and the eye lens can be considered as convex lenses of fixed focal length and of variable focal length respectively. The focal length of the eye lens could be changed by the action of ciliary muscles. This combination could be treated as a two thin convex lenses in contact.

Two common defects of vision are near-sightedness and far-sightedness. Usually these defects can be corrected by the use of suitable lenses. Nowadays these defects also could be corrected using a computer-controlled ultra-violet (UV) laser rays by removing microscopic amounts of tissue from the cornea and thereby reshaping the cornea. This procedure is known as a LASIK surgery. The aim is to restore normal eyesight, without the need for eye-glasses or contact lenses.

These type of lasers, unlike continuous lasers in bar-code readers, are pulsed. They emit energy as short pulses of about 10fs duration ($1\text{ fs} = 10^{-15}\text{ s}$). These lasers are ideal for eye surgery, because highly intense pulses of UV light is absorbed only by a very thin layer of tissue of the cornea. The incident UV light decomposes the thin layer into a vapour of small molecules, which fly away from the corneal surface rapidly leaving behind very little energy which won't cause any damage to the adjacent tissues.

These type of pulsed lasers are also commonly used in the production of microelectronic devices, and semiconductor integrated circuits (IC). [Hint: Power of a converging lens is positive and given by dioptries (D)].

- (a) Refraction of light entering the eye mostly happens at the air-cornea interface. What is the reason for this?
- (b) (i) If the angle of incidence of a monochromatic light ray entering the cornea is i , and the angle of refraction is r , write down an expression for the refractive index of the cornea n_c , in terms of i and r .
(ii) When, $i = 30^\circ$, r becomes $21^\circ 14'$. What is the angle of deviation of the ray in this situation?
- (c) (i) Distance from the compound lens to the retina and to the near point of the eye is 2.5 cm and 25.0 cm respectively. By drawing corresponding ray diagrams, calculate the **minimum** and **maximum** powers of the compound lens.
(ii) If the power of the lens formed by the cornea is +30 D, calculate the corresponding powers of the eye lens in the two situations mentioned in (c)(i) above.
- (d) (i) The near point of a defective eye of a person is 50 cm. What is the power of the compound lens of this defective eye when the person reads a newspaper located at a distance 50 cm from his eye?
(ii) If the power of the lens formed by the cornea is +30 D, what is the corresponding power of the eye lens in this situation?
(iii) Without wearing an eye-glass if the person decides to correct his vision by a LASIK surgery, what should be the power of the reshaped corneal lens?
(iv) If the person decides to wear an eye-glass without doing a laser surgery what is the type and the power of the eye-glass that the person should wear?
- (e) What is the advantage of using pulsed UV lasers instead of continuous lasers in eye surgery?
- (f) During a laser surgery, a short pulse of ultraviolet light is projected onto the cornea of a person. It makes a spot of 0.5 mm in radius on the cornea and delivers 0.55 mJ of energy on to the spot in the corneal tissue. Calculate the thickness of the tissue removed from the corneal surface. The corneal tissue is initially at 30°C . Assume that the removed tissue temperature is increased to 100°C and then vapourises without further temperature increase. [Density of the corneal tissue = 10^3 kg m^{-3} ; specific heat capacity of corneal tissue = $4.0 \times 10^3\text{ J kg}^{-1}\text{ K}^{-1}$; specific latent heat of vapourization of corneal tissue = $2.52 \times 10^6\text{ J kg}^{-1}$; Take $\pi = \frac{22}{7}$]
- (g) Figure (2) shows a train of pulses created by a pulsed UV laser. The energy contained in a single pulse is 20 mJ.
(i) If the width of a single pulse is 10 fs, determine the peak power (power in a single pulse) of the laser beam.
(ii) If the pulse repetition rate is 500 Hz, determine the mean power of the laser beam.
- (h) State another use of UV pulsed lasers.

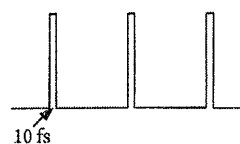

Figure (2)

(a) Difference in index of refraction between air and cornea is large/Refractive index of air is 1 whereas it is 1.38 for the cornea..... (01)

(b) (i) $n_c = \frac{\sin i}{\sin r}$ (01)

(ii) Angle of deviation = $30^\circ - 21^\circ 14'$ (01)

[For the subtraction]
= $8^\circ 46'$ (01)

(c) (i) Maximum focal length occurs when $u = \infty$
Therefore the maximum focal length = 2.5 cm

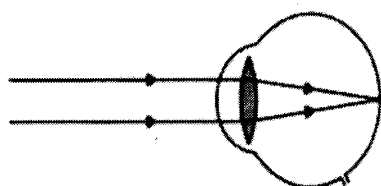

..... (02)

[To earn this marks two parallel rays should converge at the retina; deduct 01 mark if at least one arrow is not marked on a single ray; drawing the total boundary of the eye is not essential, but a boundary should be drawn at the point where rays meet each other; deduct one mark if rays meet without a boundary]

Hence the minimum power of the compound lens = $\frac{1}{2.5} \times 100$
= +40 D (01)
(when awarding marks disregard the + sign)

Minimum focal length occurs when $u = 25$ cm.

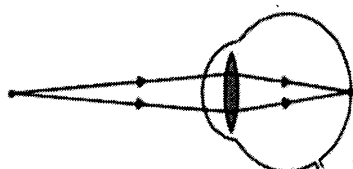

..... (02)

[To earn this mark two diverging rays should converge at the retina; if 01 mark was deducted earlier due to a missing arrow, do not look at the arrows here; drawing the total boundary of the eye is not essential, but a boundary should be drawn at the point where the image is formed; if 01 mark was deducted earlier due to missing boundary do not look at the boundary here]

Applying $\frac{1}{v} - \frac{1}{u} = \frac{1}{f}$ for the compound lens, (01)

[For writing the lens formula]

$$-\frac{1}{2.5} - \frac{1}{25} = \frac{1}{f} \text{ (01)}$$

$$\frac{1}{f} = -\frac{11}{25}$$

Hence the maximum power of the compound lens = $\frac{11}{25} \times 100$
 = +44 D (01)

(ii) Applying $\frac{1}{F} = \frac{1}{f_1} + \frac{1}{f_2}$ (or $D = d_1 + d_2$) for the lens combination, (01)
 [For writing the equation for the compound lens]

$$40 = 30 + d_2$$

Power of the eye lens = +10 D (01)

$$44 = 30 + d_2$$

Power of the eye lens = +14 D (01)

(d) (i) Applying $\frac{1}{v} - \frac{1}{u} = \frac{1}{f}$ for the compound lens,

$$-\frac{1}{2.5} - \frac{1}{50} = \frac{1}{f} \dots\dots\dots (01)$$

$$\frac{1}{f} = -\frac{21}{50}$$

Hence the power of the compound lens = $\frac{21}{50} \times 100$
 = +42 D..... (01)

(ii) Power of the eye lens = 42 – 30
 = +12 D (01)

(iii) The power of the reshaped cornea = 44 – 12
 = +32 D (01)

(iv) $\frac{1}{50} - \frac{1}{25} = \frac{1}{f}$
 $\frac{1}{f} = -\frac{1}{50}$
 Hence the power of the eye-glass = $\frac{1}{50} \times 100$
 = +2 D..... (01)

Type – Convex/converging (01)

(e) It is absorbed in a very thin layer of tissue, decomposing that tissue into a vapour (of small molecules, which fly away from the surface so fast) leaving too little energy behind to damage the adjacent tissue. / It will not damage the adjacent tissue..... (01)

(f) If the thickness of the tissue removed from the corneal surface is d ,

$$\text{Mass of the removed corneal tissue} = \frac{22}{7} \times (0.5 \times 10^{-3})^2 \times d \times 10^3 \dots\dots\dots (01)$$

$$\text{Heat absorbed form } 30^\circ\text{C to } 100^\circ\text{C} = \frac{22}{7} \times (0.5 \times 10^{-3})^2 \times d \times 10^3 [4 \times 10^3 \times 70] \dots (01)$$

[for the $mc\Delta\theta$ term]

$$\text{Heat absorbed to vaporize the tissue} = \frac{22}{7} \times (0.5 \times 10^{-3})^2 \times d \times 10^3 \times 2.52 \times 10^6 \dots (01)$$

[for the mL term]

$$0.55 \times 10^{-3} = \frac{22}{7} \times (0.5 \times 10^{-3})^2 \times d \times 10^3 [4 \times 10^3 \times 70 + 2.52 \times 10^6] \dots\dots\dots (01)$$

[For equating L.H.S. to R.H.S.]

$$d = 2.5 \times 10^{-7} \text{ m (0.25 } \mu\text{m) [(2.5 – 2.6) } \times 10^{-7} \text{ m; (0.25 - 0.26) } \mu\text{m]} \dots\dots\dots (01)$$

(g) (i) Peak power = $\frac{20 \times 10^{-3}}{10^{-14}}$

$$= 2 \times 10^{12} \text{ W} \dots\dots\dots (01)$$

(ii) Average power = $20 \times 10^{-3} \times 500$

$$= 10 \text{ W} \dots\dots\dots (01)$$

(h) Production of microelectronic devices / production of integrated circuits..... (01)

(Any one of the above uses)

7. (a) (i) Stress-strain curve for a metal wire is shown in figure (1). Identify the characteristic points *A*, *B*, *C* and *D*.
 (ii) If the wire is stretched up to the value depicted by point *C* and released, what will happen to the wire?
 (iii) What is represented by the area under the stress-strain curve?

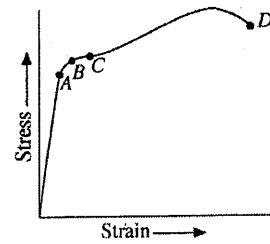

Figure (1)

- (b) Iron beams are used to support heavy loads in the construction of structures and buildings. When a uniformly distributed load is applied on a beam with a rectangular cross section supported at its two ends, the upper part of the beam is compressed and becomes shorter. Similarly the lower part of the beam is elongated and becomes longer. The length of the middle layer of the beam does not change and it is known as the neutral axis.

The distribution of forces acting on the upper part of the beam of thickness *d* is illustrated in figure (2). The figure is not drawn to scale. Copy this diagram on to your answer sheet and draw the distribution of forces acting on the lower part of the beam.

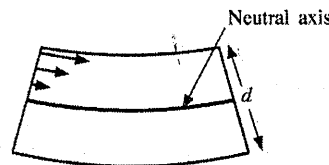

Figure (2)

- (c) The lower section of the beam in figure (2) is shown in figure (3). The radius of curvature of the neutral axis is *r* which subtends an angle α (in radians) at the center *O*. The length of the neutral axis of the beam is *l*.

- (i) Write down an expression for *l* in terms of *r* and α .
 (ii) Write down an expression for *l* in terms of *r*, *d* and α . Here *l* is the length of the bottom layer (*B*) of the lower section of the beam.
 (iii) Show that the average value of the strain existing on the lower section of the beam is given by $\frac{d}{4r}$.
 (d) (i) What is the force acting along the neutral axis (*NN'*)?
 (ii) If the average value of the tensile force acting on the lower section of the beam is *F*, what will be the force acting along the bottom layer (*B*) of the lower section of the beam?
 (iii) If the width of the beam is *w* and the Young's modulus of iron is *Y*, show that force *F* is given by $F = \frac{wd^2Y}{8r}$.
 (iv) When the lower section of the beam is subjected to a average tensile stress of $1.0 \times 10^8 \text{ N m}^{-2}$, determine the value of radius *r*. Young's modulus of iron, $Y = 2.0 \times 10^{11} \text{ N m}^{-2}$; $d = 20 \text{ cm}$.
 (v) If $l = 5.0 \text{ m}$, determine α in radians.
 (vi) Using $\cos(\frac{\alpha}{2}) = 0.9997$, calculate the depression δ of the midpoint (*M*) of the neutral axis of the beam.

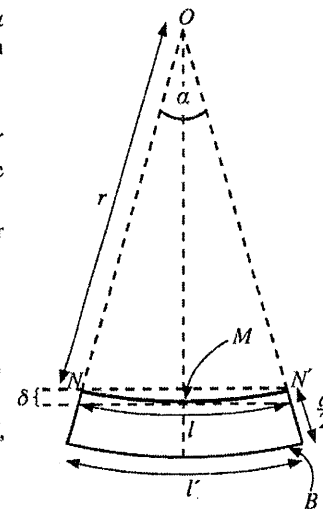

Figure (3)

- (e) Figure (4) shows a rectangular beam and an I (or H)-shaped beam made out of iron. In the construction field, I-shaped beams are generally used instead of rectangular beams. Giving reasons state the advantage of this.



Figure (4)

- (a) (i) A – Proportional limit..... (01)
 B – Elastic limit..... (01)
 C - Yield point..... (01)
 D – Breaking point..... (01)

(ii) The wire will not return to its initial (original) length/ the final length will be longer than the initial (original) length/ a permanent extension will occur in the wire/ a permanent deformation occur in the wire (02)

(iii) Energy stored per unit volume (02)

[No marks for just stating energy stored]

(b)

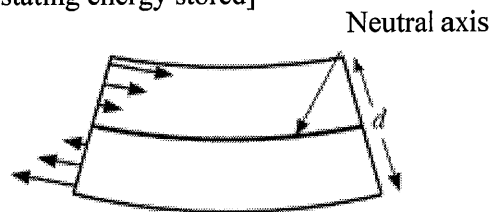

Arrows (at least two) pointing towards left at the left end *OR* right at the right end *OR* at both ends (tensile forces) (01)

[Arrows could be drawn inside the beam]

Length of the arrows gradually increasing from neutral axis to the bottom..... (01)

Arrow heads linearly increasing as shown (01)

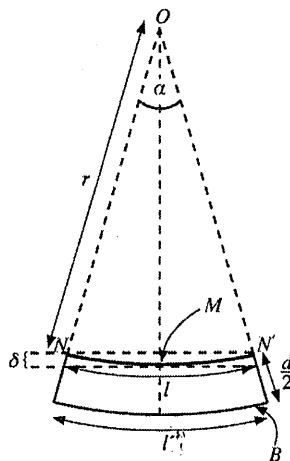

(c) (i) $l = r\alpha$ (01)

(ii) $l' = (r + \frac{d}{2})\alpha$ (01)

(iii) Extension of the bottom layer = $l' - l$ (01)

[For the subtraction]

$$= \frac{d}{2} \alpha$$

Average extension of the lower section of the beam = $\frac{l' - l}{2}$

(01)

[For dividing the extension by 2]

$$= \frac{d}{4} \alpha$$

∴ the average strain of the lower part of the beam = $\frac{d \alpha}{4 l}$ (01)

[For dividing extension by unstretched length l]

$$= \frac{d \alpha}{4 r \alpha} = \frac{d}{4 r}$$

(d) (i) The force acting along the neutral axis (NN') = 0 (01)

(ii) The force acting along the bottom layer (B) of the lower section of the beam = $2F$... (01)

(iii) Tensile stress = $\frac{F}{\frac{wd}{2}}$ (01)

$Y = \frac{2F}{wd} \times \frac{4r}{d}$ (01)

[For equating Young's modulus to Tensile stress/Tensile strain]

$$\therefore F = \frac{wd^2 Y}{8r}$$

(iv) $Y = \frac{\text{Tensile stress}}{\text{Tensile strain}}$

$$\frac{d}{4r} = \frac{1.0 \times 10^8}{2.0 \times 10^{11}}$$

$$r = \frac{d \times 2.0 \times 10^{11}}{4 \times 1.0 \times 10^8} = \frac{20 \times 10^{-2} \times 2.0 \times 10^{11}}{4 \times 1.0 \times 10^8}$$
 (01)

[For the correct substitution]

$r = 100 \text{ m}$ (02)

(v) $\alpha = \frac{l}{r} = \frac{5}{100}$

$\alpha = 0.05 \text{ rad}$ (01)

(vi) Depression = $r \left[1 - \cos \left(\frac{\alpha}{2} \right) \right]$ (02)
 = $100(1 - 0.9997) = 100 \times 0.0003$
 = 0.03 m (3.0 cm) (01)

(e) The maximum compression occurs at the top layers of the upper section of the beam. ... (01)

Similarly the maximum elongation occurs at the bottom layers of the lower section of the beam

..... (01)

Therefore the best advantage of an I-beam is that the material is present where it should be and in right quantities.

This makes the beam more economical/less expensive/lighter/less mass/less weight..... (01)

8. A defibrillator is a medical instrument that is used to restore the rhythmic pattern of heart after a cardiac arrest of a patient. It gives a high energy electric shock in a short burst to the heart through a set of electrodes across the patient's chest by discharging charge stored in a capacitor.

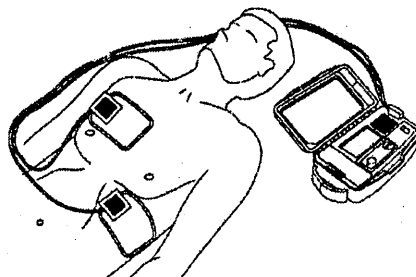

- (a) A defibrillator delivers 48 J of energy to a heart patient by discharging a capacitor initially charged to a potential difference of 400 V.
- Derive an expression for the energy stored W in a capacitor in terms of capacitance C and the potential difference V across the capacitor.
 - What is the capacitance of the capacitor in the device?
 - Calculate the amount of charge stored in the capacitor.
 - Assuming that the total charge calculated in part (iii) was sufficient to pass a constant current through the body with 12 ms time period, calculate this constant current.
 - What is the effective resistance of the path of the current calculated in (a) (iv) above?
- (b) (i) A parallel plate capacitor is filled with a medium of dielectric constant k . Derive an expression for electric field intensity E in the medium in terms of charge stored in the capacitor Q , plate area A , permittivity of free space ϵ_0 and k , by using Gauss's law.
- If the charged capacitor mentioned in (a) above is a parallel plate capacitor with plate area of 80 cm^2 filled with a medium of dielectric constant $k = 5000$, what is the value of the electric field intensity in the medium. $\epsilon_0 = 9.0 \times 10^{-12} \text{ F m}^{-1}$.
 - Determine the separation d between the plates of this capacitor.
- (c) (i) In order to apply an electric shock with the appropriate energy based on the patient, five capacitors of equal capacitance mentioned in (a) above and equal potential difference of 400 V across each capacitor have been connected in series instead of one capacitor. Calculate maximum energy that can be supplied to a patient after connecting five capacitors in series?
- What would be the maximum energy that can be supplied to a patient if five capacitors of equal capacitance mentioned in above part (a) are connected in parallel with a potential difference of 400 V?
 - Out of series and parallel connections of capacitors mentioned in (c) (i) and (c) (ii) above the series connection is recommended for the defibrillator. Giving reasons briefly explain this.
- (d) (i) What factors determine the process of point or corona discharge?
- If the breakdown electric field intensity of the medium mentioned in (b) (ii) above is $8.0 \times 10^8 \text{ V m}^{-1}$, will this capacitor get damaged? Give reasons.
- (e) Suppose the capacitor in (b) above is initially charged to Q_0 using a potential difference of V_0 . If the charge and the potential difference of the capacitor after 12 ms are equal to $0.37Q_0$ and $0.37V_0$ respectively, what percentage of energy stored in the capacitor has been released to the patient during this period. [Take $(0.37)^2 = 0.14$]

(a). (i). Initial voltage = 0

After charging, voltage difference between two plates = V

Average voltage used to store charge Q , $= \frac{0+V}{2}$ (01)

Energy stored in the Capacitor, $W = \frac{V}{2}Q = \frac{V}{2} \times CV$

Therefore, energy stored in the capacitor, $W = \frac{1}{2}CV^2$ (01)

(No marks, if $W = \frac{1}{2}CV^2$ is written directly)

Alternative method

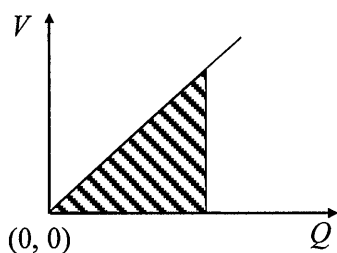

From the graph, energy stored in the capacitor, $W = \text{area under the curve } OR \frac{1}{2}VQ$ (01)

Energy stored in the Capacitor, $W = \text{Area under the curve}$

Energy stored in the Capacitor, $W = \frac{1}{2}VQ = \frac{1}{2}V \times CV$

$W = \frac{1}{2}CV^2$ (01)

(ii). Energy stored in a capacitor $W = \frac{1}{2}CV^2$

$48 = \frac{1}{2}C \times (400)^2$ (01)

(award the mark for substitution)

Capacitance of the capacitor in the device $C = 600 \times 10^{-6}\text{F}$ (600 μF)(01)

(iii). By applying $Q = CV$

Total charge stored in the capacitor $Q = 600 \times 10^{-6} \times 400$ (01)

(award the mark for substitution)

$Q = 0.24 \text{ C}$ (01)

- (iv). By applying $Q = It$
 $0.24 = I \times 12 \times 10^{-3}$ (01)
 (award the mark for substitution)
 Constant current pass through the body within 12 ms time period,
 $I = 20 \text{ A}$ (01)
- (v). By applying $V = IR$
 $400 = 20R$ (01)
 (award the mark for substitution)
 Effective resistance of the path mentioned, $R = 20 \ \Omega$ (01)

(b).(i). Consider the Gaussian surface shown in the figure.

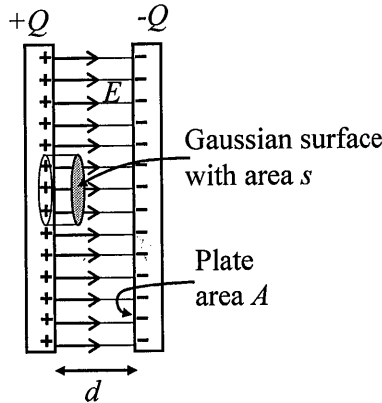

For the Figure (for selecting a proper Gaussian surface, with indicating electric field lines) ... (01)

$$\text{Charge density } \sigma = \frac{Q}{A}$$

$$\text{Charge enclosed by the Gaussian surface, } = \sigma s$$

$$\text{Total outward flux, } \phi = E s$$

If the flux due to electric field E is ϕ , from Gauss's law,

$$\phi = \frac{\sigma s}{\epsilon} \quad (\text{OR } \phi = \frac{Q}{\epsilon}) \quad \dots\dots(01)$$

Since $\epsilon = k\epsilon_0$,

$$E s = \frac{\sigma s}{k\epsilon_0}$$

$$E = \frac{Q}{A k \epsilon_0} \quad \dots\dots(01)$$

(ii). $E = \frac{Q}{A k \epsilon_0}$

$$E = \frac{0.24}{80 \times 10^{-4} \times 5000 \times 9 \times 10^{-12}} = \frac{2}{3 \times 10^{-9}} \quad \dots\dots(01)$$

(award the mark for substitution)

Electric field intensity in the medium, $E = 6.67 \times 10^8 \text{ V m}^{-1}$ (OR $6.66 \times 10^8 \text{ V m}^{-1}$)(01)

(iii). $E = \frac{V}{d}$

Separation between the plates, $d = \frac{V}{E}$

$$d = \frac{400 \times 3 \times 10^{-9}}{2} \dots\dots\dots(01)$$

(award the mark for substitution)

$$d = 6.0 \times 10^{-7} \text{m} \dots\dots\dots(01)$$

OR

$$d = \frac{400}{6.67 \times 10^8} \text{ (OR } \frac{400}{6.66 \times 10^8} \text{)} \dots\dots\dots(01)$$

$$d = 6.0 \times 10^{-7} \text{m (OR } 5.9 \times 10^{-7} \text{m)} \dots\dots\dots(01)$$

Alternative method

$$d = \frac{Ak\epsilon_0}{C}$$

$$d = \frac{80 \times 10^{-4} \times 5000 \times 9 \times 10^{-12}}{600 \times 10^{-6}} \dots\dots\dots(01)$$

(award the mark for substitution)

$$d = 6.0 \times 10^{-7} \text{m} \dots\dots\dots(01)$$

(c) (i). Energy of one capacitor 48 J

Therefore, total energy of five series capacitors, $W_s = 5 \times 48 \dots\dots\dots(01)$

$W_s = 240 \text{ J} \dots\dots\dots(01)$

(Award 02 marks if final answer is given)

Alternative method

If the equivalent capacitance is C,

For series combination $\frac{1}{C} = \frac{1}{C_1} + \frac{1}{C_2} + \dots$

In (a).(ii). Capacitance = 600 μF

$$\frac{1}{C} = \frac{5}{600} \quad \text{or } C = 120 \mu\text{F} \dots\dots\dots(01)$$

Equivalent Capacitance $C = 120 \mu\text{F}$

Voltage drop between the equivalence capacitance = $400 \text{ V} \times 5 = 2000 \text{ V}$

Total energy of five series capacitors, $W_s = \frac{1}{2} \times 120 \times 10^{-6} \times (2000)^2$

$W_s = 240 \text{ J} \dots\dots\dots(01)$

(ii).

Energy of one capacitor 48 J

Therefore, total energy of five parallel capacitors, $W_p = 5 \times 48$ (01)

$W_p = 240$ J(01)

(Award 02 marks if final answer is given)

Alternative method

If the equivalent capacitance is C,

For parallel combination $C = C_1 + C_2 + \dots$

In (a).(ii). capacitance = 600 μ F

$C = (600 + 600 + 600 + 600 + 600)\mu\text{F} = 3000 \mu\text{F}$ (01)

Voltage drop 400 V

$W_p = \frac{1}{2} \times 3000 \times 10^{-6} \times (400)^2$

$W_p = 240$ J(01)

(iii). Since the voltage across the electrodes is high the intensity of current pulse is greater/it can provide a large electric shock(02)

(d).(i). Very high electric field/high charge density/high voltage/shape of the conductor (sharp point, thin wire etc.)/ radius of curvature(01)

Medium (air/ fluid /moisture)(01)

(ii). the electric field strength of the capacitor(medium) $E = 6.67 \times 10^8 \text{ V m}^{-1}$

The breakdown electric field strength in the medium = $8.0 \times 10^8 \text{ V m}^{-1}$

The breakdown electric field strength in the medium is greater than the electric field strength of the capacitor(01)

Therefore capacitor will not get damaged(01)

(e). Initial energy $W_1 = \frac{1}{2} V_0 Q_0$

Energy after 12ms $W_2 = \frac{1}{2} \times 0.37V_0 \times 0.37Q_0$

$W_1 - W_2 = \frac{1}{2} \times V_0 \times Q_0 - \frac{1}{2} \times 0.37V_0 \times 0.37Q_0$ (01)

$W_1 - W_2 = \frac{1}{2} \times V_0 \times Q_0 (1 - 0.37 \times 0.37)$

Percentage of energy released by the capacitor during the first 12.0 ms

$= \frac{\frac{1}{2} V_0 Q_0 (1 - 0.37 \times 0.37)}{\frac{1}{2} V_0 Q_0} \times 100$ (01)

= 86 %(01)

9. Answer either part (A) or part (B) only.

Part (A)

- (a) (i) Write down an expression for the energy dissipation in a resistor of resistance R , when a direct current (d.c.) I flows through it in time t .
- (ii) The variation of sinusoidal alternating voltage V with time t is shown in figure (1). Write down an expression for root mean square voltage V_{rms} in terms of peak voltage V_p .
- (iii) Out of the four lines A, B, C, D drawn in figure (1) which lines represent V_p and V_{rms} respectively?
- (iv) State the main advantage of using high tension a.c. voltage in long distance power transmission.
- (v) Rewrite the expression obtained for energy dissipation in (a) (i) above for a.c. currents.

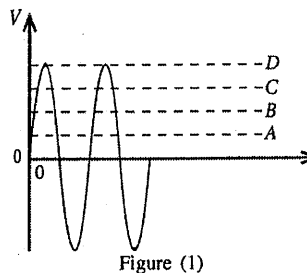

Figure (1)

- (b) A part of an electrical circuit connected to the a.c. main supply is shown in figure (2).

Following electrical appliances are connected to the main 230 V supply using a copper wire AB of cross sectional area 1 mm^2 and length 10 m. Assume that the voltage drop across AB is negligible.

- L_1 – Rice cooker of 1200 W,
- L_2 – Refrigerator of 300 W,
- L_3 – Electric kettle of 800 W

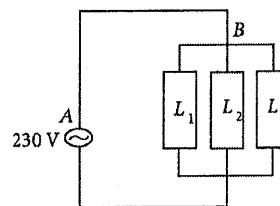

Figure (2)

- (i) Calculate the maximum current flow in the wire.
- (ii) Calculate the temperature rise when the maximum current flows through the wire for 10 s. Assume that the wire is completely insulated and no loss of heat to the outside. Mass of the wire is 100 g. Resistivity and the specific heat capacity of copper are $1.8 \times 10^{-8} \Omega \text{ m}$ and $360 \text{ J kg}^{-1} \text{ }^\circ\text{C}^{-1}$ respectively.
- (iii) Instead of a single copper wire a composite wire made of few such wires connected in parallel is used in high current flowing applications. Explain how this arrangement reduces heat dissipation.
- (c) An electricity meter measures the amount of electrical energy consumption in kWh. It uses eddy currents to rotate a thin circular aluminium disc. The number of revolutions of the aluminium disc is directly proportional to the electrical energy consumption.

- (i) A solenoid is placed over the horizontal aluminium disc, perpendicular to its plane as illustrated in figure (3). Suppose that the current through the solenoid is increasing in the direction as indicated in the figure. Copy the figure (3) in to your answer sheet and draw the magnetic flux lines due to current in the solenoid and eddy current loops on the disc, indicating their directions.

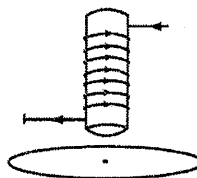

Figure (3)



Figure (4)

- (ii) To decelerate the free revolutions of the disc when the power consumption is stopped, a permanent magnet is fixed as shown in the figure (4). Explain how the deceleration of the disc happen.
- (d) During the period from 6.00 p.m. to 10.00 p.m. for a particular day at a house, the number of revolutions per minute (r.p.m) of the disc is measured. The graph in figure (5) shows its variation. The electricity meter is calibrated in such a way that 500 rotations is equivalent to 1 kWh.

- (i) Calculate the electrical power consumption at 8.30 p.m.
- (ii) If the electricity unit price between 7.00 p.m. to 9.00 p.m. is Rs. 40.00 per kWh and rest of the time is Rs. 10.00 per kWh, calculate the total cost for the period from 6.00 p.m. to 10.00 p.m.

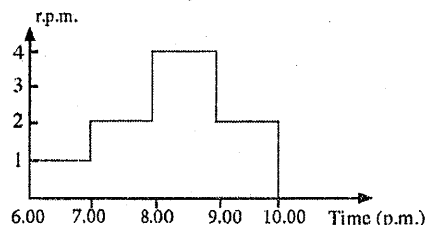

Figure (5)

(a)

(i) $E = I^2 R t$ (02)

(ii) $V_{rms} = \frac{V_p}{\sqrt{2}}$ (02)

(iii) D (01)
 C (01)

(iv) Ability to change (increase/decrease) voltage using transformers/To reduce power loss (by decreasing current)(01)

(v) $E = I_{rms}^2 R t$ OR $E = \frac{V_p^2 t}{2R}$ OR $E = \frac{V_{r.m.s}^2 t}{R}$ (01)
 (No mark for stating $I^2 R t$ OR $\frac{V^2 t}{R}$)

(b)

(i) Total power consumption = $P_1 + P_2 + P_3 = 1200 + 300 + 800 = 2300$ W(01)
 (Award this mark for addition of wattages or addition of individual currents)

Applying $P = VI$,

$$I = \frac{2300}{230}$$

= 10 A(01)

(if the student assumes peak current as the maximum current, then the answer should be $10\sqrt{2}$ A or 14.12 A)

(ii) Joule heat $\Delta Q = I^2 R t$

Resistance of the wire, $R = \frac{\rho l}{A}$ (01)

$$= \frac{(1.8 \times 10^{-8} \times 10)}{1 \times 10^{-6}}$$
(01)

(For the substitution)

$$\Delta Q = \frac{10^2 \times (1.8 \times 10^{-8} \times 10) \times 10}{1 \times 10^{-6}}$$
 (01)

(For the substitution)

$$= 1.8 \times 10^2 \text{ J}$$

$$\Delta Q = mc\Delta\theta$$

$$100 \times 10^{-3} \times 360 \Delta\theta = 1.8 \times 10^2$$
(02)

(01 mark for LHS and 01 for equating)

$$\Delta\theta = \frac{180}{100 \times 360} \times 10^3 = 5 \text{ }^\circ\text{C}$$
(01)

(iii) Current flowing is divided among wires and less current through each wire *or* the effective resistance reduces.(02)

(c) (i) Drawing magnetic flux lines and correct directions(02)
 (01 mark for drawing the lines; 01 mark for the direction; At least two flux lines are needed)

Drawing eddy current lines and correct directions(02)
 (01 mark for drawing the lines; 01 mark for the direction; for eddy currents one circle is enough)

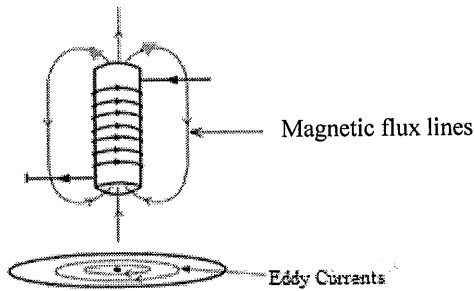

(ii) Eddy currents generated on the disc create a magnetic force which acts against the motion(02)

(d) (i) 1 kW h is equivalent to $1 \times 1000 \times 60$ W min(01)
 Revolutions per minute at 8.30 pm is 4

$$\therefore 4 \text{ rpm is equivalent to } \frac{1 \times 1000 \times 60}{500} \times 4$$

Electric power consumption for 4 rpm = 480 W(01)

(ii) 7.00 to 8.00 p.m. total turns = 2×60
 8.00 to 9.00 p.m. total turns = 4×60
 \therefore total turns during 7.00 to 9.00 = $6 \times 60 = 360$ (01)

Energy consumption or units consumed = $\frac{360}{500}$ kW h(01)

$$\text{Total cost} = \frac{360}{500} \times 40.00 = \text{Rs. } 28.80$$

6.00 to 7.00 p.m. total turns = 1×60
 9.00 to 10.00 p.m. total turns = 2×60

\therefore total turns during off peak hours = $3 \times 60 = 180$ (01)

$$\text{Total cost for off peak hours} = \frac{180}{500} \times 10.00 = \text{Rs. } 3.60$$

$$\text{Total cost for the period 6.00 pm to 10.00 pm} = 28.80 + 3.60 = \text{Rs. } 32.40 \quad \text{..... (01)}$$

Part (B)

(a) Write down the 'golden rules' applicable to an ideal operational amplifier (op-amp) when it operates in negative feedback mode.

(b) The op-amp circuit shown in figure (1) is known as a 'Differential amplifier' since it amplifies the difference between the two input voltages V_2 and V_1 . The voltages at the non-inverting input and inverting input of the op-amp circuit are V_+ and V_- respectively and V_0 is the output voltage of the op-amp.

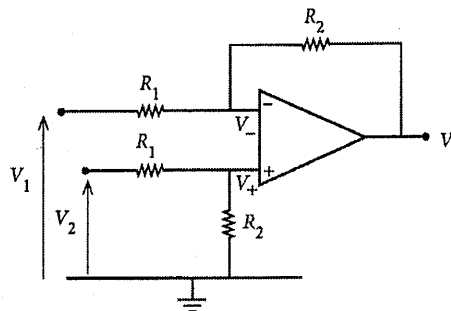

Figure (1)

- (i) Write down an expression for V_+ in terms of V_2 , R_1 and R_2 .
 - (ii) Write down an expression for V_- in terms of V_2 , R_1 and R_2 .
 - (iii) Derive an expression for V_0 in terms of V_1 , V_2 , R_1 and R_2 .
 - (iv) Deduce an expression for V_0 , if $R_1 = R_2 = R$.
- (c) The above circuit in figure (1) can be modified to activate a burglar alarm. The modified circuit is shown in figure (2). The right arm of the bridge circuit has two equal resistors of resistance R_1 and the left arm consists of a 50Ω resistor and a light dependent resistor (LDR) which is sensitive to infra-red (IR) light. A narrow beam of IR light is allowed to fall on to the LDR continuously. When a burglar (B) enters the building he blocks the IR beam falling on to the LDR.

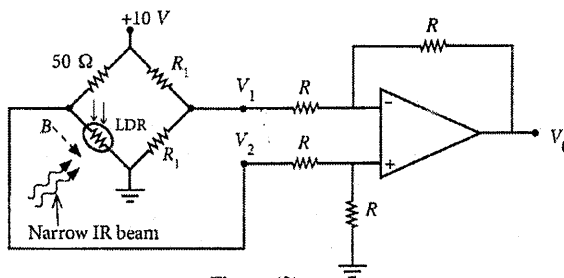

Figure (2)

- (i) When the IR beam falls on to the LDR its resistance is equal to 50Ω . Determine the corresponding values of V_1 , V_2 and V_0 .
 - (ii) When the burglar crosses the IR beam the resistance of the LDR increases to $10^6 \Omega$. Determine the corresponding values of V_1 , V_2 and V_0 in this situation.
- (d) (i) Now the output V_0 of the op-amp is connected to the S input of an S-R flip-flop as shown in figure (3). The R input is grounded via a two-way switch. The alarm should sound when $Q = 1$. Write down the input logic levels of S and R for the following two situations.

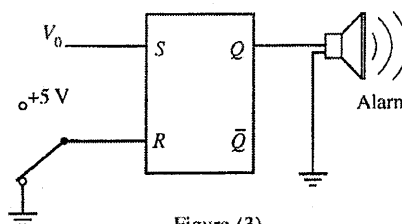

Figure (3)

- (1) When the IR beam is incident on the LDR.
- (2) When the burglar crosses the IR beam.
- (ii) Write down the truth table of an S-R flip-flop.
- (iii) Show that the alarm will sound when the burglar crosses the IR beam.
- (iv) Explain why is it desirable to use a flip-flop in this situation?
- (v) Later the alarm has to be stopped. How could this be achieved? Give reasons for your answer.

(a) (1) The input resistance of the noninverting and inverting (+/-) inputs is infinite. OR No current flows into the noninverting and inverting (+/-) inputs of the op amp. / OR $I_+ = I_- = 0$ (02)

(2) (In a circuit with negative feedback,) the output of the op amp will try to adjust its output so that the voltage difference between the noninverting and inverting (+ and -) inputs is zero

OR $V_+ = V_-$ OR $V_+ - V_- = 0$ (02)

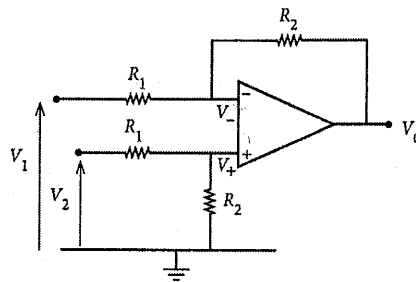

(b)

(i) $V_+ = \frac{R_2}{R_1 + R_2} V_2$ (02)

(ii) $V_- = \frac{R_2}{R_1 + R_2} V_2$ (02)

(iii) $\frac{V_1 - V_-}{R_1} = \frac{V_- - V_0}{R_2}$ (02)

$$V_0 = R_2 \left[V_- \left(\frac{1}{R_1} + \frac{1}{R_2} \right) - \frac{V_1}{R_1} \right] \Rightarrow R_2 \left[V_- \left(\frac{R_1 + R_2}{R_1 R_2} \right) - \frac{V_1}{R_1} \right]$$

After substituting for V_- ,

$V_0 = \frac{R_2}{R_1} (V_2 - V_1)$ (02)

(iv) $V_0 = (V_2 - V_1)$ (02)

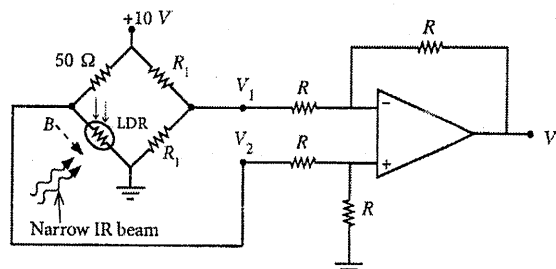

(c)

(i) $V_1 = 5 \text{ V}$ (01)

$V_2 = 5 \text{ V}$ (01)

$V_o = 0$ (01)

(ii)

$V_1 = 5 \text{ V}$ (01)

$V_2 = 10 \text{ V}$ (01)

$V_o = 5 \text{ V}$ (01)

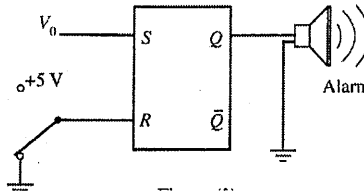

(d) (i) (1) $S = 0 ; R = 0$ (01)

(2) $S = 1 ; R = 0$ (01)

(ii)

| S | R | Q |
|-----|-----|--|
| 0 | 0 | Previous State/No change/ Q_{old} |
| 0 | 1 | 0/(Reset) |
| 1 | 0 | 1/(Set) |
| 1 | 1 | Forbidden/Not valid/?/-/Not defined/Impossible |

..... (02)

[To earn 02 marks all entries should be correct]

(iii) When the burglar cross the beam $Q = 1$ since $S = 1$ and $R = 0$ (set state) (01)

(iv) When the burglar leaves / when $S = 0$ and $R = 0$ the flip-flop will remember the set state [previous state/ $Q = 1$ state/earlier state]. (01)

Therefore the alarm will ring continuously. (01)

(v) The two-way key should be connected to +5 V/OR to the other location. (01)

Then the logic level at R is 1/ OR at 5 V/OR reset state/OR $S = 0, R = 1$ (01)

So the alarm will stop sounding since $Q = 0$ (01)

10. Answer either part (A) or part (B) only.

Part (A)

Geothermal energy is heat energy trapped in hot regions known as hotspots in the Earth. When underground water comes in contact with hotspots, it produces superheated water and traps between the rocks at high pressure as hot water reservoirs.

- (a) An underground hot water reservoir of volume $1.0 \times 10^8 \text{ m}^3$ and temperature 200°C exists at high pressure in a hotspot region. Earth is drilled up to the hot water reservoir and steam is fed to a turbine through a vertical cylindrical pipe as shown in the figure (1) (drawn not to scale). Assume that the mean specific heat capacity and mean density of superheated water between 200°C and 100°C are $4.5 \times 10^3 \text{ J kg}^{-1} \text{ K}^{-1}$ and 900 kg m^{-3} respectively.

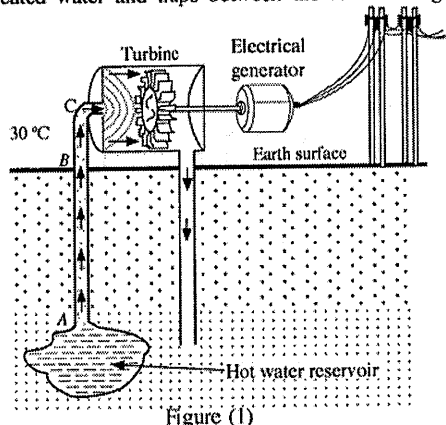

Figure (1)

- (i) Write down an expression for heat released ΔQ by an object of specific heat capacity c and mass m when the temperature is decreased by $\Delta\theta$.
- (ii) Calculate the amount of heat released by superheated water when superheated water at 200°C in the reservoir is reduced to the boiling point (100°C) of water. Assume that after inserting the pipe to the reservoir, the temperature of the superheated water drops to 100°C at atmospheric pressure.
- (iii) Calculate the total mass of steam that can be produced using the energy released from superheated water calculated in (a)(ii) above. The specific latent heat of vapourization of water is $2.5 \times 10^6 \text{ J kg}^{-1}$.

- (b) A cylindrical pipe made of a metal of thermal conductivity k_1 whose inner and outer radii are r_1 and r_2 respectively is covered with thick insulating material of thermal conductivity k_2 . The outer radius of the composite pipe is r_3 . The cross-section of the pipe is shown in figure (2). At the steady state the inner and outer temperatures of the composite pipe are θ_1 and θ_2 ($\theta_1 > \theta_2$) respectively. Show that the rate of heat flow $\frac{Q}{t}$ passing radially outwards per unit length of the composite pipe is given by

$$\frac{Q}{t} = \frac{\theta_1 - \theta_2}{\frac{(r_2 - r_1)}{k_1 \pi (r_2 + r_1)} + \frac{(r_3 - r_2)}{k_2 \pi (r_3 + r_2)}}$$

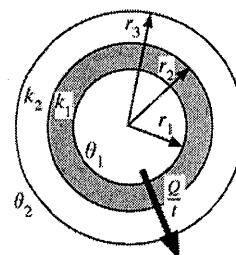

Figure (2)

- (c) Geothermal power plants generate electricity by using geothermal energy. Steam at 100°C obtained from the underground reservoir (a) above is fed to the turbine through a cylindrical metal pipe of inner and outer radii of 48 cm and 52 cm respectively. The pipe is covered with 6 cm thick insulation material. Thermal conductivities of the metal and insulation material are $100 \text{ W m}^{-1} \text{ K}^{-1}$ and $\frac{2}{11} \text{ W m}^{-1} \text{ K}^{-1}$ respectively.
- (i) If the average air temperature of the environment is 30°C , calculate the rate of heat loss at steady state from the steam at 100°C to the environment per unit length of the pipe between B and C. Take $\pi = 3$. In the calculation neglect the term containing 10^{-4} compared to the 10^{-1} term.
 - (ii) If the length of the pipe from the surface of the Earth to the turbine (between B and C) is 500 m, calculate the rate of heat loss from the steam to the environment from B to C.
 - (iii) Assume that rate of heat loss per unit length inside the Earth (from A to B) is half of that from B to C. The length of AB is 2 km. Calculate the total rate of heat loss from the whole pipe. (A to C).
 - (iv) Using steam the turbine produces 8.58 MW mechanical power (output power). If the mechanical efficiency of the turbine is 40%, calculate the input power given by steam to the turbine.
 - (v) How many years this geothermal power plant will function from heat generated by the superheated water calculated in (a) (ii) above. (Take 1 year = $3 \times 10^7 \text{ s}$)

(a).

(i). $\Delta Q = mc\Delta\theta$ (02)

(ii). Mass of super-heated water = $V\rho$ (01)
 $= 1.0 \times 10^8 \times 900$
 $= 9.0 \times 10^{10} \text{ kg}$

Amount of heat released by super-heated water = $mc\Delta\theta$ (02)
 $= 9.0 \times 10^{10} \times 4500 \times (200-100)$

(One mark for taking temperature difference and one mark for rest of the equation)

$= 9.0 \times 10^{10} \times 4500 \times 100$ (01)
 $= 4.05 \times 10^{16} \text{ J}$

(iii). Heat used to vaporization of water $m_1L = 4.05 \times 10^{16} \text{ J}$ (02)
 $m_1 \times 2.5 \times 10^6 = 4.05 \times 10^{16}$

[one mark for the LHS (m_1L) term and the other mark for equating m_1L to the answer obtained in a(ii)]

Mass of steam that can be produced using the energy released from superheated water
 $m_1 = 1.62 \times 10^{10} \text{ kg}$ (01)

(b). Rate of heat transfer $\frac{Q}{t} = kA \frac{\Delta\theta}{\Delta l}$ (02)

Suppose, the temperature of the boundary between two pipes is θ

Rate of heat transfer in radial direction of the metal pipe through a unit length

$\frac{Q}{t} = k_1 2\pi \frac{(r_1+r_2)}{2} \frac{(\theta_1-\theta)}{(r_2-r_1)}$ (02)

(One mark for taking the average area/radius of the curved surface of the tube, other mark for the rest of the expression)

$(\theta_1 - \theta) = \left(\frac{Q}{t}\right) \frac{1}{\pi k_1} \frac{(r_2-r_1)}{(r_2+r_1)}$

At the steady state rate of heat pass in radial direction of the insulating pipe through a unit length

$\frac{Q}{t} = k_2 2\pi \frac{(r_2+r_3)}{2} \frac{(\theta-\theta_2)}{(r_3-r_2)}$ (01)

$(\theta - \theta_2) = \left(\frac{Q}{t}\right) \frac{1}{\pi k_2} \frac{(r_3 - r_2)}{(r_3 + r_2)}$

Hence,

$(\theta_1 - \theta_2) = \left(\frac{Q}{t}\right) \frac{1}{\pi k_1} \frac{(r_2-r_1)}{(r_2+r_1)} + \left(\frac{Q}{t}\right) \frac{1}{\pi k_2} \frac{(r_3-r_2)}{(r_3+r_2)}$ (01)

$$\frac{Q}{t} = \frac{\theta_1 - \theta_2}{\frac{(r_2 - r_1)}{k_1 \pi (r_2 + r_1)} + \frac{(r_3 - r_2)}{k_2 \pi (r_3 + r_2)}}$$

(c)(i).

$$\frac{Q}{t} = \frac{\theta_1 - \theta_2}{\frac{(r_2 - r_1)}{k_1 \pi (r_2 + r_1)} + \frac{(r_3 - r_2)}{k_2 \pi (r_3 + r_2)}}$$

$$\frac{Q}{t} = \frac{100 - 30}{\frac{4 \times 10^{-2}}{100 \times 3 \times (48 + 52) \times 10^{-2}} + \frac{6 \times 10^{-2}}{\frac{2}{11} \times 3 \times (52 + 58) \times 10^{-2}}} \dots\dots\dots(03)$$

(one mark for each term of the above expression)

$$\frac{Q}{t} = \frac{70}{\frac{4 \times 10^{-2}}{100 \times 3 \times (48 + 52) \times 10^{-2}} + \frac{6 \times 10^{-2}}{\frac{2}{11} \times 3 \times (52 + 58) \times 10^{-2}}}$$

$$\frac{Q}{t} = \frac{70}{\frac{4}{100 \times 3 \times 100} + \frac{6 \times 11}{2 \times 3 \times 110}}$$

$$\frac{Q}{t} = \frac{70}{\frac{4 \times 10^{-4}}{3} + 10^{-1}}$$

At the steady state rate of heat pass in radial direction of the insulating pipe through a unit length

$$\frac{Q}{t} = 700 \text{ W m}^{-1} \dots\dots\dots(01)$$

(Disregard the unit)

(ii). Rate of heat loss to the surroundings through the pipe $BC = 700 \times 500 \dots\dots\dots(01)$

$$= 3.5 \times 10^5 \text{ W} \dots\dots\dots(01)$$

(iii) Rate of heat loss to the surroundings through the pipe $AB = \frac{700}{2} \times 2000 \dots\dots\dots(01)$

$$= 7.0 \times 10^5 \text{ W}$$

Rate of heat loss to the surroundings through the pipe $AC = 3.5 \times 10^5 + 7.0 \times 10^5 \dots\dots\dots(01)$

(For addition)

Total rate of heat to the surroundings loss through the pipe = $10.5 \times 10^5 \text{ W} \dots\dots\dots(01)$

(iv).

$$\frac{\text{output mechanical power generated by the turbine}}{\text{input power given by the steam}} = 40\%$$

$$\frac{8.58 \times 10^6}{\text{input power given by the steam}} = \frac{40}{100} \quad \dots\dots\dots(01)$$

$$\begin{aligned} \text{Input power given by the steam} &= 2.145 \times 10^7 \text{ W} && \dots\dots\dots(01) \\ &[(2.14 - 2.15) \times 10^7 \text{ W}] \end{aligned}$$

(v). Total rate of heat loss through the pipe = $10.5 \times 10^5 \text{ W}$

Steam power enter into the turbine = $2.145 \times 10^7 \text{ W}$

$$\begin{aligned} \text{Generated power of the well} &= 2145 \times 10^4 + 105 \times 10^4 \\ &\dots\dots\dots(01) \\ &(\text{for addition}) \end{aligned}$$

Generated power of the well = $2250 \times 10^4 \text{ W}$

Total amount of heat released by superheated water = $4.05 \times 10^{16} \text{ J}$

$$\text{Total time period} = \frac{4.05 \times 10^{16}}{2250 \times 10^4 \times 3.0 \times 10^7} \text{ years} \quad \dots\dots\dots(02)$$

(One mark for dividing by 3.0×10^7 and the other mark for the rest of the division)

$$\begin{aligned} \text{Total time period} &= 60 \text{ years} && \dots\dots\dots(01) \\ &[59 - 61 \text{ years}] \end{aligned}$$

Part (B)

A monochromator is an optical instrument that can be used to produce a monochromatic beam of photons. In a photoelectric experiment a monochromatic beam of photons produced by the monochromator passes through a rectangular aperture and perpendicularly incident on a metal plate kept in a vacuum chamber as shown in the figure (1).

Initially the monochromator produces a beam of photons of wavelength 100 nm.

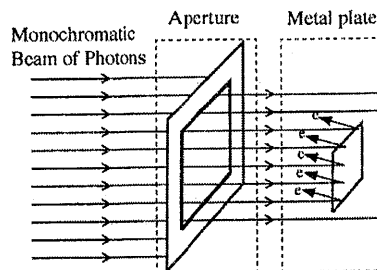

Figure (1)

Take $hc = 1240 \text{ eV nm}$ for all relevant calculations. Here h is Planck constant and c is speed of light.

- (a) (i) Name the wavelength region of electromagnetic spectrum where the 100 nm of radiation belongs to.
 (ii) Calculate the corresponding energy of the 100 nm photon in eV.
 (iii) Considering the wave-particle duality, calculate the momentum of the photon with the above energy. ($h = 6.6 \times 10^{-34} \text{ J s}$)
- (b) (i) Derive an expression for intensity I (energy flowing through a unit area per unit time) of a monochromatic parallel beam of n number of photons each having energy E and passing through an area A during a time t .
 (ii) If the intensity of 100 nm monochromatic beam of photons shown in figure (1) above is $9.92 \times 10^{-8} \text{ W m}^{-2}$ and the area of the rectangular aperture is $3 \text{ mm} \times 4 \text{ mm}$, how many photons passes through the aperture per unit time? ($1 \text{ eV} = 1.6 \times 10^{-19} \text{ J}$)
 (iii) If the metal plate shown is a silver plate of area $2 \text{ mm} \times 2 \text{ mm}$, calculate the number of emitted photoelectrons in a unit time from the plate, assuming each incident photon emits one photoelectron.
- (c) (i) The work function of the silver plate used in this experiment is 4.0 eV. Find the minimum and maximum values of kinetic energy of the emitted photoelectrons in eV.
 (ii) The monochromator is adjusted to produce monochromatic beams of photons of wavelengths from 100 nm to 500 nm in 50 nm increments and for each wavelength, maximum kinetic energy (K_{max}) of photoelectrons emitted from the silver plate is measured. The variation of K_{max} with the wavelength of photon beam is shown in the figure (2). What are the values corresponding to points A and B?
 (iii) The same experiment is repeated for a gold plate with a work function of 5.0 eV. Copy the graph in figure (2) in your answer sheet and draw clearly the corresponding curve for the gold plate in the same graph.
 (iv) Same photon beam of wavelength of 200 nm is incident on both plates separately. The corresponding photocurrents measured from the silver and gold plates are i_s and i_g respectively. State whether $i_g = i_s$ or $i_g > i_s$ or $i_g < i_s$. Give reason for your answer. Assume each photon incident on the plates ejects one photoelectron.
- (d) It has been reported that radiation of 222 nm can be used for inactivation of Covid-19 viruses. However, there is a maximum limit of 24 mJ cm^{-2} per 8 hour exposure time for a human body when 222 nm radiation is used in medical applications. What should be the maximum power of a point source which emits 222 nm radiation placed 20 cm from a person's Covid-19 virus contained palm? (Take $\pi = 3$)

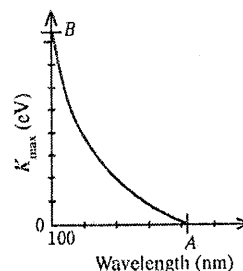

Figure (2)

* * *

(a) (i) Ultraviolet (UV)(02)

(ii) $E = \frac{hc}{\lambda}$ (01)

$$E = \frac{1240}{100}$$

$E = 12.4 \text{ eV}$ (01)

(iii) $\lambda = \frac{h}{p}$ (01)

$$p = \frac{6.6 \times 10^{-34}}{100 \times 10^{-9}}$$
(01)

$p = 6.6 \times 10^{-27} \text{ kg m s}^{-1} \text{ (N s)}$ (02)

(Two marks for the correct answer with correct unit, Only one mark for correct answer, no mark for only the unit)

(b) (i) Intensity (I) = $\frac{\text{Total Energy}}{A \times t}$ (01)

$I = \frac{nE}{At}$ (01)

(Award 02 marks for the correct equation without writing the above first step)

(ii) Energy of photons passing through the area of 1 m^2 in unit time = $9.92 \times 10^{-8} \text{ J}$

Energy of photons passing through the area of $3 \text{ mm} \times 4 \text{ mm}$ in unit time = $9.92 \times 10^{-8} \times 3 \times 4 \times 10^{-6}$ (01)

= $119.04 \times 10^{-14} \text{ J}$

Energy of 100 nm photon in eV = 12.4 eV

Energy of 100 nm photon in J = $12.4 \times 1.6 \times 10^{-19} \text{ J}$

Number of photons (n) = $\frac{119.04 \times 10^{-14}}{12.4 \times 1.6 \times 10^{-19}}$ (01)

(mark for dividing by the energy of a 100 nm photon in J)

$n = 6.0 \times 10^5$ (01)

- (iii) Number of photons in the area of $3 \text{ mm} \times 4 \text{ mm} = 6.0 \times 10^5$
 Number of incident photons on the silver plate
 $= \frac{6.0 \times 10^5}{3 \times 4} \times 2 \times 2 \dots\dots\dots(01)$
 $= 2 \times 10^5$
 Number of emitted photoelectrons in a unit time $= 2 \times 10^5 \dots\dots\dots(01)$

- (c) (i) Minimum value of kinetic energy $= 0 \dots\dots\dots(01)$
 Maximum value of kinetic energy
 $K_{max} = \frac{hc}{\lambda} - \phi \text{ OR } (12.4 - 4.0) \dots\dots\dots(01)$
 $= 8.4 \text{ eV} \dots\dots\dots(01)$

- (ii) $A = 1240 / 4.0$
 $= 310 \text{ nm} \dots\dots\dots(01)$
 $B = 8.4 \text{ eV} \dots\dots\dots(01)$

- (iii) The corresponding cut-off wavelength for gold plate $= 1240/5.0$
 $= 248 \text{ nm} \dots\dots\dots(01)$
 Maximum kinetic energy of the photoelectrons ejected by the photons
 of wavelength 100 nm
 $= 12.4 - 5.0$
 $= 7.4 \text{ eV} \dots\dots\dots(01)$
 Correct shape of the graph $\dots\dots\dots(01)$
 (03 marks can be given for the curve indicating corresponding $\lambda_{\text{cut-off}}$
 and K_{max} values ; exact values or reasonable representation of the
 exact values)

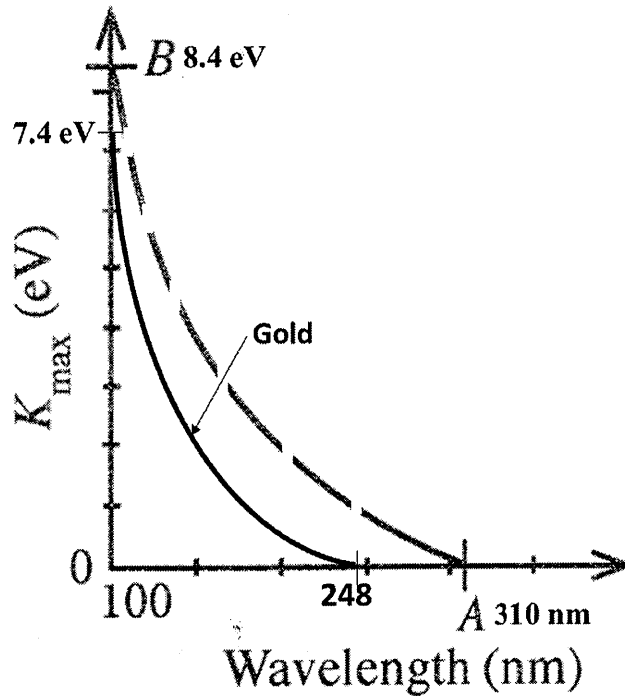

(iv) $i_s = i_g$ (01)

Reason: Number of photoelectrons emitted are same(01)

(d) Radiation intensity that can be safely applied on the 1cm^2 of palm =

$$\frac{24 \times 10^{-3}}{8 \times 3600} \text{(01)}$$

Suppose power of source is P

Intensity from the source on the 1cm^2 of palm =

$$\frac{P}{4\pi \times 20 \times 20} \text{(01)}$$

$$\frac{P}{4 \times 3 \times 20 \times 20} = \frac{24 \times 10^{-3}}{8 \times 3600} \text{(01)}$$

(Award this mark for equating the above intensity to R.H. side)

$$P = 4 \times 10^{-3} \text{ W} \text{(02)}$$

(One mark for correct unit, no mark for only the unit)