



G.C.E. Advanced Level  
Grade 13  
**Combined Mathematics I**  
Three hours



Channel NIE®  

**Part A**  
**Answers**

01. Using the principal of **Mathematical induction**, prove that

$$\sum_{r=1}^n 2r(2r^2 - 1) = n(n+1)(n^2 + n - 1) \text{ for all } n \in \mathbb{Z}^+$$

Answer -

$$\begin{aligned} \text{when } n=1 \quad \text{L.H.S} &= \sum_{r=1}^1 2r(2r^2 - 1) \\ &= 2.1(2.1^2 - 1) \\ &= 2 // \end{aligned}$$

$$\begin{aligned} \text{L.H.S.} &= 1(1+1)(1^2 + 1 - 1) \\ &= 2 // \end{aligned}$$

$$\therefore \text{ for } n = 1 \quad \text{L.H.S.} = \text{R.H.S.} \quad \text{—————} \textcircled{5}$$

$\therefore$  The result is true for  $n = 1$

If the result is true for  $n = p$ , ( $p \in \mathbb{Z}^+$ ) (assumption)

$$\sum_{r=1}^p 2r(2r^2 - 1) = P(p+1)(p^2 + p - 1) \text{ ———} \textcircled{1} \text{ ———} \textcircled{5}$$

now, the proof of result for  $n=(p+1)$

for this proof, add the  $(p+1)^{\text{th}}$  term of the series  $T_{(p+1)}$  to both sides of  $\textcircled{1}$ , assumption

Then

$$\begin{aligned} \textcircled{1} \Rightarrow \sum_{r=1}^p 2r(2r^2 - 1) + T_{p+1} &= p(p+1)(p^2 + p - 1) + T_{(p+1)} \\ \sum_{r=1}^{(p+1)} 2r(2r^2 - 1) &= p(p+1)(p^2 + p - 1) + 2(p+1)[2(p+1)^2 - 1] \textcircled{5} \\ &= (p+1)[p^3 + p^2 - p + 4p^2 + 8p + 2] \\ &= (p+1)(p^3 + 5p^2 + 7p + 2) \\ &= (p+1)(p+2)(p^2 + 3p + 1) \\ &= (p+1)((p+1)+1)[(p+1)^2 + (p+1) - 1] \textcircled{5} \end{aligned}$$

$\therefore$  The result is true for  $n = (p+1)$  if it is true for  $n = p$ . Also the result was true for  $n = 1$

$\therefore$  According to principal of **mathematical induction**, the result is true for all  $n \in \mathbb{Z}^+$   $\textcircled{5}$

02. Sketch the graphs of  $y = 3|3-x|$  &  $y = |x|-2$  on the same  $oxy$  plane. Hence determine the set of all  $x \in \mathbb{R}$ , such that  $|x-1|-3|x-4| > 2$ .

Answer -

	$x = 0$	$x = 3$
$y_1 = 3(3-x)$	$y_1 = 3(3-x)$	$y_1 = -3(3-x)$
$= 9 - 3x$	$= 9 - 3x$	$= 3x - 9$
	$y_1 = 9$	$y_1 = 0$
$y_2 = -x - 2$	$y_2 = x - 2$	$y_2 = x - 2$
	$y_2 = -2$	$y_2 = 1$

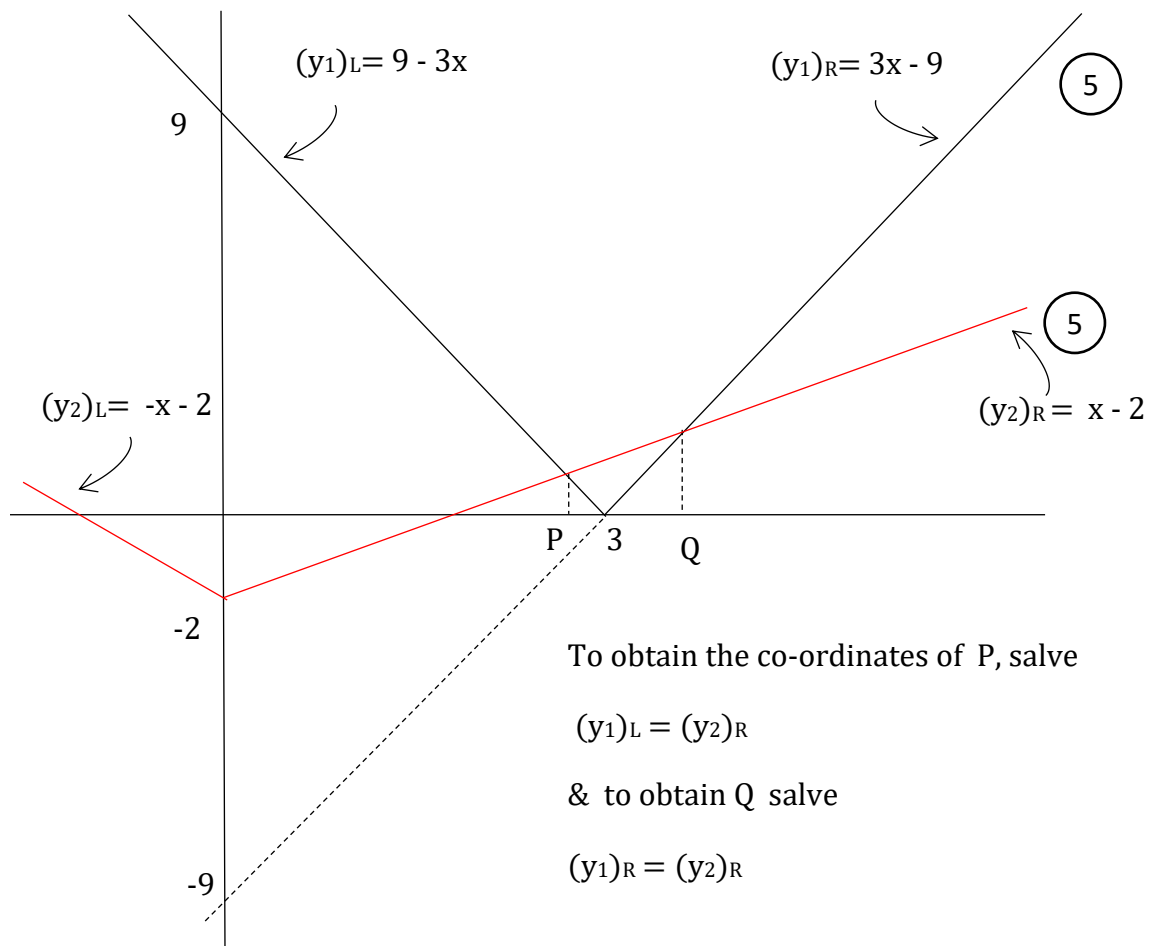

To obtain the co-ordinates of P, solve

$$(y_1)_L = (y_2)_R$$

& to obtain Q solve

$$(y_1)_R = (y_2)_R$$

$$\begin{array}{l}
 \boxed{P} \longrightarrow (y1)L = (y2)R \\
 \qquad \qquad \qquad 9 - 3x = x - 2 \\
 \qquad \qquad \qquad x = \frac{11}{4} // \\
 \\
 \boxed{Q} \longrightarrow (y1)R = (y2)R \\
 \qquad \qquad \qquad 3x - 9 = x - 2 \\
 \qquad \qquad \qquad x = \frac{7}{2} //
 \end{array}
 \left. \vphantom{\begin{array}{l} \boxed{P} \\ \boxed{Q} \end{array}} \right\} \textcircled{5}$$

$\therefore$  for the  $x$  values in between  $P$  &  $Q$ ,  $y1 < y2$

$$\therefore y1 < y2 \Leftrightarrow \frac{11}{4} < x < \frac{7}{2}$$

$$3|3-x| - x < |x| - 2 \Leftrightarrow \frac{11}{4} < x < \frac{7}{2} \quad \text{—————} \textcircled{5}$$

$x \rightarrow (x - 1)$  by substituting

$$3|3-(x-1)| < |x-1| - 2 \Leftrightarrow \frac{11}{4} < (x-1) < \frac{7}{2}$$

$$3|4-x| < |x-1| - 2 \Leftrightarrow \frac{11}{4} + 1 < x < \frac{7}{2} + 1$$

$$3|x-4| < |x-1| - 2 \Leftrightarrow \frac{15}{4} < x < \frac{9}{2} \quad \text{—————} \textcircled{5}$$

range of  $x$  which satisfies  $\therefore |x-1| - 3|x-4| > 2$

$$\text{is } \underline{\underline{\frac{15}{4} < x < \frac{9}{2}, x \in \mathbb{R}}}}$$

03. Let  $Z = 2 + i$  and  $Z' = x + iy$

Prove that

$$\frac{|Z| + Z'}{|Z| - Z'} = \frac{|Z|^2 - |Z'|^2 + 2|Z| \operatorname{Im}(Z')i}{|Z|^2 + |Z'|^2 - 2|Z| \operatorname{Re}(Z')}$$

Further, if  $|Z| = |Z'|$  then deduce that  $\frac{|Z| + Z'}{|Z| - Z'}$  is absolutely imaginary.

Answer -

$$\begin{aligned} \frac{|Z| + Z'}{|Z| - Z'} &= \frac{\sqrt{5} + (x+iy)}{\sqrt{5} - (x+iy)} = \frac{(\sqrt{5} + x) + iy}{(\sqrt{5} - x) - iy} \\ &= \frac{[(\sqrt{5} + x) + iy][(\sqrt{5} - x) + iy]}{[(\sqrt{5} - x) - iy][(\sqrt{5} - x) + iy]} \quad \text{--- (5)} \\ &= \frac{[(5 - x^2) - y^2] + [y(\sqrt{5} + x) + y(\sqrt{5} - x)]i}{(\sqrt{5} - x)^2 + y^2} \\ &= \frac{5 - (x^2 + y^2) + 2\sqrt{5}y i}{5 + (x^2 + y^2) - 2\sqrt{5}x} \quad \text{--- (5)} \\ &= \frac{|Z|^2 - |Z'|^2 + 2|Z| \operatorname{Im}(Z')i}{|Z|^2 + |Z'|^2 - 2|Z| \operatorname{Re}(Z')} \quad // \quad \text{--- (5)} \end{aligned}$$

When  $|Z| = |Z'|$

$$\begin{aligned} \frac{|Z| + Z'}{|Z| - Z'} &= \frac{|Z|^2 - |Z|^2 + 2|Z| \operatorname{Im} Z' i}{|Z|^2 + |Z|^2 - 2|Z| \operatorname{Re} Z'} \\ &= \frac{\operatorname{Im}(Z')i}{|Z| - \operatorname{Re}(Z')} \quad \text{--- (5)} \end{aligned}$$

since  $\operatorname{Im}(Z'), |Z|, \operatorname{Re}(Z') \in \mathbb{R}$  for  $\lambda \in \mathbb{R}$  this can be expressed as

$$\frac{|Z| + Z'}{|Z| - Z'} = \lambda i \quad \text{--- (5)}$$

$\therefore$  This is absolutely imaginary //

04. Using Binomial expansion, prove that  $3^{2n+1} - 3 \cdot 2^n$  is divisible by 21, for all  $n \in \mathbb{Z}^+$

Answer -

$$\begin{aligned}
 3^{2n+1} &= 3 \cdot 3^{2n} \\
 &= 3 \cdot (3^2)^n \\
 &= 3 \cdot 9^n \\
 &= 3 \cdot (2 + 7)^n \quad \text{--- (5)} \\
 &= 3 [{}^n C_0 \cdot 2^n + {}^n C_1 \cdot 2^{(n-1)} \cdot 7 + {}^n C_2 \cdot 2^{(n-2)} \cdot 7^2 + \dots + {}^n C_n \cdot 7^n] \quad \text{--- (5)} \\
 &= 3 \cdot 1 \cdot 2^n + 3 \cdot 7 \underbrace{[{}^n C_1 \cdot 2^{(n-1)} + {}^n C_2 \cdot 2^{(n-2)} \cdot 7 + \dots + 7^{(n-1)}]}_{\text{let } \lambda} \quad \text{--- (5)} \\
 \therefore \text{For all } n \in \mathbb{Z}^+, \lambda \in \mathbb{Z} \quad \text{--- (5)}
 \end{aligned}$$

$$\therefore 3^{(2n+1)} = 3 \cdot 2^n + 21 \lambda$$

$$\therefore 3^{(2n+1)} - 3 \cdot 2^n = 21 \lambda \quad \text{--- (5)}$$

Since  $\lambda$  is an integer, for all  $n \in \mathbb{Z}^+$ ,  $3^{(2n+1)} - 3 \cdot 2^n$  is divisible by 21.

05. Show that  $\lim_{x \rightarrow 0} \left( \frac{x^4}{\tan^2 4x - \sin^2 4x} \right) = \frac{1}{256}$

Answer -

$  \begin{aligned}  &\lim_{x \rightarrow 0} \left( \frac{x^4}{\tan^2 4x - \sin^2 4x} \right) \\  &= \lim_{x \rightarrow 0} \frac{x^4}{(\tan 4x - \sin 4x)(\tan 4x + \sin 4x)} \\  &= \lim_{x \rightarrow 0} \frac{x^4}{\left[ \frac{\sin 4x}{\cos 4x} - \sin 4x \right] \left[ \frac{\sin 4x}{\cos 4x} + \sin 4x \right]} \quad \text{(5)} \\  &= \lim_{x \rightarrow 0} \frac{x^4 \cos^2 4x}{\sin^2 4x [1 - \cos 2(2x)][1 + \cos 4x]} \\  &= \lim_{x \rightarrow 0} \frac{x^4 \cos^2 (4x)}{\sin^2 4x (2 \sin^2 2x)(1 + \cos 4x)} \\  &= \lim_{x \rightarrow 0} \left[ \frac{\cos^2 (4x)}{64 \left( \frac{\sin 4x}{4x} \right) \left( \frac{\sin 4x}{4x} \right) 2 \left( \frac{\sin 2x}{2x} \right) \left( \frac{\sin 2x}{2x} \right) (1 + \cos 4x)} \right] \\  &= \left( \frac{1}{128} \right) \frac{\lim_{x \rightarrow 0} \cos^2 (4x)}{\left[ \lim_{4x \rightarrow 0} \left( \frac{\sin 4x}{4x} \right)^2 \right] \left[ \lim_{2x \rightarrow 0} \left( \frac{\sin 2x}{2x} \right)^2 \right] \left[ \lim_{x \rightarrow 0} (1 + \cos 4x) \right]} \quad \text{(10)} \\  &= \left( \frac{1}{128} \right) \frac{1}{(1)^2 (1)^2 (1+1)} \quad \text{(5)} \\  &= \frac{1}{256} //  \end{aligned}  $	<p>Other method</p> $  \begin{aligned}  &\lim_{x \rightarrow 0} \frac{x^4}{\left[ \frac{\sin^2 4x}{\cos^2 4x} - \sin^2 4x \right]} \quad \text{(5)} \\  &= \lim_{x \rightarrow 0} \frac{x^2 \cos^2 4x}{\left( \frac{\sin^2 4x}{x^2} \right) (1 - \cos^2 4x)} \quad \text{(5)} \\  &= \lim_{x \rightarrow 0} \frac{\cos^2 4x}{16 \left( \frac{\sin 4x}{4x} \right)^2 \left( \frac{\sin 4x}{4x} \right)^2 \cdot 16} \quad \text{(10)} \\  &= \frac{\lim_{x \rightarrow 0} (\cos 4x)}{\left[ \lim_{4x \rightarrow 0} \left( \frac{\sin 4x}{4x} \right) \right]^4 \cdot 256} \quad \text{(5)} \\  &= \frac{1}{256} //  \end{aligned}  $
---	---

06. Let  $S \equiv x^2 + y^2 - 100 = 0$  and  $l \equiv x - 2y + 10 = 0$

Show that the volume generated by rotating the area which is enclosed by  $S = 0$ ,  $l = 0$  and  $x$ -axis, about  $x$ -axis through  $2\pi$  radian is  $480\pi$  cubic units.

Answer -

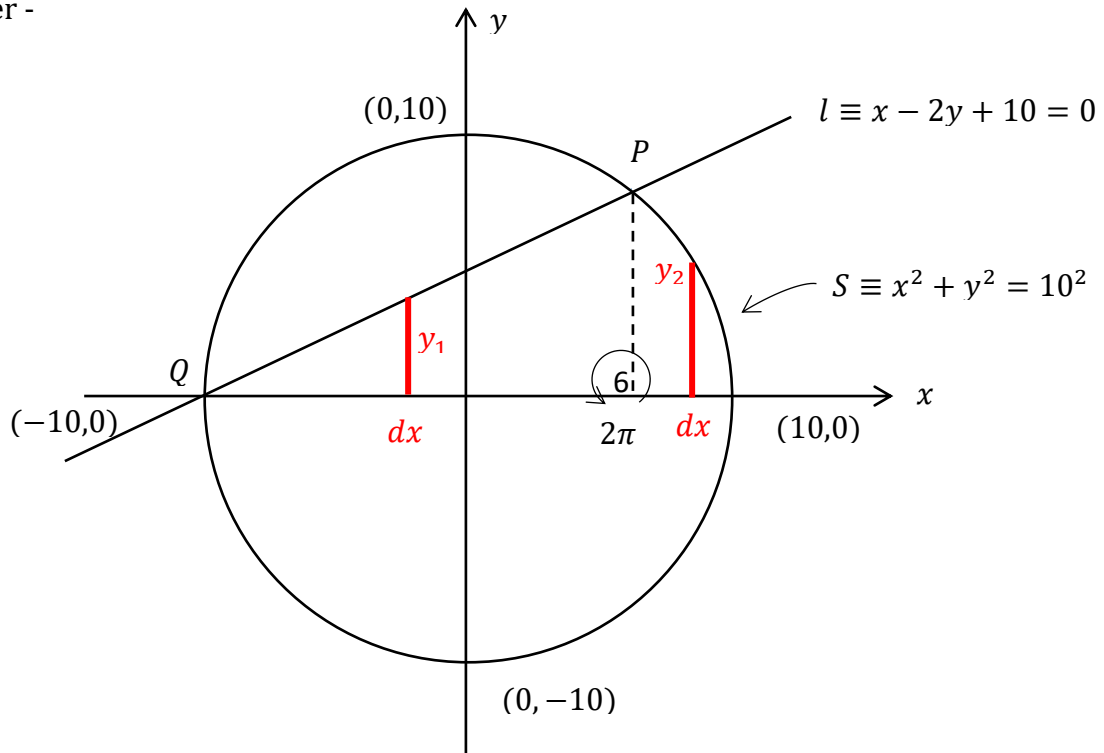

for the points P and Q, by solving  $l = 0$  and  $S = 0$

$$x^2 + y^2 = 10^2 \leftarrow x = (2y - 10)$$

$$(2y - 10)^2 + y^2 = 10^2$$

$$5y^2 - 40y = 0$$

$$y(y - 8) = 0$$

$$\Rightarrow y_1 = 0 \quad \text{and} \quad y_2 = 8$$

$$\text{then } x_1 = -10 \quad x_2 = 6$$

$$P \equiv (6,8), \quad Q \equiv (-10,0) \quad \text{--- } \textcircled{5}$$

Volume,

$$\begin{aligned}
 \therefore V &= \int_{-10}^6 \pi y_1^2 dx + \int_6^{10} \pi y_2^2 dx && \text{--- (5)} \\
 &= \pi \int_{-10}^6 \left(\frac{x+10}{2}\right)^2 dx + \pi \int_6^{10} (100-x^2) dx && \text{--- (5)} \\
 &= \frac{\pi}{4} \left[ \frac{x^3}{3} + 20 \frac{x^2}{2} + 100x \right]_{-10}^6 + \pi \left[ 100x - \frac{x^3}{3} \right]_6^{10} && \text{--- (5)} \\
 &= \frac{\pi}{4} \left[ (72 + 360 + 600) - \left( \frac{-1000}{3} + 1000 - 1000 \right) \right] + \pi \left[ \left( 1000 - \frac{1000}{3} \right) - (600 - 72) \right] \\
 &= \frac{\pi}{4} \left( 1032 + \frac{1000}{3} \right) + \pi \left( \frac{-1000}{3} + 472 \right) && \text{--- (5)} \\
 &= \frac{\pi}{4} \cdot \frac{4096}{3} + \pi \frac{416}{3} = \pi \frac{1024}{3} + \pi \frac{416}{3} \\
 &= \frac{\pi}{3} 1440 = 480\pi \text{ cubic units}
 \end{aligned}$$

07. When  $\theta$  is a parameter,  $0 < \theta < \pi/2$ , a point on a curve C is given by  $x = a \sec \theta$  &  $y = b \tan \theta$ , parametrically, where a & b are constants.

Obtain the equation of the curve C as  $\frac{x^2}{a^2} + \frac{y^2}{b^2} = 1$

Prove that the equation of the tangent drawn to the curve C at the point P on the curve when  $\theta = \pi/6$  is,  $2bx - ay = \sqrt{3}ab$ .

Answer -

$$\begin{aligned}
 x &= a \sec \theta && y = b \tan \theta \\
 \frac{x}{a} &= \sec \theta && \frac{y}{b} = \tan \theta \\
 \therefore \frac{x^2}{a^2} - \frac{y^2}{b^2} &= \sec^2 \theta - \tan^2 \theta && \text{--- (5)} \\
 \therefore \frac{x^2}{a^2} - \frac{y^2}{b^2} &= 1 //
 \end{aligned}$$

$$\frac{dx}{d\theta} = a \sec \theta \tan \theta \quad \text{and} \quad \frac{dy}{d\theta} = b \sec^2 \theta \quad \text{—————} \textcircled{5}$$

$$\frac{dy}{dx} = \frac{dy}{d\theta} \cdot \frac{d\theta}{dx} = \frac{dy}{d\theta} \cdot \frac{1}{\left(\frac{dx}{d\theta}\right)}, \quad \text{when} \quad \frac{dx}{d\theta} \neq 0$$

$$\therefore \frac{dy}{dx} = \frac{b \sec^2 \theta}{a \sec \theta \cdot \tan \theta} = \frac{b \sec \theta}{a \tan \theta}$$

$$\therefore \left(\frac{dy}{d\theta}\right)_{P(\theta=\pi/6)} = \frac{b \sec(\pi/6)}{a \tan(\pi/6)} = \frac{b(2/\sqrt{3})}{a(1/\sqrt{3})} = \frac{2b}{a} \quad \text{—————} \textcircled{5}$$

∴ The equation of the tangent drawn to the curve C at P, is

$$y - y' = m(x - x')$$

$$y - b \tan \theta = \frac{2b}{a}(x - a \sec \theta) \quad \text{—————} \textcircled{5}$$

$$y - b \cdot \frac{1}{\sqrt{3}} = \frac{2b}{a} \left(x - a \cdot \frac{2}{\sqrt{3}}\right) \quad \text{—————} \textcircled{5}$$

$$ay - \frac{ab}{\sqrt{3}} = 2bx - \frac{4ab}{\sqrt{3}}$$

$$ay = 2bx - \sqrt{3}ab \Rightarrow 2bx - ay = \sqrt{3}ab //$$

08. Prove that the area enclosed by the two angle bisectors between  $4x - 3y + 2 = 0$ ,  $4x + 3y - 7 = 0$  and x-axis and y-axis is  $\frac{15}{16}$  square units.

Answer -

Equations of angle bisectors

$$\left(\frac{4x - 3y + 2}{\sqrt{4^2 + 3^2}}\right) = \pm \left(\frac{4x + 3y - 7}{\sqrt{4^2 + 3^2}}\right) \quad \text{—————} \textcircled{5}$$

$$(+) \Rightarrow 4x - 3y + 2 = 4x + 3y - 7$$

$$y = 3/2 // \quad \text{—————} \textcircled{5}$$

$$(-) \Rightarrow 4x - 3y + 2 = -4x - 3y + 7$$

$$x = 5/8 // \quad \text{—————} \textcircled{5}$$



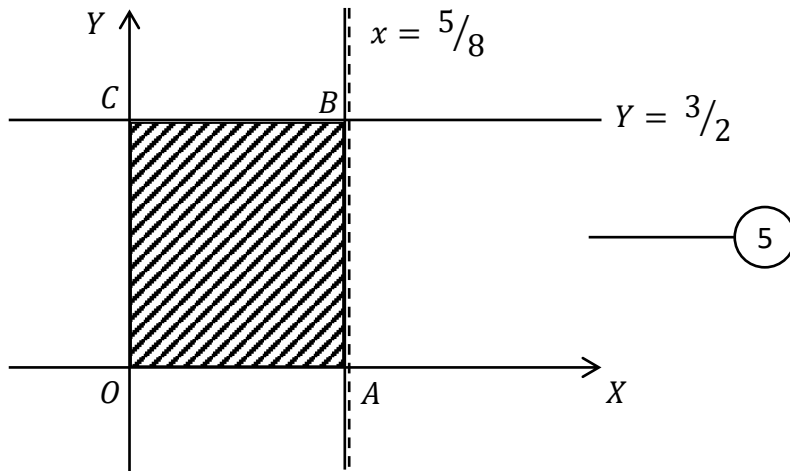

When the area of the shaded region, which is enclosed by two angle bisectors and OX axis and OY axis is S,

$$\begin{aligned}
 S &= (OA)(OC) \\
 &= \left(\frac{5}{8}\right)\left(\frac{3}{2}\right) \quad \text{--- } \textcircled{5} \\
 &= \frac{15}{16} \text{ Square units.}
 \end{aligned}$$

09. The circle  $s' = 0$ , which passes through the two ends of the diameter of  $S \equiv x^2 + y^2 - 6x - 14y + 54 = 0$  which parallel to  $y$ -axis, is also passes through the origin, find the equation of  $S'$ .

Answer -

$$S \equiv x^2 + y^2 - 6x - 14y + 54 = 0$$

$$(x - 3)^2 + (y - 7)^2 = 2^2$$

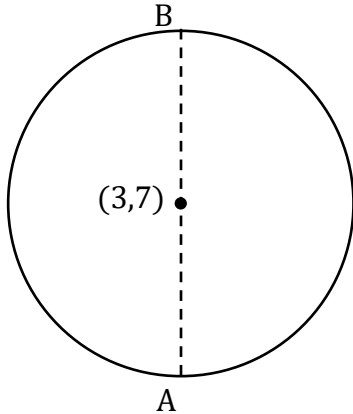

For the points A and B, when  $x=3$  on  $s=0$ ,

$$(3 - 3)^2 + (y - 7)^2 = 2^2$$

$$y - 7 = \pm 2$$

$$\oplus \Rightarrow y = 9$$

$$\ominus \Rightarrow y = 5$$

$$\therefore A \equiv (3,5)$$

$$B \equiv (3,9)$$

5

5

Let the circle which passes through both A & B and the origin,  $S' \equiv x^2 + y^2 + 2gx + 2fy + c = 0$

$$(0,0) \Rightarrow c = 0 //$$

5

$$(3,5) \Rightarrow 3^2 + 5^2 + 2g3 + 2f5 + 0 = 0$$

$$6g + 10f = -34 \text{---} \textcircled{1}$$

$$(3,9) \Rightarrow 3^2 + 9^2 + 2g3 + 2f9 + 0 = 0$$

$$6g + 18f = -90 \text{---} \textcircled{2}$$

$$\textcircled{2} - \textcircled{1} \rightarrow f = -7$$

5

$$\therefore \textcircled{1} \rightarrow g = 6$$

5

$$\therefore S' \equiv x^2 + y^2 + 2(6)x + 2(-7)y + (0) = 0$$

$$x^2 + y^2 + 12x - 14y = 0 //$$

10. Using the identity  $\sin^2\theta + \cos^2\theta = 1$ , Prove that  $\operatorname{Cosec}^2\theta = 1 + \cot^2\theta$  When  $n \in \mathbb{Z}$  and  $\theta \neq n\pi$ . Further, when  $\operatorname{Cosec}\theta - \cot\theta = \frac{1}{7}$  deduce that  $\operatorname{Cosec}\theta + \cot\theta = 7$  and Hence obtain that  $\sin\theta = \frac{7}{25}$ .

Answer -

$$\sin^2\theta + \cos^2\theta = 1$$

$$\therefore \frac{\sin^2\theta}{\sin^2\theta} + \frac{\cos^2\theta}{\sin^2\theta} = \frac{1}{\sin^2\theta}, \quad (\theta \neq n\pi \Rightarrow \sin\theta \neq 0)$$

$$1 + \left(\frac{\cos\theta}{\sin\theta}\right)^2 = \left(\frac{1}{\sin\theta}\right)^2$$

$$1 + \cot^2\theta = \operatorname{Cosec}^2\theta // \quad \text{————— (5)}$$

$$\Rightarrow \operatorname{Cosec}^2\theta - \cot^2\theta = 1$$

$$(\operatorname{Cosec}\theta - \cot\theta)(\operatorname{Cosec}\theta + \cot\theta) = 1 \quad \text{————— (5)}$$

$$\left(\frac{1}{7}\right)(\operatorname{Cosec}\theta + \cot\theta) = 1 \quad \text{————— (5)}$$

$$\therefore \operatorname{Cosec}\theta + \cot\theta = 7 - \textcircled{1}$$

$$\operatorname{Cosec}\theta - \cot\theta = \frac{1}{7} - \textcircled{2}$$

$$\textcircled{1} + \textcircled{2} \Rightarrow 2\operatorname{Cosec}\theta = 7 + \frac{1}{7} \quad \text{————— (5)}$$

$$\operatorname{Cosec}\theta = \frac{25}{7}$$

$$\Rightarrow \sin\theta = \frac{7}{25} // \quad \text{————— (5)}$$

**Part B**

11. (a). Let,  $f(x) \equiv lx^2 + (n - 1)x + 1$  and  $g(x) \equiv (m + 1)x^2 - nx - 1$  There exist a common root as  $x = (\alpha + 1)$  for both  $f(x) = 0$  and  $g(x) = 0$ . The other roots of  $f(x) = 0$  and  $g(x) = 0$  are  $\beta$  and  $\gamma$  respectively. Also  $\alpha \neq -1$  and  $(l + m) \neq -1$ .

Obtain the results.

(i).  $\alpha = \frac{-(l+m)}{l+m+1}$

(ii).  $\beta - \gamma = \frac{(1+m)(1-n)-ln}{l(m+1)}$

(iii).  $l\beta + (m + 1)\gamma = 0$

Write down the determinants  $\Delta f$  and  $\Delta g$  of  $f(x) = 0$  and  $g(x) = 0$  respectively and prove that  $\Delta f + \Delta g = 2n^2 + 4m - 4l - 2n + 5$

If all  $(\alpha + 1), \beta$  and  $\gamma$  are real and distinct, deduce that,  $8(l - m) < 9$

- (b). Let  $P(x) \equiv x^4 + x^3 - px^2 + p^2x - 1$

Prove that there exist no factors as  $(x + 1)$  or as  $(x^2 + 1)$  for  $P(x)$ .

But, if  $(x + 1)$  is a factor for " $P(x) + 1$ " then show that  $P(x) + 1$  can be expressed as,  $x(x + 1)(x^2 + 1)$  or as  $x^3(x + 1)$ .

As  $(\alpha + 1)$  is a root of  $f(x) = 0$   $f(\alpha + 1) = 0$  \_\_\_\_\_ (5)  
 $l(\alpha + 1)^2 + (n - 1)(\alpha + 1) + 1 = 0$  -① \_\_\_\_\_ (5)

As  $(\alpha + 1)$  is a root of  $g(x) = 0$   $g(\alpha + 1) = 0$  \_\_\_\_\_ (5)  
 $(m + 1)(\alpha + 1)^2 - n(\alpha + 1) - 1 = 0$  -② \_\_\_\_\_ (5)

① + ②  $\Rightarrow (l + m + 1)(\alpha + 1)^2 - (\alpha + 1) = 0$

$\alpha \neq -1 \Rightarrow (\alpha + 1) \neq 0 \Rightarrow (l + m + 1)(\alpha + 1) - 1 = 0$  \_\_\_\_\_ (5)

$\therefore \alpha + 1 = \frac{1}{l + m + 1} \Rightarrow \alpha = \frac{1}{l + m + 1} - 1$  \_\_\_\_\_ (5)

$\alpha = \frac{-(l + m)}{(l + m + 1)} //$

As  $(\alpha + 1)$  and  $\beta$  are the roots of  $f(x) \equiv lx^2 + (n - 1)x + 1 = 0$  by considering the addition of roots  $\rightarrow \alpha + \beta + 1 = \frac{1-n}{l}$  — (3) ————— (5)

Also  $(\alpha + 1)$  and  $\gamma$  are the root of

$$g(x) \equiv (m + 1)x^2 - nx - 1 = 0 \quad \alpha + \gamma + 1 = \frac{n}{m+1} \text{ — (4) ————— (5)}$$

$$\begin{aligned} \text{(3)} - \text{(4)} &\Rightarrow \beta - \gamma = \frac{1-n}{l} - \frac{n}{m+1} \text{ ————— (5)} \\ &= \frac{(1+m)(1-n) - ln}{l(m+1)} // \end{aligned}$$

Similarly, by considering the product of roots of  $f(x) = 0$  and  $g(x) = 0$

$$f(x) \rightarrow (\alpha + 1)\beta = \frac{1}{l} \text{ — (5) ————— (5)}$$

$$g(x) \rightarrow (\alpha + 1)\gamma = \frac{-1}{m+1} \text{ — (6) ————— (5)}$$

$$\frac{\text{(5)}}{\text{(6)}} \Rightarrow \frac{(\alpha + 1)\beta}{(\alpha + 1)\gamma} = \frac{1/l}{-1/(m+1)} \Rightarrow \frac{\beta}{\gamma} = \frac{-(m+1)}{l} \text{ ————— (5)}$$

$$\therefore l\beta + (m + 1)\gamma = 0 //$$

Discriminant of  $f(x) = 0$

$$\begin{aligned} \Delta f &= (n - 1)^2 - 4l \\ &= n^2 - 2n + 1 - 4l \text{ — (7) ————— (5)} \end{aligned}$$

Discriminant of  $g(x) = 0$

$$\begin{aligned} \Delta g &= n^2 + 4(m + 1) \\ &= n^2 + 4m + 4 \text{ — (8) ————— (5)} \end{aligned}$$

$$\text{(7)} + \text{(8)} \Rightarrow \Delta f + \Delta g = 2n^2 - 2n + 5 + 4(m - l) // \text{ ————— (5)}$$

As all  $(\alpha + 1)$ ,  $\beta$  and  $\gamma$  are real and distinct

$$\Delta f > 0 \text{ and } \Delta g > 0 \text{ ————— (5)}$$

$$\therefore \Delta f + \Delta g > 0$$

PAPERMASTER.LK



$$\therefore 2n^2 - 2n + 5 + 4(m - l) > 0 \quad \text{—————} \textcircled{5}$$

Let  $P(n) = 2n^2 - 2n + 5$

$$\begin{aligned} P(n) &= 2\left[n^2 - n + \frac{5}{2}\right] \\ &= 2\left[\left(n - \frac{1}{2}\right)^2 + \frac{5}{2} - \frac{1}{4}\right] \\ &= 2\left[\left(n - \frac{1}{2}\right)^2 + \frac{9}{4}\right] \end{aligned}$$

When  $n = \frac{1}{2}$   $P(n)$  has its minimum value. It is  $[P(n)] \min = \frac{9}{2}$ . —————  $\textcircled{5}$

$$\therefore \text{For the minimum } P(n) \text{ value } \Delta f + \Delta g > 0 \quad \text{—————} \textcircled{5}$$

$$\therefore \frac{9}{2} + 4(m - l) > 0$$

$$\Rightarrow \frac{9}{2} > 4(l - m) \quad \text{—————} \textcircled{5}$$

$$\Rightarrow 8(l - m) < 9 //$$

(b) Part

$$P(x) \equiv x^4 + x^3 - px^2 + p^2x - 1$$

If  $(x + 1)$  is a factor of  $P(x)$ , then  $x = -1$  is a root.

$$P(-1) = (-1)^4 + (-1)^3 - p(-1)^2 + p^2(-1) - 1 = -(p^2 + p)$$

For any  $p \in \mathbb{R}$  this  $P(-1) = 0$ , ( $\therefore \Delta < 0$ )

$$\therefore x = -1 \text{ is not a root} \rightarrow (x + 1) \text{ is not a factor.} \quad \text{—————} \textcircled{10}$$

$$\begin{array}{r} x^2 + 1 \overline{) \begin{array}{r} x^4 + x^3 - px^2 + p^2x - 1 \\ \underline{x^4 \phantom{+ x^3} + x^2} \\ x^3 - (p+1)x^2 + p^2x - 1 \\ \underline{x^3 \phantom{- (p+1)x^2} + x} \\ -(p+1)x^2 + (p^2-1)x - 1 \\ \underline{-(p+1)x^2 \phantom{+ (p^2-1)x} - (p+1)} \\ (p^2-1)x + p \end{array}} \end{array}$$

There is no single  $p$  value such that above remainder is zero.

$$\therefore (x^2 + 1) \text{ is not a factor of } p(x). \quad \text{—————} \textcircled{10}$$

Let  $P(x) + 1 = H(x)$

Then  $H(x) \equiv x^4 + x^3 - px^2 + p^2x$

As  $(x + 1)$  is a factor of  $p(x) + 1 = H(x)$

$$\begin{aligned}
 H(-1) = 0 & \quad \text{---} \quad \textcircled{5} \quad \text{---} \quad \textcircled{5} \\
 \Rightarrow (-1)^4 + (-1)^3 - p(-1)^2 + p^2(-1) = 0 \\
 1 - 1 - p - p^2 = 0 \\
 p(p+1) = 0
 \end{aligned}$$

$$\Rightarrow p = 0 \text{ or } p = -1 \quad \text{---} \quad \textcircled{5} \quad \text{---} \quad \textcircled{5}$$

When  $p = 0$  ; -

$$\begin{aligned}
 P(x)+1 = H(x) = x^4 + x^3 & \quad \text{---} \quad \textcircled{5} \\
 = x^3(x + 1) //
 \end{aligned}$$

When  $p = -1$  ; -

$$\begin{aligned}
 P(x)+1 = H(x) = x^4 + x^3 + x^2 + x & \quad \text{---} \quad \textcircled{5} \\
 = x^3(x + 1) + x(x + 1) \\
 = (x + 1)(x^3 + x) \\
 = x(x + 1)(x^2 + 1) //
 \end{aligned}$$

12. (a). A selected pool of boys and girls from two schools A & B are given below.

	boys	girls
School A	3	4
School B	7	5

A committee of 5 members has to be appointed from the above set of students.

Find the number of different committees that can be appointed under each condition.

- (i). Any five of the pool,
- (ii). Any five including both male and female,
- (iii). Any five including both schools A and B,
- (iv). Any five from both schools and also both male and female from each school.

(b). Let  $\lambda \geq 0$  and  $r \in \mathbb{Z}^+$

Show that  $\frac{2}{r + \lambda} - \frac{2}{r + \lambda - 2} = \frac{-4}{(r + \lambda)(r + \lambda - 2)}$

Hence find  $V_r$  such that  $U_r = V_r - V_{(r+2)}$

Where  $U_r = \frac{2}{(r + \lambda)(r + \lambda - 2)}$

Prove that  $\sum_{r=1}^n U_r = \frac{2\lambda - 1}{\lambda(\lambda - 1)} - \left[ \frac{2(\lambda + n) - 1}{(n + \lambda)(n + \lambda - 1)} \right]$

Show that the finite series  $\sum_{r=1}^n U_r$  is convergence & find the sum of that infinite series

- Using a suitable value for  $\lambda$ , deduce that.

$$\sum_{r=1}^{\infty} \frac{2}{(r + 1)(r + 3)} = \frac{5}{6}$$

Answer - (a).

A	
G	B
3	4

7

B	
G	B
5	7

12

Total = 19

(i). When any five from the pool,

number of different committers  $= {}^{19}C_5$  ————— (10)

$$= \frac{19 \cdot 18 \cdot 17 \cdot 16 \cdot 15 \cdot 14}{5 \cdot 4 \cdot 3 \cdot 2 \cdot 1 \cdot 14}$$

$$= 19 \cdot 18 \cdot 17 \cdot 2$$

$$= 11628$$
 ————— (5)

(ii). When any five including both male and female

G - 8	B - 11	
5	0	
4	1	→ ${}^8C_4 \times {}^{11}C_1 = 70 \times 11 = 770$
3	2	→ ${}^8C_3 \times {}^{11}C_2 = 56 \times 55 = 3080$
2	3	→ ${}^8C_2 \times {}^{11}C_3 = 28 \times 165 = 4620$
1	4	→ ${}^8C_1 \times {}^{11}C_4 = 8 \times 330 = 2640$
0	5	

$$\begin{array}{r} 770 \\ 3080 \\ 4620 \\ 2640 \\ \hline 11110 \end{array}$$

5  
5  
5  
5  
5

(iii). When any five including both schools A and B,

A - 7	B - 12	
5	0	
4	1	→ ${}^7C_4 \times {}^{12}C_1 = 35 \times 12 = 420$
3	2	→ ${}^7C_3 \times {}^{12}C_2 = 35 \times 66 = 2310$
2	3	→ ${}^7C_2 \times {}^{12}C_3 = 21 \times 220 = 4620$
1	4	→ ${}^7C_1 \times {}^{12}C_4 = 7 \times 495 = 3465$
0	5	

$$\begin{array}{r} 420 \\ 2310 \\ 4620 \\ 3465 \\ \hline 10815 \end{array}$$

10 } 5 for two steps  
5

(iv). When any five from both schools A and B and both male and female from each school.

A		B		
G-3	B-4	G-5	B-7	
1+1	1	1	1	→ ${}^3C_2 \times {}^4C_1 \times {}^5C_1 \times {}^7C_1 = 3.4.5.7 = 420$
1	1+1	1	1	→ ${}^3C_1 \times {}^4C_2 \times {}^5C_1 \times {}^7C_1 = 3.6.5.7 = 630$
1	1	1+1	1	→ ${}^3C_1 \times {}^4C_1 \times {}^5C_2 \times {}^7C_1 = 3.4.10.7 = 840$
1	1	1	1+1	→ ${}^3C_1 \times {}^4C_1 \times {}^5C_1 \times {}^7C_2 = 3.4.5.21 = 1260$

$$\begin{array}{r} 420 \\ 630 \\ 840 \\ 1260 \\ \hline 3150 \end{array}$$

5 for two steps } 10  
5

(b).

$$\frac{2}{(r+\lambda)} - \frac{2}{(r+\lambda-2)} = 2 \left[ \frac{(r+\lambda-2) - (r+\lambda)}{(r+\lambda)(r+\lambda-2)} \right] \quad \text{————— } 5$$

$$= \frac{-4}{(r+\lambda)(r+\lambda-2)} //$$

$$\therefore \text{As } \frac{-4}{(r+\lambda)(r+\lambda-2)} = \frac{2}{(r+\lambda)} - \frac{2}{(r+\lambda-2)}$$

$$\frac{2}{(r+\lambda)(r+\lambda-2)} = \frac{1}{(r+\lambda-2)} - \frac{1}{(r+\lambda)}$$

PAPERMASTER.LK



$$\therefore Ur = \frac{1}{(r + \lambda - 2)} - \frac{1}{(r + \lambda)} \quad \text{————— (5)}$$

Now let  $\frac{1}{r + \lambda - 2} = Vr$  ————— (5)

$$\therefore \frac{1}{r + \lambda} = V_{(r+2)} \quad \text{————— (5)}$$

$\therefore$  Then  $Ur = Vr - V_{(r+2)}$  ————— (5)

$$\begin{array}{rcll} r=1 & \rightarrow & U_1 & = & V_1 & - & V_3 & \left. \vphantom{\begin{array}{l} r=1 \\ r=2 \\ r=3 \\ \vdots \\ \vdots \\ \vdots \\ r=(n-2) \\ r=(n-1) \\ r=n \end{array}} \right\} & \text{————— (5)} \\ r=2 & \rightarrow & U_2 & = & V_2 & - & V_4 & \\ r=3 & \rightarrow & U_3 & = & V_3 & - & V_5 & \\ \vdots & & \vdots & & \vdots & & \vdots & \\ \vdots & & \vdots & & \vdots & & \vdots & \\ \vdots & & \vdots & & \vdots & & \vdots & \\ r=(n-2) & \rightarrow & U_{(n-2)} & = & V_{(n-2)} & - & V_n & \\ r=(n-1) & \rightarrow & U_{(n-1)} & = & V_{(n-1)} & - & V_{(n+1)} & \left. \vphantom{\begin{array}{l} r=1 \\ r=2 \\ r=3 \\ \vdots \\ \vdots \\ \vdots \\ r=(n-2) \\ r=(n-1) \\ r=n \end{array}} \right\} & \text{————— (5)} \\ r=n & \rightarrow & U_n & = & V_n & - & V_{(n+2)} & \end{array}$$

(+)

$$U_1 + U_2 + \dots + U_{(n-1)} + U_n = V_1 + V_2 - V_{(n+1)} - V_{n+2} \quad \text{————— (5)}$$

$$\therefore \sum_{r=1}^n Ur = \frac{1}{\lambda - 1} + \frac{1}{\lambda} - \left[ \frac{1}{(n + \lambda - 1)} + \frac{1}{(n + \lambda)} \right] \quad \text{————— (5)}$$

$$\begin{aligned} \therefore \sum_{r=1}^n Ur &= \left[ \frac{\lambda + \lambda - 1}{\lambda(\lambda - 1)} \right] - \left[ \frac{(n + \lambda) + (n + \lambda - 1)}{(n + \lambda)(n + \lambda - 1)} \right] \quad \text{————— (5)} \\ &= \frac{2\lambda - 1}{\lambda(\lambda - 1)} - \left[ \frac{2(n + \lambda) - 1}{(n + \lambda)(n + \lambda - 1)} \right] // \end{aligned}$$

Now, to prove that the series is convergence

Consider  $\lim_{n \rightarrow \infty}$

$$\text{Then } \lim_{n \rightarrow \infty} \sum_{r=1}^n Ur = \lim_{n \rightarrow \infty} \left\{ \left[ \frac{2\lambda - 1}{\lambda(\lambda - 1)} \right] - \left[ \frac{2(n + \lambda) - 1}{(n + \lambda)(n + \lambda - 1)} \right] \right\}$$



13. (a).  $P = \begin{pmatrix} 1 & 0 \\ 0 & \lambda \end{pmatrix}$ ,  $Q = \begin{pmatrix} -2 & \lambda \\ 3 & 4 \\ 0 & -1 \end{pmatrix}$  and  $R = \begin{pmatrix} \mu - 1 & 0 \\ -3 & \mu - 1 \end{pmatrix}$  are three matrices

such that,  $P^T Q = R$   $\lambda, \mu \in \mathbb{R}$

- Show that  $\lambda = \mu = -1$
- Write down corresponding  $R$

By considering that  $R$  and the matrix  $A = \begin{pmatrix} -1/2 & 0 \\ 3/4 & -1/2 \end{pmatrix}$

- Prove that  $A = R^{-1}$

When  $S = \begin{pmatrix} 0 & 0 \\ 3 & 0 \end{pmatrix}$

- Prove that (i).  $(R+I)S = -S$  and
- (ii).  $R+2I+S = 0$  and, hence deduce that,
- $(R+2I)(S-I) = S$

Where  $I$  is the 2<sup>nd</sup> order identity matrix.

(b). Let  $Z_1 = -1+2i$  and  $Z_2 = 2 + i$

Find  $\frac{Z_1}{Z_2}$  and deduce that  $\frac{Z_2}{Z_1}$ . Hence obtain

$\frac{Z_1 + Z_2}{Z_1}$  and  $\frac{Z_1 + Z_2}{Z_2}$  and deduce that

(i).  $\frac{Z_1 + Z_2}{Z_2} + \frac{Z_1 + Z_2}{Z_1} = 2$  and

(ii).  $\frac{(Z_1)^2 - (Z_2)^2}{Z_1 Z_2} = 2i$

$Z_A$  is a complex number such that,

$|Z_A| = 4$  and  $Arg(Z_A) = \pi/6$  and  $Z_B = iZ_A$

Mark  $Z_A$  and  $Z_B$  on **Argand plane**.

Obtain the position of  $Z_C = (Z_A + Z_B)$ .

Deduce that,  $Tan(\pi/12) = \frac{\sqrt{3}-1}{\sqrt{3}+1}$

When O, A, B and C are the points on argand plane representing  $(o + oi)$ ,  $Z_A, Z_B$  and  $(Z_A + Z_B)$  respectively. Show that the area enclosed by the lines AB and BC and the arc of the circle passing through both A and B with the centre O, is  $4(4 - \pi)$  square units.



Answer -

(a) As  $P^T Q = R$

$$\begin{pmatrix} 1 & 0 & \lambda \\ 0 & \lambda & -2 \end{pmatrix} \begin{pmatrix} -2 & \lambda \\ 3 & 4 \\ 0 & -1 \end{pmatrix} = \begin{pmatrix} \mu - 1 & 0 \\ -3 & \mu - 1 \end{pmatrix} \quad \text{--- (5)}$$

$$\begin{pmatrix} -2 & 0 \\ 3\lambda & 4\lambda + 2 \end{pmatrix} = \begin{pmatrix} \mu - 1 & 0 \\ -3 & \mu - 1 \end{pmatrix} \quad \text{--- (5)}$$

$$\Rightarrow \begin{matrix} -2 = \mu - 1 \\ \mu = -1 // \end{matrix}, \quad 0 = 0 //, \quad \begin{matrix} 3\lambda = -3 \\ \lambda = -1 // \end{matrix}, \quad \begin{matrix} 4\lambda + 2 = \mu - 1 \\ -2 = -2 // \end{matrix} \quad \text{--- (5)}$$

only for all four equations

$$\therefore \text{Relevant } R = \begin{pmatrix} -2 & 0 \\ -3 & -2 \end{pmatrix}_{(2 \times 2)} // \quad \text{--- (5)}$$

When  $A = \begin{pmatrix} -1/2 & 0 \\ 3/4 & -1/2 \end{pmatrix}$  consider the product,

$$RA = \begin{pmatrix} -2 & 0 \\ -3 & -2 \end{pmatrix} \begin{pmatrix} -1/2 & 0 \\ 3/4 & -1/2 \end{pmatrix} \quad \text{--- (5)}$$

$$= \begin{pmatrix} 1 & 0 \\ 0 & 1 \end{pmatrix} \quad \text{--- (5)}$$

$$\Rightarrow RA = I$$

$$\left. \begin{array}{l} \therefore R^{-1}RA = R^{-1}I \\ IA = R^{-1} \\ A = R^{-1} // \end{array} \right\} \quad \text{--- (5)}$$

(i). When  $S = \begin{pmatrix} 0 & 0 \\ 3 & 0 \end{pmatrix}$  and  $I = \begin{pmatrix} 1 & 0 \\ 0 & 1 \end{pmatrix}$

$$(R + I)S = \left[ \begin{pmatrix} -2 & 0 \\ -3 & -2 \end{pmatrix} + \begin{pmatrix} 1 & 0 \\ 0 & 1 \end{pmatrix} \right] \begin{pmatrix} 0 & 0 \\ 3 & 0 \end{pmatrix} \quad \text{--- (5)}$$

$$= \begin{pmatrix} -1 & 0 \\ -3 & -1 \end{pmatrix} \begin{pmatrix} 0 & 0 \\ 3 & 0 \end{pmatrix}$$

$$= \begin{pmatrix} 0 & 0 \\ -3 & 0 \end{pmatrix} \quad \text{--- (5)}$$

$$\therefore (R + I)S = -S //$$

$$\begin{aligned}
 \text{(ii). } R + 2I + S &= \begin{pmatrix} -2 & 0 \\ -3 & -2 \end{pmatrix} + 2 \begin{pmatrix} 1 & 0 \\ 0 & 1 \end{pmatrix} + \begin{pmatrix} 0 & 0 \\ 3 & 0 \end{pmatrix} \\
 &= \begin{pmatrix} -2 & 0 \\ -3 & -2 \end{pmatrix} + \begin{pmatrix} 2 & 0 \\ 0 & 2 \end{pmatrix} + \begin{pmatrix} 0 & 0 \\ 3 & 0 \end{pmatrix} \quad \text{————— (5)} \\
 &= \begin{pmatrix} 0 & 0 \\ 0 & 0 \end{pmatrix} \quad \text{————— (5)}
 \end{aligned}$$

$$\therefore R + 2I + S = 0 //$$

$$\begin{aligned}
 \text{(i)} \Rightarrow (R + I)S &= -S \\
 \Rightarrow (R + I)S + S &= 0 \\
 \Rightarrow (R + I + I)S &= 0 \\
 \Rightarrow (R + 2I)S &= 0
 \end{aligned}$$

$$\text{As (i) = (ii)}$$

$$\begin{aligned}
 (R + 2I)S &= R + 2I + S \quad \text{————— (5)} \\
 \Rightarrow (R + 2I)S - (R + 2I) &= S \quad \text{————— (5)} \\
 \Rightarrow (R + 2I)(S - I) &= S
 \end{aligned}$$

$$\text{(b). } Z_1 = -1 + 2i$$

$$Z_2 = 2 + i$$

$$\begin{aligned}
 \bullet \quad \frac{Z_1}{Z_2} &= \frac{-1 + 2i}{2 + i} \\
 &= \frac{(-1 + 2i)(2 - i)}{(2 + i)(2 - i)} \quad \text{————— (5)} \\
 &= \frac{-2 + i + 4i - 2(i^2)}{2^2 - (i)^2} = \frac{0 + 5i}{5} \\
 &= i // \quad \text{————— (5)}
 \end{aligned}$$

$$\begin{aligned}
 \bullet \quad \frac{Z_2}{Z_1} &= \frac{1}{\left(\frac{Z_1}{Z_2}\right)} = \frac{1}{i} = \frac{1(-i)}{i(-i)} \quad \text{————— (5)} \\
 &= \frac{-i}{-(i)^2} = -i // \quad \text{————— (5)}
 \end{aligned}$$

- $\frac{z_1 + z_2}{z_1} = \frac{z_1}{z_1} + \frac{z_2}{z_1} = 1 + (-i) = 1 - i //$  (5)

- $\frac{z_1 + z_2}{z_2} = \frac{z_1}{z_2} + \frac{z_2}{z_2} = i + 1 = 1 + i //$  (5)

- $\therefore \frac{z_1 + z_2}{z_2} + \frac{z_1 + z_2}{z_1} = (1 + i) + (1 - i) = 2 //$  (5)

- $\frac{(z_1)^2 - (z_2)^2}{z_1 z_2} = \frac{(z_1 + z_2)(z_1 - z_2)}{z_1 z_2}$   
 $= \frac{(z_1 + z_2)z_1}{z_1 z_2} - \frac{(z_1 + z_2)z_2}{z_1 z_2}$  (5)

- $= \left(\frac{z_1 + z_2}{z_2}\right) - \left(\frac{z_1 + z_2}{z_1}\right)$  (5)

- $= (1 + i) - (1 - i)$

- $= 2i //$

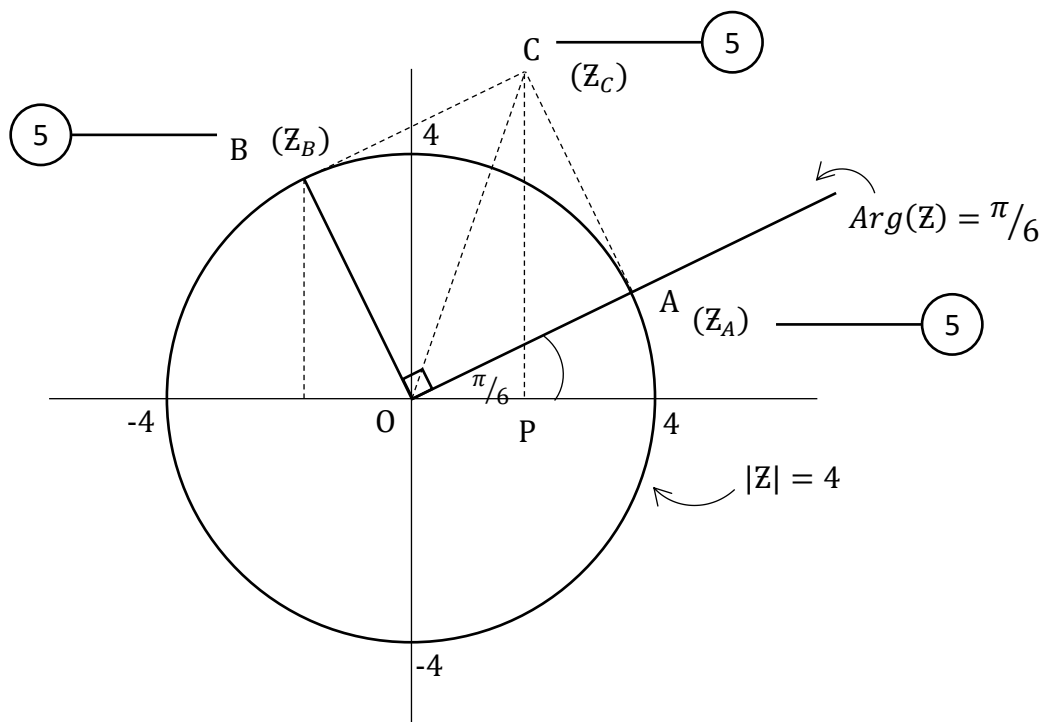

$$z_B = i z_A = z_A i$$

$$= z_A [\cos(\pi/2) + i \sin(\pi/2)]$$

PAPERMASTER.LK

If  $Z_1$  and  $Z_2$  are any two complex numbers

As  $|Z_1 Z_2| = |Z_1||Z_2|$  and

$$\text{Arg}(Z_1 Z_2) = \text{Arg}(Z_1) + \text{Arg}(Z_2)$$

$Z_B$  is the complex number relevant to the point that the complex number  $Z_A$  is multiplied by a complex number having,

$$\text{Argument} = \pi/2 \quad \text{and modulus} = 1$$

$\therefore Z_B$  must be at the point as given in the diagram.

Now by considering the geometric characteristics of the addition of two complex number, the position of the point C can be obtained by completing the square OACB where OA and OB are two adjacent sides.

$\therefore Z_C = (Z_A + Z_B)$  is on the point C on **argend plane**.

Now consider the diagonal

$$\text{Then } \widehat{AOC} = \frac{\pi/2}{2} = \pi/4$$

$$\text{Also, as } \widehat{XOA} = \text{Arg}(Z_A) = \pi/6$$

$$\widehat{XOC} = \frac{\pi}{6} + \frac{\pi}{4} = \frac{5\pi}{12}, (= 75^\circ)$$

$$\therefore \widehat{YOC} = \frac{\pi}{2} - \frac{5\pi}{12} = \frac{\pi}{12}, (= 15^\circ)$$

Further  $\widehat{YOC} = \widehat{OCP}$  (Alternate angles)

Also

$$OP = \text{Re}(Z_C)$$

$$PR = \text{Im}(Z_C)$$

$$\therefore \text{Tan}(\pi/12) = \text{Tan}(\widehat{OCP})$$

$$= \frac{OP}{PC}$$

$$= \frac{\text{Re}(Z_C)}{\text{Im}(Z_C)}$$

5

$$\begin{aligned}
Z_C &= Z_A + Z_B \\
&= [4\cos(\pi/6) + i 4\sin(\pi/6)] + [-4\cos(\pi/3) + i 4\sin(\pi/3)] \\
&= (2\sqrt{3} + 2i) + (-2 + 2\sqrt{3}i) \\
&= 2(\sqrt{3} - 1) + i 2(\sqrt{3} + 1)
\end{aligned}$$

$$\Rightarrow \operatorname{Re}(Z_C) = 2(\sqrt{3} - 1) \quad \text{—————} \textcircled{5}$$

$$\operatorname{Im}(Z_C) = 2(\sqrt{3} + 1) \quad \text{—————} \textcircled{5}$$

$$\begin{aligned}
\therefore \tan(\pi/12) &= \frac{\operatorname{Re}(Z_C)}{\operatorname{Im}(Z_C)} = \frac{2(\sqrt{3} - 1)}{2(\sqrt{3} + 1)} \\
&= \left( \frac{(\sqrt{3} - 1)}{(\sqrt{3} + 1)} \right) //
\end{aligned}$$

Now, in the diagram,

- The area enclosed by - arc AB, line AC and line BC (let S)

$$S = (\text{area of square } AOBC) - \frac{1}{4} (\text{area of a circle with } r = 4) \quad \text{—————} \textcircled{5}$$

$$= (4 \cdot 4) - \frac{1}{4} \pi(4)^2$$

$$= 16 \left( 1 - \frac{\pi}{4} \right) \quad \text{—————} \textcircled{5}$$

$$= 4(4 - \pi) \text{ square units } //$$

14. (a) For  $x \in \mathbb{R} - \{2\}$  Show that the first derivative of  $f(x) = \frac{2(3-x-x^2)}{(x-2)^3}$ , relative to  $x$  is given by  $f'(x) = \frac{2(x+7)(x-1)}{(x-2)^4}$

Further, obtain that, the second derivative of  $f(x)$ , relative to  $x$  as,

$$f''(x) = \frac{4(x+3)}{(x-2)^4} - \frac{4}{(x-2)} f'(x)$$

Sketch the graph of  $y = f(x)$ , indicating the stationary points - asymptotes and intercepts on  $ox$  and  $oy$  clearly.

Its is giver that,

$$f''(x) = \frac{-4(x^2 + 11x - 8)}{(x - 2)^5}$$

Determine the inflection points on  $y = f(x)$ . (assume that  $\sqrt{153} \approx 12.4$ )

- (b). A person of height  $h$  to his eye level is watching a picture, which is hanged from a vertical wall. He is at a certain distance from the wall. Height of the picture is  $3h$  and the lower horizontal edge of the picture is  $2h$  above the ground level.

Find the optimal distance to the observer from the wall so that the picture subtends the maximum angle on his eye in the vertical plane.

$$f(x) = \frac{2(3-x-x^2)}{(x-2)^3}$$

$$\frac{d[f(x)]}{dx} = \frac{(x-2)^3(-2-4x) - 2(3-x-x^2)3(x-2)^2}{(x-2)^6}$$

$$= \frac{-2x - 4x^2 + 4 + 8x - 18 + 6x + 6x^2}{(x-2)^4}$$

$$= \frac{2x^2 + 12x - 14}{(x-2)^4}$$

$$f'(x) = \frac{2(x+7)(x-1)}{(x-2)^4} //$$

Again differentiate with relative to  $x$

$$\frac{d[f'(x)]}{dx} = \frac{(x-2)^4(4x+12) - (2x^2+12x-14)4(x-2)^3}{(x-2)^8}$$

PAPERMASTER.LK



$$= \frac{(x-2)^4 \cdot 4(x+3)}{(x-2)^8} - \frac{4}{(x-2)} \cdot \frac{2(x^2+6x-7)}{(x-2)^4} \quad \text{--- (5)}$$

$$= \frac{4(x+3)}{(x-2)^4} - \frac{4}{(x-2)} f'(x) //$$

For the stationary points on  $y = f(x)$ ,  $f'(x) = 0$  --- (5)

$$\frac{2(x+7)(x-1)}{(x-2)^4} = 0 \Rightarrow x = -7, x = 1 \quad \text{--- (5)}$$

Also when the denominator of  $f'(x)$ , is equal to zero  $\Rightarrow x = 2$

- Now by constructing a table by considering above three x values.

	$x < -7$	$-7 < x < 1$	$1 < x < 2$	$2 < x$
$[f'(x)] \text{ sign}$	(+)	(-)	(+)	(+)
	(5)	(5)		
	$y = \frac{26}{243}$	$y = -2$	$y \rightarrow \infty$	

- For the point at which the curve of  $y = f(x)$  intersects y-axis (intercept on y-axis)

When  $x = 0$ ,  $f(0) = -\frac{3}{4} \Rightarrow (0, -\frac{3}{4})$  --- (5)

- For the intercepts on x-axis, when  $y = 0$

$$0 = \frac{2(3-x-x^2)}{(x-2)^3} \Rightarrow x^2 + x - 3 = 0$$

$$\therefore x = \frac{-1 \pm \sqrt{13}}{2} \quad \text{--- (5)}$$

$$x_1 = \frac{-1 - \sqrt{13}}{2}, (\approx -2.2) \Rightarrow (-2.2, 0)$$

$$x_2 = \frac{-1 + \sqrt{13}}{2}, (\approx 1.2) \Rightarrow (1.2, 0)$$

PAPERMASTER.LK

• As,  $y = \frac{-2x^2 - 2x + 6}{(x - 2)^3}$

$$y = \frac{-2x^2 - 2x + 6}{x^3 - 6x^2 + 12x - 8}$$

$$= \frac{\left(\frac{-2}{x} - \frac{2}{x^2} + \frac{6}{x^3}\right)}{\left(1 - \frac{6}{x} + \frac{12}{x^2} - \frac{8}{x^3}\right)}$$

When  $x \rightarrow \pm\infty$   
 $y = \frac{0 - 0 + 0}{1 - 0 + 0 - 0} \Rightarrow$

When  $x \rightarrow \pm\infty$   
 $y \rightarrow 0$   
 (Horizontal asymptote)

5

• When  $x = 2$   $y \rightarrow \infty$

$\therefore x = 2$  is a vertical asymptote

5

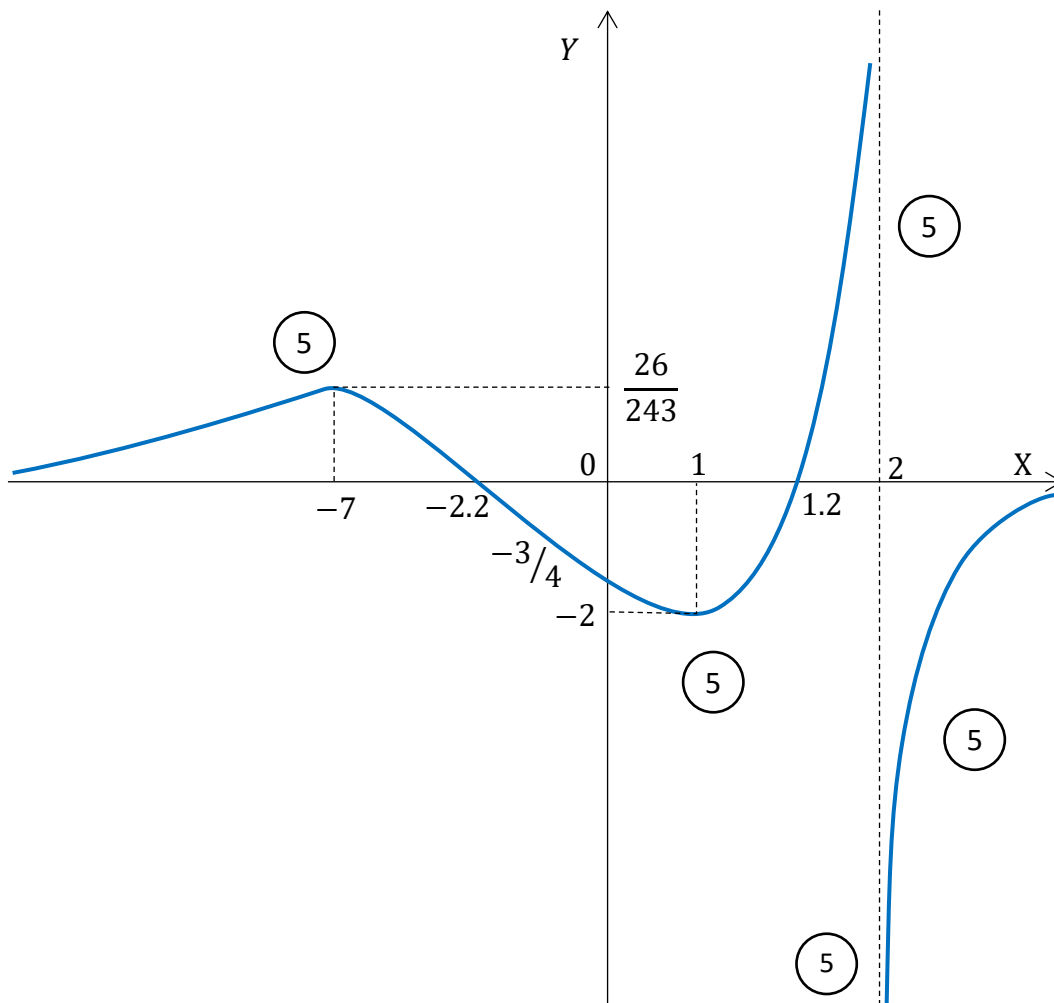

PAPERMASTER.LK



To determine the inflection points on  $y = f(x)$ , (if any)

$$f''(x) = 0 \Leftrightarrow \frac{-4(x^2 + 11x - 8)}{(x - 2)^5} = 0$$

$$\Leftrightarrow x = \frac{-11 \pm \sqrt{153}}{2}$$

$$= \frac{-11 \pm 12.4}{2} \Leftrightarrow \begin{matrix} \oplus, x_1 = 0.7 \\ \ominus, x_2 = -11.7 \end{matrix}$$

	$-\infty < x < -11.7$	$-11.7 < x < 0.7$	$0.7 < x < 2$
$[f''(x)]$ sign	$\oplus$	$\ominus$	$\oplus$
		(5)	(5)

$\therefore$  At  $x = -11.7$  sign of  $f''(x)$  changes from  $\oplus$  to  $\ominus$

At  $x = 0.7$  sign of  $f''(x)$  changes from  $\ominus$  to  $\oplus$

$\therefore x = -11.7$  and  $x = 0.7$  are the  $x$  values relevant to the inflection points on  $y = f(x)$

(5)

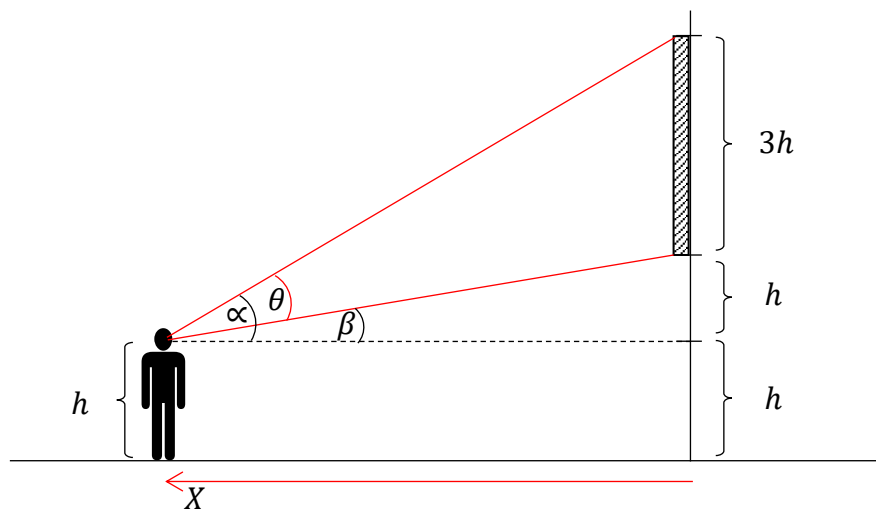

$$\theta = \alpha - \beta$$

$$\tan \theta = \tan(\alpha - \beta)$$

$$= \frac{\tan \alpha - \tan \beta}{1 + \tan \alpha \cdot \tan \beta}$$

(5)

PAPERMASTER.LK

$$= \frac{\left(\frac{4h}{x} - \frac{h}{x}\right)}{1 + \left(\frac{4h}{x}\right)\left(\frac{h}{x}\right)}$$

$$= \frac{3hx}{x^2 + 4h^2}$$

$$\Rightarrow \theta = \tan^{-1} \left( \frac{3hx}{x^2 + 4h^2} \right) \text{ ————— } \textcircled{5}$$

$$\therefore \frac{d\theta}{dx} = \frac{1}{\left(1 + \frac{9h^2 x^2}{(x^2 + 4h^2)^2}\right)} \left[ \frac{(x^2 + 4h^2) 3h - 3hx(2x)}{(x^2 + 4h^2)^2} \right] \text{ ————— } \textcircled{5}$$

$$= \frac{1}{(x^2 + 4h^2)^2 + 9h^2 x^2} [3h(x^2 + 4h^2 - 2x^2)]$$

$$= \frac{3h(4h^2 - x^2)}{(x^2 + 4h^2)^2 + 9h^2 x^2}$$

For min or max of  $\theta$  } —————  $\textcircled{5}$   
 When  $\frac{d\theta}{dx} = 0$

$$\Rightarrow \frac{3h(4h^2 - x^2)}{(x^2 + 4h^2)^2 + 9h^2 x^2} = 0 \text{ ————— } \textcircled{5}$$

$$\Rightarrow 4h^2 - x^2 = 0$$

$$\Rightarrow x^2 = 4h^2$$

$$\Rightarrow x = \pm 2h \text{ ————— } \textcircled{5}$$

But  $x > 0$

$$\therefore x \neq -2h$$

$$\therefore x = 2h \text{ ————— } \textcircled{5}$$

Now

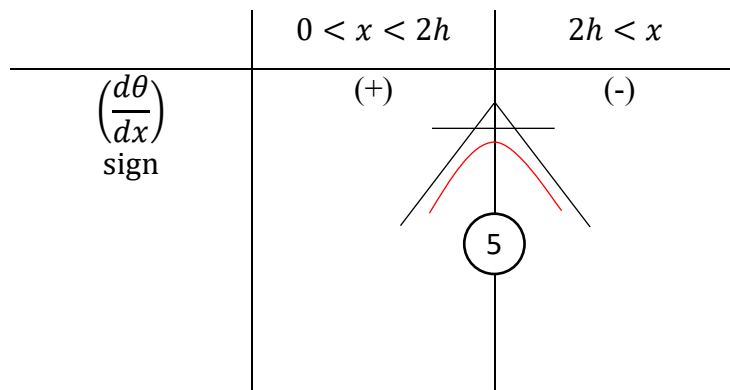

∴ When  $x = 2h$ ,  $\theta$  has a maximum

∴ To make the angle - which is subtended on his eye by the picture - a maximum, he has to observe the picture at a horizontal distance  $2h$  from the wall. ————— (5)

15. (a) By using the substitution  $x^3 = 2 \tan^2 \theta$  (for  $x > 0$ ) find  $\int \sqrt{x(2+x^3)} dx$

(b). Prove that  $\int_0^a f(x) dx = \int_0^a f(a-x) dx$

By using above result and by considering the integration  $\int_0^{\pi/2} \frac{\sin^2 \theta}{\cos^3 2\theta} d\theta$  (deduce that)

$$\int_0^{\pi/2} \sec^3 2\theta = 0$$

(c). Evaluate the integration  $\int_0^{\pi} \frac{e^{2x} \cos x - e^x \cos x}{1 - e^x} dx$

(a). When  $x^3 = 2 \tan^2 \theta$

$$3x^2 dx = 4 \tan \theta \sec^2 \theta d\theta \quad \text{—————} \textcircled{5}$$

$$I_0 = \int \sqrt{x(2+x^3)} dx$$

$$= \int x^{1/2} \sqrt{2+x^3} dx$$

$$= \int \frac{x^2 \sqrt{2+x^3}}{x^{3/2}} dx \quad \text{—————} \textcircled{5}$$

$$= \int \frac{\sqrt{(2+2 \tan^2 \theta)}}{\sqrt{2} \tan \theta} \frac{4}{3} \tan \theta \sec^2 \theta d\theta \quad \text{—————} \textcircled{5}$$

$$= \int \frac{\sqrt{2} \sqrt{(1+\tan^2 \theta)}}{\sqrt{2}} \frac{4}{3} \sec^2 \theta d\theta$$

$$= \frac{4}{3} \int \sec^3 \theta d\theta \quad \text{—————} \textcircled{5}$$

Let  $I = \int \sec^3 \theta d\theta$

$$I = \int \sec \theta \cdot \sec^2 \theta d\theta$$

$$= \int \sec \theta \cdot \frac{d}{d\theta} (\tan \theta) d\theta \quad \text{—————} \textcircled{5}$$

$$= \sec \theta \cdot \tan \theta - \int \tan \theta \cdot \frac{d}{d\theta} (\sec \theta) d\theta \quad \text{—————} \textcircled{5}$$

$$= \sec \theta \cdot \tan \theta - \int \tan \theta \cdot \sec \theta \tan \theta d\theta \quad \text{—————} \textcircled{5}$$

PAPERMASTER.LK



$$= \sec \theta \cdot \tan \theta - \int \sec \theta (\sec^2 \theta - 1) d\theta \quad \text{————— (5)}$$

$$= \sec \theta \cdot \tan \theta - \int \frac{\sec^3 \theta d\theta}{1} + \int \sec \theta d\theta \quad \text{————— (5)}$$

$$\therefore 2I = \sec \theta \cdot \tan \theta + \int \frac{\sec \theta (\sec \theta + \tan \theta)}{(\sec \theta + \tan \theta)} d\theta$$

$$= \sec \theta \cdot \tan \theta + \ln |\sec \theta + \tan \theta| \quad \text{————— (5)}$$

$$I_o = \frac{4}{3} I$$

$$= \frac{4}{3} \cdot \frac{1}{2} [\sec \theta \tan \theta + \ln |\sec \theta + \tan \theta|] \quad \text{————— (5)}$$

$$= \frac{2}{3} \sec \theta \tan \theta + \frac{2}{3} \ln |\sec \theta + \tan \theta| + c \quad // \quad \text{————— (5)}$$

(b). Let  $I = \int_0^a f(x) dx$

By substituting  $x = a - X$  ————— (5)

$$dx = -dX \quad \text{————— (5)}$$

Limits (when  $x = 0$ ) and (when  $x = a$ )  
 $X = a$  and  $X = 0$  ————— (5)

$$\therefore I = \int_a^0 f(a - X)(-) dX = - \int_a^0 f(a - X) dX \quad \text{————— (5)}$$

$$= \int_0^a f(a - X) dX$$

(5)

Now by considering  $X \rightarrow x$  (A definite integral is independent of the variable)

$$I = \int_0^a f(a - x) dx$$

$$\therefore \int_0^a f(x) dx = \int_0^a f(a - x) dx \quad \text{Now by applying this result for}$$

$$\int_0^{\pi/2} \frac{\sin^2 \theta}{\cos^3 2\theta} d\theta$$

————— (5)

————— (5)

$$\int_0^{\pi/2} \frac{\sin^2 \theta}{\cos^3 2\theta} d\theta = \int_0^{\pi/2} \frac{\sin^2(\pi/2 - \theta)}{\cos^3(\pi - 2\theta)} d\theta = \int_0^{\pi/2} \frac{\cos^2 \theta}{-\cos^3 2\theta} d\theta$$

PAPERMASTER.LK



$$\therefore \int_0^{\pi/2} \frac{\sin^2 \theta}{\cos^3 2\theta} d\theta + \int_0^{\pi/2} \frac{\cos^2 \theta}{\cos^3 2\theta} d\theta = 0 \Rightarrow \int_0^{\pi/2} \left( \frac{\sin^2 \theta + \cos^2 \theta}{\cos^3 2\theta} \right) d\theta = 0 \quad \text{--- (5)}$$

$$\Rightarrow \int_0^{\pi/2} \sec^3 2\theta d\theta = 0 \quad //$$

(C). Let  $I_c = \int_0^\pi \frac{e^{2x} \cos x - e^x \cos x}{1 - e^x} dx$

$$\therefore I_c = \int_0^\pi \frac{e^x \cdot e^x \cos x - e^x \cos x}{-(e^x - 1)} dx \quad \text{--- (5)}$$

$$= \int_0^\pi \frac{-e^x \cos x (e^x - 1)}{(e^x - 1)} dx = \int_0^\pi -e^x \cos x dx \quad \text{--- (5)}$$

$$= \int_\pi^0 e^x \cos x dx \quad \text{--- (5)}$$

$$= \int_\pi^0 \cos x \cdot \frac{d(e^x)}{dx} dx \quad \text{(By applying - Integration by parts) --- (5)}$$

$$= [e^x \cos x]_\pi^0 - \int_\pi^0 e^x \cdot \frac{d(\cos x)}{dx} dx \quad \text{--- (5)}$$

$$= [e^0 \cdot \cos 0 - e^\pi \cdot \cos \pi] + \int_\pi^0 e^x \cdot \sin x dx \quad \text{--- (5)}$$

$$= [1 + e^\pi] + \int_\pi^0 \sin x \cdot \frac{d(e^x)}{dx} dx \quad \text{(Again by Integration by parts)}$$

$$= [1 + e^\pi] + [\sin x \cdot e^x]_\pi^0 - \int_\pi^0 e^x \cdot \frac{d(\sin x)}{dx} dx \quad \text{--- (5)}$$

$$= [1 + e^\pi] + [\sin 0 \cdot e^0 - \sin \pi \cdot e^\pi] - \int_\pi^0 e^x \cos x dx \quad \text{--- (5)}$$

$$I_c = [1 + e^\pi] - I_c \quad \text{--- (5)}$$

$$\therefore 2I_c = [1 + e^\pi]$$

$$I_c = \frac{1}{2}[1 + e^\pi] \quad //$$

16. Find the co-ordinates of the intersection point  $P$  of the straight lines,

$$l_1 \equiv y = mx \text{ and } l_2 \equiv 2mx - 3y + 1 = 0 \text{ where } m > 0.$$

This point  $P$  is at a distance of  $\sqrt{2m}$  from the origin  $O$ . Show that  $m = 1$

Find the equation of the straight line  $l_3 = 0$  which is passing through above intersection point  $P$  and which makes an intercept of 2 units on the positive direction of  $x$ -axis.

When  $A$  is the point of intersection of  $l_2 = 0$  and  $y$ -axis, and  $B$  is the point of intersection of  $l_3 = 0$  and  $x$ -axis, find the equation of the circle  $S_1 = 0$  which is passing through the points  $O, A$  &  $B$ .

Further, find the equation of the circle  $S_2 = 0$  whose centre is  $P$  and radius  $PA$ .

Are  $S_1 = 0$  &  $S_2 = 0$  orthogonal. Justify your answer.

Find the equation of the circle whose centre is  $P$  and which is orthogonal to  $S_1 = 0$ .

By solving  $l_1 \equiv y = mx$  and  $l_2 \equiv 2mx - 3y + 1 = 0$

$$2mx - 3(mx) + 1 = 0$$

$$\therefore x = 1/m \Rightarrow y = m \left(\frac{1}{m}\right) = 1$$

$$\therefore p \equiv (1/m, 1) \quad // \quad \text{—————} \textcircled{5} \textcircled{5}$$

As the distance from  $O \equiv (0,0)$  to  $P$  is  $\sqrt{2m}$

$$\sqrt{\left(\frac{1}{m} - 0\right)^2 + (1 - 0)^2} = \sqrt{2m} \quad \text{—————} \textcircled{5}$$

$$\frac{1}{m^2} + 1 = 2m$$

$$1 + m^2 = 2m^3$$

$$2m^3 - m^2 - 1 = 0$$

$$(m - 1)(2m^2 + m + 1) = 0 \quad \text{—————} \textcircled{5}$$

$$\Delta m < 0 \Rightarrow \text{no real solutions for } m \quad \text{—————} \textcircled{5}$$

$$\therefore m = 1 \quad // \quad \text{—————} \textcircled{5} \text{ PAPERMASTER.LK}$$



\*  $l_1 \equiv mx - y = 0$  and  $l_2 \equiv 2mx - 3y + 1 = 0$

When  $m = 1 \rightarrow l_1 \equiv x - y = 0$  and

$$l_2 \equiv 2x - 3y + 1 = 0$$

Any straight line which passes through the intersection point of  $l_1 = 0$  and  $l_2 = 0$  can be expressed as  $l_1 + \lambda l_2 = 0$ ,  $\lambda \in \mathbb{R}$

$$\therefore x - y + \lambda(2x - 3y + 1) = 0 \quad \text{—————} \textcircled{10}$$

Required line makes an intercept of 2 units on x-axis, it passes through (2,0) ————  $\textcircled{5}$

$$\therefore \text{By substituting } (2,0) \rightarrow 2 - 0 + \lambda(2 \cdot 2 - 3 \cdot 0 + 1) = 0, \lambda = -2/5 \quad \text{—————} \textcircled{5}$$

$\therefore$  The required line

$$l_3 \equiv x - y - \frac{2}{5}(2x - 3y + 1) = 0$$

$$l_3 \equiv x + y - 2 = 0 \quad // \quad \text{—————} \textcircled{5}$$

The point at which, the line  $l_2 = 0$  cuts the y-axis,  $A \equiv (0, 1/3)$  ————  $\textcircled{5}$

The point at which, the line  $l_3 = 0$  cuts the x-axis,  $B \equiv (2, 0)$  ————  $\textcircled{5}$

Also  $O \equiv (0,0)$

Let, the circle passing through  $O, A$  &  $B$

$$S_1 \equiv x^2 + y^2 + 2g_1x + 2f_1y + c_1 = 0$$

$$O(0,0) \rightarrow 0 + 0 + 0 + 0 + c_1 = 0$$

$$c_1 = 0 \quad // \quad \text{—————} \textcircled{5}$$

$$A(0, 1/3) \rightarrow 0 + \left(\frac{1}{3}\right)^2 + 2g_1(0) + 2f_1\left(\frac{1}{3}\right) + 0 = 0$$

$$f_1 = \frac{-1}{6} \quad // \quad \text{—————} \textcircled{5}$$

$$B(2,0) \rightarrow 2^2 + 0^2 + 2g_1(2) + 2f_1(0) + 0 = 0$$

$$g_1 = -1 \quad // \quad \text{—————} \textcircled{5}$$

$\therefore$  The required circle

$$S_1 \equiv x^2 + y^2 + 2(-1)x + 2\left(\frac{-1}{6}\right)y + (0) = 0 \quad \text{—————} \textcircled{5}$$

$$3x^2 + 3y^2 - 6x - y = 0 \quad //$$



$$* P \equiv (1/m, 1) \xrightarrow{m=1} P \equiv (1,1) \text{ and } A \equiv (0, 1/3)$$

$$\begin{aligned} \therefore PA &\equiv \sqrt{(1-0)^2 + (1-1/3)^2} \\ &\equiv \sqrt{1 + 4/9} \\ &\equiv \frac{\sqrt{13}}{3} \text{ Units} \quad \text{-----} \textcircled{5} \end{aligned}$$

Let the circle  $S_2 = 0$  whose centre is at P and the radius PA

$$S_2 \equiv x^2 + y^2 + 2g_2x + 2f_2y + c_2 = 0$$

$$\text{Centre } (-g_2, -f_2) \equiv P \equiv (1,1)$$

$$\Rightarrow -g_2 = 1 \quad \text{and} \quad -f_2 = 1$$

$$g_2 = -1 // \quad \textcircled{5} \quad f_2 = -1 // \quad \textcircled{5}$$

Also, the radius = PA

$$\begin{aligned} r &= \sqrt{g_2^2 + f_2^2 - c_2} \\ \Rightarrow \sqrt{(-1)^2 + (-1)^2 - c_2} &= \frac{\sqrt{13}}{3} \quad \text{-----} \textcircled{5} \end{aligned}$$

$$2 - c_2 = \frac{13}{9} \Rightarrow c_2 = \frac{5}{9} // \quad \text{-----} \textcircled{5}$$

$$\therefore S_2 \equiv x^2 + y^2 + 2(-1)x + 2(-1)y + \left(\frac{5}{9}\right) = 0$$

$$x^2 + y^2 - 2x - 2y + \left(\frac{5}{9}\right) = 0 // \quad \text{-----} \textcircled{5}$$

Constants of the circle  $S_1 = 0$  and  $S_2 = 0$  are ,

$$g_1 = -1 \quad g_2 = -1$$

$$f_1 = -1/6 \quad f_2 = -1$$

$$c_1 = 0 \quad c_2 = 5/9$$

PAPERMASTER.LK





17. (a). State the "Cosine rule" for a triangle  $ABC$  in usual notation.

i. Lengths of the sides  $BC, CA$  and  $AB$  of a triangle  $ABC$  are  $(x + y), x$  and  $(x - y)$  respectively.

Show that,

$$\cos A = \frac{x - 4y}{2(x - y)}$$

ii. If  $y = x/7$  obtain  $\hat{A} = \cos^{-1}(1/4)$

iii. Lengths of three sides of a triangle are in the ratio 6:7:8.

Deduce that the largest angle of the triangle is,  $\cos^{-1}(1/4)$

(b). Prove that,  $(\cos \alpha + \cos \beta)^2 + (\sin \alpha + \sin \beta)^2 = 4 \cos^2 \left( \frac{\alpha - \beta}{2} \right)$  and

find the general solutions of the equation,

$$(\cos x + \cos 3x)^2 + (\sin x + \sin 3x)^2 = 1$$

(c). Solve the equation,  $2 \tan^{-1}(\sin x) - \tan^{-1}(2 \sec x) = 0$

(a.) For any acute angled, right angled or obtuse angled triangle in usual notation

$$\left. \begin{aligned} \cos A &= \frac{b^2 + c^2 - a^2}{2bc} \\ \cos B &= \frac{a^2 + c^2 - b^2}{2ac} \\ \cos C &= \frac{a^2 + b^2 - c^2}{2ab} \end{aligned} \right\} \text{--- (10)}$$

(i)

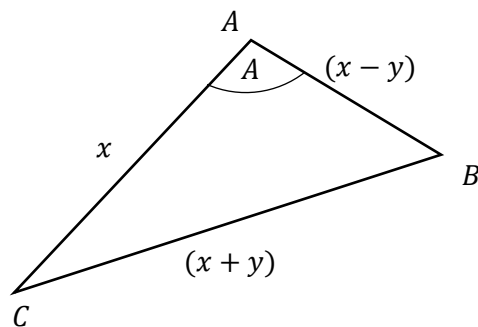

$$\cos A = \frac{x^2 + (x - y)^2 - (x + y)^2}{2x(x - y)} \text{--- (5)}$$

$$= \frac{x^2 - 4xy}{2x(x - y)} \text{--- (5)}$$

$$\therefore \cos A = \frac{x - 4y}{2(x - y)} //$$

When  $y = x/7$

$$\cos A = \frac{x - 4\frac{x}{7}}{2(x - \frac{x}{7})} \text{ ————— } \textcircled{5}$$

$$= \frac{3x/7}{12x/7} \text{ ————— } \textcircled{5}$$

$$\therefore \cos A = 1/4 \Rightarrow A = \cos^{-1}(1/4) \quad //$$

(ii) If the lengths sides of a triangle are in the ratio 6:7:8, then by considering in ascending order, the lengths can be expressed as,

$$\frac{6x}{7}, \frac{7x}{7} \text{ and } \frac{8x}{7} \text{ ————— } \textcircled{5}$$

By taking those lengths as  $(x - \frac{x}{7}), x$  and  $(x + \frac{x}{7})$  and by taking  $x/7 = y$  ————  $\textcircled{5}$

$\Rightarrow (x - y), x$  and  $(x + y)$ . Then the longest side is  $(x + y)$  and the largest angle is the angle opposite to longest side, ————  $\textcircled{5}$

$$\therefore \text{Largest angle} = \cos^{-1}(1/4) \text{ ————— } \textcircled{5}$$

(b).  $(\cos \alpha + \cos \beta)^2 + (\sin \alpha + \sin \beta)^2$

$$= \cos^2 \alpha + \sin^2 \alpha + \cos^2 \beta + \sin^2 \beta + 2(\cos \alpha \cos \beta + \sin \alpha \sin \beta) \text{ ————— } \textcircled{5}$$

$$= 2 + 2 \cos(\alpha - \beta)$$

$$= 2 + 2 \cos 2 \left( \frac{\alpha - \beta}{2} \right) \text{ ————— } \textcircled{5}$$

$$= 2 + 2 \left[ 2 \cos^2 \left( \frac{\alpha - \beta}{2} \right) - 1 \right] \text{ ————— } \textcircled{5}$$

$$= 2 + 4 \cos^2 \left( \frac{\alpha - \beta}{2} \right) - 2 \text{ ————— } \textcircled{5}$$

$$= 4 \cos^2 \left( \frac{\alpha - \beta}{2} \right) //$$

By substituting  $\alpha = x$  and  $\beta = 3x$  in above result,

$$(\cos \alpha + \cos \beta)^2 + (\sin \alpha + \sin \beta)^2 = 4 \cos^2 \left( \frac{\alpha - \beta}{2} \right)$$

$$(\cos x + \cos 3x)^2 + (\sin x + \sin 3x)^2 = 4 \cos^2 \left( \frac{x - 3x}{2} \right) \quad \text{————— (10)}$$

Now, it is given that

$$(\cos x + \cos 3x)^2 + (\sin x + \sin 3x)^2 = 1$$

$$1 = 4 \cos^2 \left( \frac{-2x}{2} \right) \quad \text{————— (5)}$$

$$\cos^2 x = \frac{1}{4}, \quad (\because \cos(-\theta) = \cos \theta)$$

$$\cos x = \pm \frac{1}{2} \quad \text{————— (5)}$$

⊕ by considering

$$\begin{aligned} \cos x &= \frac{1}{2} \\ \cos x &= \cos\left(\frac{\pi}{3}\right) \\ x &= 2n\pi \pm \frac{\pi}{3} \quad // \\ &\quad \text{(5)} \quad n \in \mathbb{Z} \end{aligned}$$

⊖ by considering

$$\begin{aligned} \cos x &= -\frac{1}{2} \\ \cos x &= -\cos\left(\frac{\pi}{3}\right) \\ \cos x &= \cos\left(\pi - \frac{\pi}{3}\right) \\ \cos x &= \cos\left(2\frac{\pi}{3}\right) \quad \text{————— (5)} \\ x &= 2n\pi \pm 2\frac{\pi}{3} \quad // \\ &\quad n \in \mathbb{Z} \quad \text{————— (5)} \end{aligned}$$

(c).  $2 \tan^{-1}(\sin x) - \tan^{-1}(2 \sec x) = 0$

When  $\tan^{-1}(\sin x) = \alpha$  and  $\tan^{-1}(2 \sec x) = \beta$

$\tan \alpha = \sin x$  and  $\tan \beta = 2 \sec x$

Then

$$2 \alpha - \beta = 0 \quad \text{————— (5)}$$

$$2 \alpha = \beta$$

$$\tan 2 \alpha = \tan \beta \quad \text{————— (5)}$$

$$\frac{2 \tan \alpha}{1 - \tan^2 \alpha} = \tan \beta \quad \text{————— (5)}$$

PAPERMASTER.LK



$$2 \sin x = 2 \sec x (1 - \sin^2 x)$$

$$\sin x = \sec x (\cos^2 x) \quad \text{—————} \textcircled{5}$$

$$\sin x = \cos x$$

$$\cos\left(\frac{\pi}{2} - x\right) = \cos x \quad \text{—————} \textcircled{5}$$

$$\therefore \frac{\pi}{2} - x = 2n\pi \pm x \quad \text{—————} \textcircled{5}$$

$$\oplus \Rightarrow \frac{\pi}{2} - x = 2n\pi + x$$

$$2x = \frac{\pi}{2} - 2n\pi$$

$$x = \frac{\pi}{2} \left( \frac{1}{2} - 2n \right) \quad // \quad n \in \mathbb{Z} \quad \text{—————} \textcircled{5}$$

$$\ominus \Rightarrow \frac{\pi}{2} - x = 2n\pi - x$$

$$\text{(solution of } x \text{ are undetermined)} \quad \text{—————} \textcircled{5}$$



G.C.E. Advanced Level  
Grade 13  
**Combined Mathematics II**  
Three hours



**Part A**  
**Answers**

(01) Two particles of masses  $3m$  and  $\lambda m$  are moving in the same straight line on a smooth horizontal table in opposite directions with velocities  $\lambda u$  and  $u$  respectively and collide directly. After the collision the particle of mass  $3m$  comes to rest. Find the velocity of the other particle and also find the coefficient of restitution between the two particles.

Further, show that  $\lambda = 1$  if there is no loss of kinetic energy in the system due to the collision. What is the impulse of the collision.

Solution -

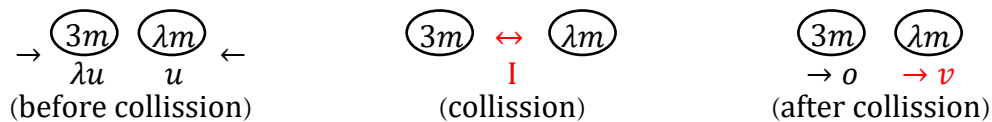

→ Newtons law of restitution

$$v - 0 = -e(-u - \lambda u)$$

$$v = (\lambda + 1)eu \quad \text{--- (1) --- (5)}$$

→ Principle of conservation of linear momentum

$$\lambda m \cdot v + 0 = -\lambda m u + 3m \cdot \lambda u$$

$$v = 2u \quad // \quad \text{--- (5)}$$

$$\therefore \text{(1)} \Rightarrow 2u = (\lambda + 1)eu$$

$$e = \left(\frac{2}{\lambda + 1}\right) \quad // \quad \text{--- (5)}$$

If there is no loss of energy, the collision is perfect elastic.

$$\therefore e = 1$$

$$\text{then } 1 = \frac{2}{\lambda + 1} \quad \text{--- (5)}$$

$$\Rightarrow \lambda = 1 //$$

$$\text{Now } (3m) \leftarrow I = \Delta(mv)$$

$$I = 0 - (3m)(-\lambda u)$$

$$= 3mu // \quad \text{--- (5)}$$

(02). An aircraft which is moving with velocity  $360 \text{ Km h}^{-1}$  on a straight level track takes off from the point O at an inclination  $\pi/6$  to the horizontal. After flying one minute with the same uniform velocity it releases a bomb at rest.

Find the distance from O, to the point at which the bomb hits on the ground.

Solution -

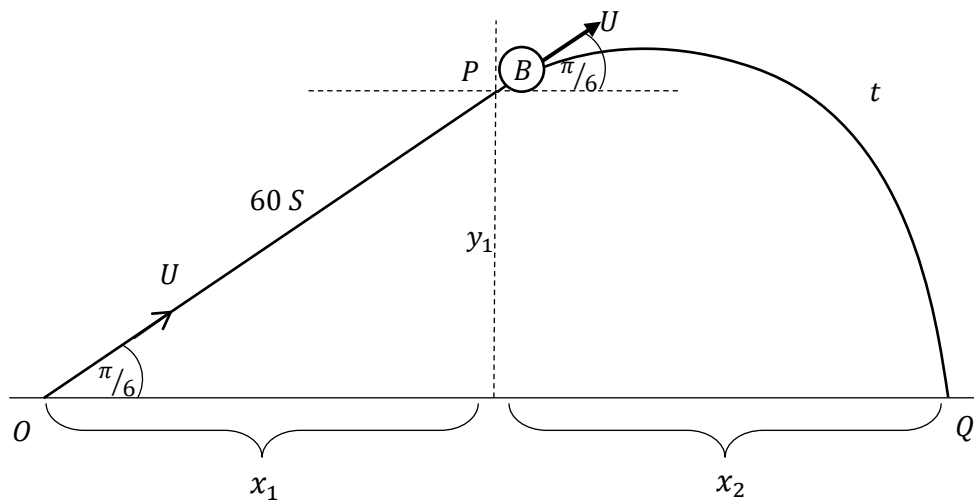

$$u = 360 \times \frac{5}{18} \text{ m s}^{-1}$$

$$= 100 \text{ m s}^{-1}$$

(o → p) motion

$$\nearrow s = ut$$

$$OP = (100)(60)$$

$$= 6000 \text{ m} \quad \text{--- (5)}$$

$$\therefore x_1 = 6000 \cos(\pi/6)$$

$$= 3000\sqrt{3} \text{ m} //$$

(P → Q) motion of bomb

$$\uparrow s = ut + \frac{1}{2}at^2$$

$$-3000 = u \cos(\pi/3) \cdot t - \frac{1}{2}(10)t^2 \quad \text{--- (5)}$$

$$-3000 = 50t - 5t^2$$

$$5t^2 - 50t - 3000 = 0$$

$$t^2 - 10t - 600 = 0$$

$$(t + 20)(t - 30) = 0 \quad \text{--- (5)}$$



$$y_1 = 6000 \cos(\pi/3)$$

$$= 3000 \text{ m} //$$

$$\therefore OQ \text{ distance} = x_1 + x_2$$

$$= 3000\sqrt{3} + 1500\sqrt{3}$$

$$= 4500\sqrt{3} \text{ m}$$

$$= 4.5\sqrt{3} \text{ km} //$$

5

$$t > 0 \Rightarrow t = 30 \text{ s} //$$

$$\therefore (P \rightarrow Q) \text{ bomb}$$

$$\rightarrow s = ut + \frac{1}{2}at^2$$

$$x_2 = u \cos(\pi/6) \cdot t + 0$$

$$= 100 \frac{\sqrt{3}}{2} 30$$

$$= 1500\sqrt{3} \text{ m}$$

5

(03). As shown in the figure, two smooth pulleys  $P$  and  $Q$  are fixed at the two ends of an inclined plane which is  $\theta$  to the horizontal. The smooth particle  $B$ , which is on the inclined plane is attached to the ends of two inextensible light strings. This strings pass over the pulleys  $P$  and  $Q$  and the particles  $A$  and  $B$  are attached to the other ends. Masses of  $A, B$ , and  $C$  are  $2m, 3m$  and  $3m$  respectively.

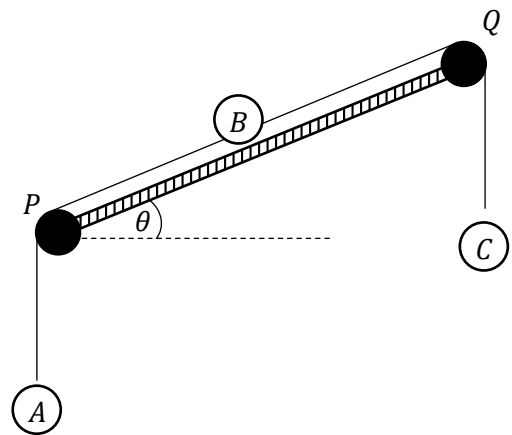

Find the acceleration where the system is released from rest.

If the particle  $A$  moves vertically upwards, then show that,  $\theta < \sin^{-1}(1/3)$

Solution -

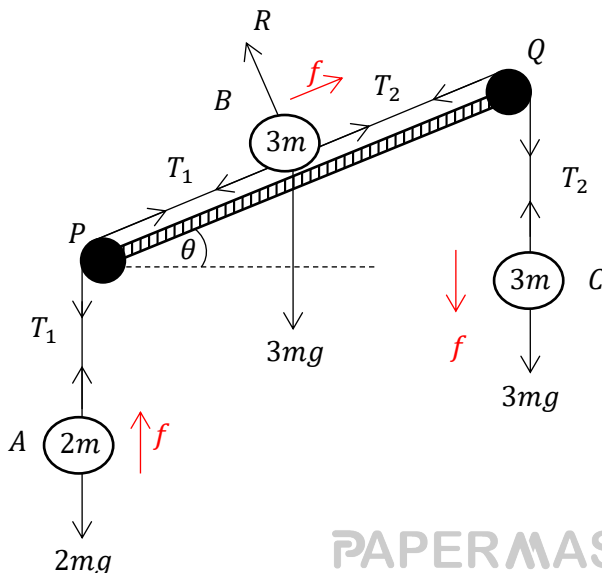

PAPERMASTER.LK



Applying  $F = ma$

$$\textcircled{A}, \uparrow \Rightarrow T_1 - 2mg = 2mf \quad \textcircled{1} \quad \text{—————} \quad \textcircled{5}$$

$$\textcircled{C}, \downarrow \Rightarrow 3mg - T_2 = 3mf \quad \textcircled{2} \quad \text{—————} \quad \textcircled{5}$$

$$\textcircled{B}, \nearrow \Rightarrow T_2 - T_1 - 3mg \sin \theta = 3mf \quad \textcircled{3} \quad \text{—————} \quad \textcircled{5}$$

$$\textcircled{1} + \textcircled{2} + \textcircled{3} \Rightarrow mg - 3mg \sin \theta = 8mf$$

$$f = \left( \frac{1 - 3 \sin \theta}{8} \right) g \quad // \quad \text{—————} \quad \textcircled{5}$$

If the particle  $\textcircled{A}$  moves vertically upwards  $f > 0$

$$\Rightarrow \left( \frac{1 - 3 \sin \theta}{8} \right) g > 0 \Rightarrow 1 - 3 \sin \theta > 0 \quad \text{—————} \quad \textcircled{5}$$

$$\Rightarrow \theta < \sin^{-1}(1/3) \quad //$$

(04). The power of the engine of a vehicle is  $10^3 HK$  W. The maximum velocity which it can maintain along a level track is  $90 \text{ km h}^{-1}$ . Find the total resistance to the motion of the vehicle.

Calculate the acceleration of the vehicle when it is moving up on an inclined straight road with the same resistance and power, if the inclination is  $\pi/6$  to the horizontal with speed  $54 \text{ km h}^{-1}$ .

Total mass of the vehicle is K metric tons.

Solution -

$$H = 10^3 HK$$

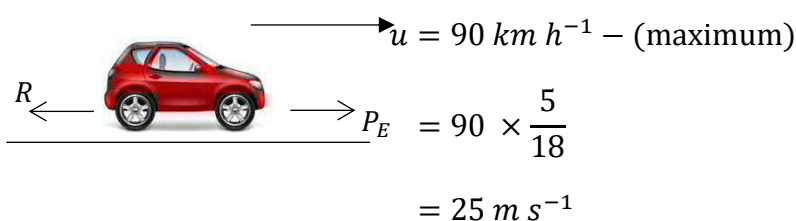

$$H = PV$$

$$10^3 HK = P_E \cdot 25 \quad \text{—————} \quad \textcircled{5}$$

$$P_E = 40HK \text{ N} \quad \text{PAPERMASTER.LK}$$

For vehicle  $\rightarrow \underline{F} = m\underline{a}$

$$P_E - R = m(0) \quad (\because \text{maximum velocity})$$

$$\text{Total resistance } R = P_E = 40HK \text{ N} \quad // \quad \text{—————} \quad \textcircled{5}$$

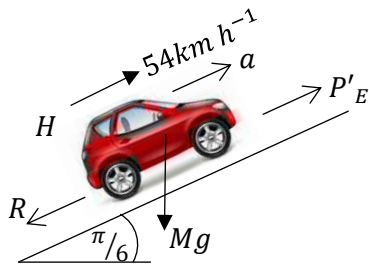

$$H = PV$$

$$10^3 HK = P'_E \left( 54 \times \frac{5}{18} \right) \quad \text{—————} \quad \textcircled{5}$$

$$\therefore P'_E = \frac{200}{3} HK \text{ N}$$

$$\nearrow F = ma$$

$$P'_E - R - mg \sin\left(\frac{\pi}{6}\right) = ma \quad \text{—————} \quad \textcircled{5}$$

$$\frac{200}{3} HK - 40HK - 10^3 K g \frac{1}{2} = 10^3 K \cdot a$$

$$\frac{80H}{3} - 500g = 10^3 a$$

$$\left(\frac{8H}{3} - 50g\right) \frac{1}{500} = a$$

$$a = \frac{1}{750} (4H - 75g) m s^{-2} \quad // \quad \text{—————} \quad \textcircled{5}$$

- (05). As show in the figure AB and BC are thin smooth wires which are circular arcs of equal radii and there centers are P and Q respectively. Both are of quadrant shaped arcs. At B a smooth bead of mass  $2m$  and at A another smooth bead of mass  $m$  are attached to the wire. Entire wire is in a verticle place. When the particle which is at A is released from rest it moves along wire AB and hits on the particle  $2m$  at B and combined. And then the combined prticle starts to move along wire BC. Show that the angle between QB verticle line and the radius through the combined particle  $\cos^{-1}\left(\frac{20}{27}\right)$  when the reaction between wire and combined particle is zero.

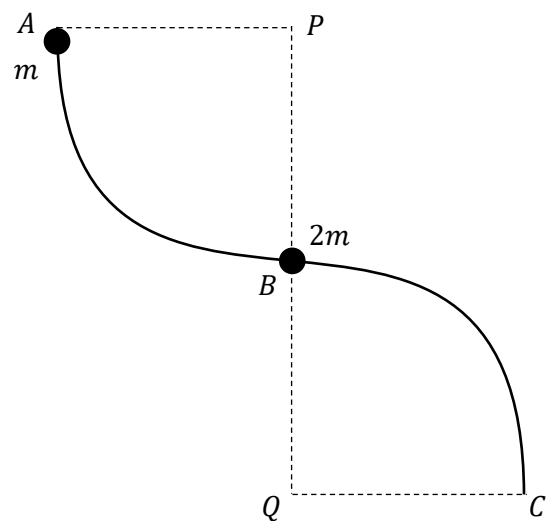

Answer -

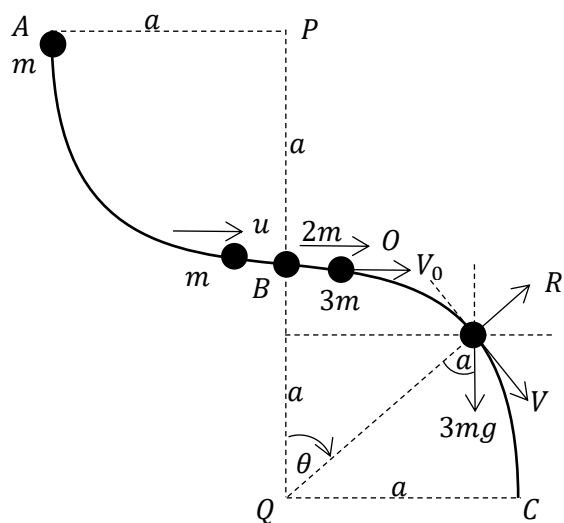

(A  $\rightarrow$  B) motion of mass  $m$   
 $A(\text{K.E.} + \text{P.E.}) = B(\text{K.E.} + \text{P.E.})$

$$0 + mga = \frac{1}{2}mu^2 + 0$$

$$u = \sqrt{2ga} \quad \text{--- (5)}$$

Collision of  $M$  &  $2m$  at B  
 P.C.L.M.

$$3mV_0 = mu + 2mO$$

$$V_0 = \frac{u}{3} = \frac{1}{3}\sqrt{2ga} \quad \text{--- (5)}$$

By considering the circular motion, of the combined particle.

$$\frac{1}{2}3mV_0^2 + 0 = \frac{1}{2}3m.V^2 - 3mg(a - a \cos \theta)$$

$$V_0^2 = V^2 - 2ga(1 - \cos \theta) \quad \text{--- (5)}$$

$$\frac{1}{9} \cdot 2ga = V^2 - 2ga + 2ga \cos \theta$$

$$V^2 = ga \left[ \frac{2}{9} + 2 - 2 \cos \theta \right]$$

$$= ga \left[ \frac{20}{9} - 2 \cos \theta \right]$$

Now  $\sum F = ma$

$$3mg \cos \theta - R = 3m \frac{V^2}{a} \quad \text{--- (5)}$$

When reaction on combined particle from wire  $R = 0$

$$g \cos \theta = \frac{V^2}{a}$$

$$ga \cos \theta = ga \left[ \frac{20}{9} - 2 \cos \theta \right] \quad \text{--- (5)}$$

$$3 \cos \theta = \frac{20}{9}$$

$$\cos \theta = \frac{20}{27}$$

$$\theta = \cos^{-1} \left( \frac{20}{27} \right) //$$

(06). Position vectors of the vertices of the rhombus, with relative to vector origin  $O$  are

$\vec{OP} = -3\vec{i} - 5\vec{j}$ ,  $\vec{OQ} = 3\vec{i} - 3\vec{j}$ ,  $\vec{OR} = \alpha\vec{i} + \beta\vec{j}$  and  $\vec{OS} = -\vec{i} + \vec{j}$ . Determine the values of  $\alpha$  &  $\beta$  and show that the diagonals  $PR$  &  $QS$  bisect each other perpendicularly

Answer -

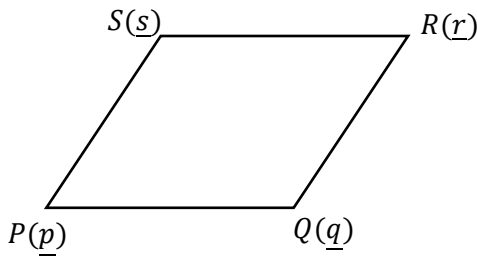

$$\vec{OP} = \underline{p} = -3\underline{i} - 5\underline{j}$$

$$\vec{OQ} = \underline{q} = 3\underline{i} - 3\underline{j}$$

$$\vec{OR} = \underline{r} = \alpha \underline{i} + \beta \underline{j}$$

$$\vec{OS} = \underline{s} = -\underline{i} + \underline{j}$$

❖ As PQRS is a rhombus

$$\left. \begin{array}{l} PQ = SR \\ PQ \parallel SR \end{array} \right\} \Rightarrow$$

$$\vec{PQ} = \vec{SR}$$

$$\underline{q} - \underline{p} = \underline{r} - \underline{s}$$

$$(P \rightarrow Q \text{ sence}) = (S \rightarrow R \text{ sence}) \quad 6\underline{i} + 2\underline{j} = (\alpha + 1)\underline{i} + (\beta - 1)\underline{j}$$

$$\Rightarrow \alpha + 1 = 6 \quad \beta - 1 = 2$$

5

$$\alpha = 5 \quad \beta = 3$$

5

∴ Position vector of R is

$$\vec{OR} = \underline{r} = 5\underline{i} + 3\underline{j}$$

Now

$$\vec{PR} = \underline{r} - \underline{p} = 8\underline{i} + 8\underline{j}$$

$$\vec{SQ} = \underline{q} - \underline{s} = 4\underline{i} - 4\underline{j}$$

$$\therefore \vec{PR} \cdot \vec{SQ} = (8\underline{i} + 8\underline{j}) \cdot (4\underline{i} - 4\underline{j})$$

$$= 32(\underline{i} \cdot \underline{i}) - 32(\underline{i} \cdot \underline{j}) + 32(\underline{j} \cdot \underline{i}) - 32(\underline{j} \cdot \underline{j})$$

$$= 32 - 32 = 0$$

5

∴ Diagonals PR & QS are perpendicular to each other. ⊥

<p>Futher</p> <p>Midpoint of PR <math>\equiv \left[ \left( \frac{5-3}{2} \right) : \left( \frac{3-5}{2} \right) \right]</math></p> <p><math>\equiv (1, -1)</math></p> <p>Midpoint of QS <math>\left[ \left( \frac{3-1}{2} \right) : \left( \frac{-3+1}{2} \right) \right]</math></p> <p><math>\equiv (1, -1)</math></p> <p>Midpoint of PR &amp; QS are coincident ∴ bisect each other.</p> <p>∴ The diagonals PR &amp; QS bisect each other perpendicularly //</p>	<p>Or another method</p> <p>Position vector of mid point of PR</p> $= \vec{OP} + \frac{1}{2}\vec{PR} = 3\underline{i} - 5\underline{j} + \frac{1}{2}(8\underline{i} + 8\underline{j})$ <p><math>= \underline{i} - \underline{j} \quad \text{--- (1)}</math></p> <p>Position vector of mid point of SQ</p> $= \vec{OS} + \frac{1}{2}\vec{SQ} = -\underline{i} + \underline{j} + \frac{1}{2}(4\underline{i} + 4\underline{j})$ <p><math>= \underline{i} - \underline{j} \quad \text{--- (2)}</math></p> <p><math>\text{(1)} = \text{(2)}</math></p> <p>∴ Mid point are coincident.</p>
--	--



- (08). A rough sphere of weight  $W$  and radius  $3r$  is kept in equilibrium on a rough inclined plane with inclination  $\pi/6$  to the horizontal by joining one end of a light inextensible string to a point on the sphere and the other end to a point  $P$  on the plane. Point  $P$  is above the point  $Q$  at which the sphere touches the plane. Distance  $PQ$  is  $4r$ . Mark the forces on the sphere and find the normal reaction on sphere.

Answer -

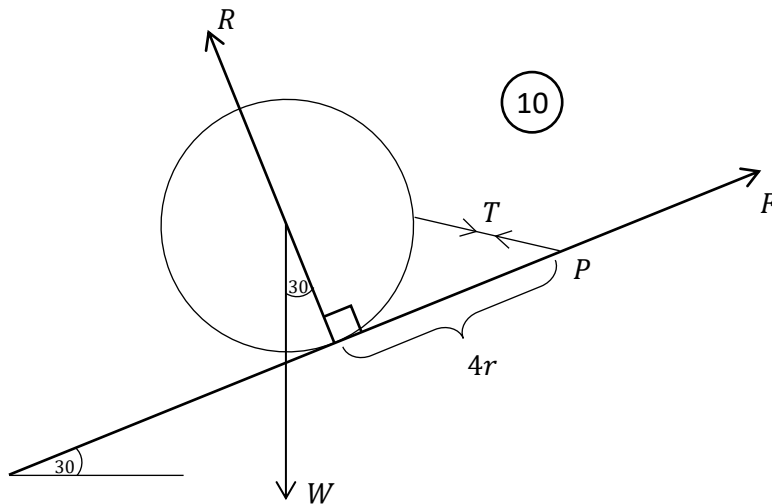

Taking moments about  $P$ , by considering the equilibrium of sphere.

$$\overset{\curvearrowright}{P} = \overset{\curvearrowleft}{P}$$

$$W \cos 30^\circ \cdot 4r + W \sin 30^\circ \cdot 3r = R \cdot 4r \quad \text{--- (10)}$$

$$W \cdot \frac{\sqrt{3}}{2} \cdot 4 + W \cdot \frac{1}{2} \cdot 3 = 4r$$

$$\therefore R = \frac{W}{8} (4\sqrt{3} + 3) \quad // \quad \text{--- (5)}$$

- (09). Following probabilities are given about the events  $A, B, C$  of which  $A$  &  $C$  are independent.

$$P(A) = \frac{1}{5}, \quad P(B) = \frac{1}{6}, \quad P(A \cap C) = \frac{1}{20} \quad \text{and} \quad P(B \cup C) = \frac{3}{8}$$

Find the probability of event  $C$  and show that the events  $B$  &  $C$  are independent.

Answer -

As the events A & C are independent,

$$P(A \cap C) = P(A) P(C)$$

$$\therefore \frac{1}{20} = \frac{1}{5} \cdot P(C)$$

$$\therefore P(C) = \frac{1}{4} \quad // \quad \text{—————} \textcircled{5}$$

$$P(B \cup C) = P(B) + P(C) - P(B \cap C) \quad \text{—————} \textcircled{5}$$

$$\frac{3}{4} = \frac{1}{6} + \frac{1}{4} - P(B \cap C)$$

$$\begin{aligned} \therefore P(B \cap C) &= \frac{1}{6} + \frac{1}{4} - \frac{3}{8} \\ &= \frac{4 + 6 - 9}{24} \end{aligned}$$

$$= \frac{1}{24} - \textcircled{1} \quad \text{—————} \textcircled{5}$$

$$P(B) P(C) = \frac{1}{6} \cdot \frac{1}{4} = \frac{1}{24} - \textcircled{2} \quad \text{—————} \textcircled{5}$$

$$\textcircled{1} = \textcircled{2}$$

$$\begin{aligned} \Rightarrow P(B \cap C) &= P(B) P(C) \\ \therefore \text{the events B \& C are also independent.} \end{aligned} \quad \left. \vphantom{\begin{aligned} \Rightarrow P(B \cap C) &= P(B) P(C) \\ \therefore \text{the events B \& C are also independent.} \end{aligned}} \right\} \textcircled{5}$$

(10). The mean of the set of numbers 1, 2, 8, 9 is increased by 1 when the positive number x is added to the set.

Determine the value of x and show that the increment in the standard deviation due to the addition of the positive number x to set, is  $\left(\frac{2\sqrt{7}-5}{\sqrt{2}}\right)$

Answer -

original set of numbers

$$\begin{aligned} \bar{x}_1 = \mu_1 &= \frac{1 + 2 + 8 + 9}{4} \\ &= 5 \end{aligned} \quad \text{--- (5)}$$

$$\begin{aligned} \sigma_1^2 &= \frac{\sum(x_i - \mu)^2}{n} \\ &= \frac{(5-1)^2 + (5-2)^2 + (5-8)^2 + (5-9)^2}{4} \\ &= \frac{16 + 9 + 9 + 16}{4} \end{aligned}$$

$$\sigma_1^2 = \frac{25}{4}$$

$$\therefore \sigma_1 = \frac{5}{\sqrt{2}} \quad \text{--- (5)}$$

New set of numbers

$$\bar{x}_2 = \mu_2 = \frac{1 + 2 + 8 + 9 + x}{5}$$

$$\mu_1 + 1 = \frac{20 + x}{5}$$

$$6 = \frac{20 + x}{5}$$

$$x = 10 \quad \text{--- (5)}$$

$$\sigma_2^2 = \frac{\sum(x_i - \mu)^2}{n}$$

$$= \frac{(6-1)^2 + (6-2)^2 + (6-8)^2 + (6-9)^2 + (6-10)^2}{5}$$

$$= \frac{25 + 16 + 4 + 9 + 16}{5}$$

$$\sigma_2^2 = 14$$

$$\sigma_2 = \sqrt{14} \quad \text{--- (5)}$$

Increments is standard deviation =  $\sigma_2 - \sigma_1$

$$= \sqrt{14} - \frac{5}{\sqrt{2}}$$

$$= \left( \frac{2\sqrt{7} - 5}{\sqrt{2}} \right) \quad \text{--- (5)}$$

### Part B

(11).(a). A particle A is projected vertically upwards under gravity with initial velocity  $\sqrt{10ga}$  from a point on the ground. When it is at height  $\frac{9a}{2}$  from the ground it separates to two parts P & Q of equal masses due to an internal explosion. Instantly the velocity of P comes to zero.

Show that the velocity of Q is double the velocity which was before the explosion.

Draw the velocity-time graphs of the motions of the particle A and the parts P & Q until P comes to the ground.

Hence find,

- (i) Height to the P from the ground when Q is at the highest point of its path.
- (ii) Time taken to P to comes to the ground from the instant  $t = 0$

Answer -

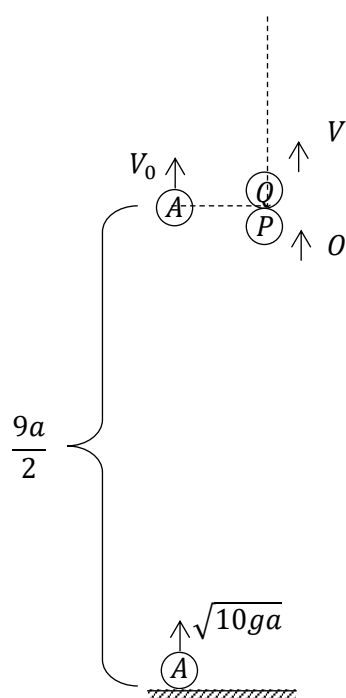

By considering the motion of A up to the point of explosion.

By applying  $\uparrow, V^2 = U^2 + 2as$

$$V_0^2 = 10ga - 2g \frac{9a}{2}$$

$$= ga$$

$$V_0 = \sqrt{ga} \quad \text{—————} \textcircled{5}$$

by considering instant of explosion

P.C.L.M.  $2m V_0 = m \cdot V + m \cdot 0$

$$V = 2V_0 = 2\sqrt{ga} \quad \text{—————} \textcircled{5}$$

Velocity of Q is doubled



Using  $\Delta RSU$

$$\tan \theta = \frac{US}{RS}$$

$$g = \frac{V'}{t_2 + t_3}$$

$$V' = g(t_2 + t_3) \quad \text{---} \quad \textcircled{5}$$

$\Delta RQV$

$$\tan \theta = \frac{VQ}{RQ}$$

$$g = \frac{V''}{t_2}$$

$$V'' = gt_2 \quad \text{---} \quad \textcircled{5}$$

$$\textcircled{1}, \textcircled{2} \Rightarrow 9a = (t_2 + t_3) g(t_2 + t_3)$$

$$t_2 + t_3 = \sqrt{\frac{9a}{g}} \quad \text{---} \quad \textcircled{5}$$

(i). If the height to  $P$  from ground is  $h$ , when  $Q$  is reached to its highest point.

$$h = (\uparrow \text{ distance travelled by A } ) - \left( \begin{array}{c} \downarrow \text{ distance travelled by P,} \\ \text{after the explosion, till Q reaches its highest point} \end{array} \right)$$

$$= (\text{OABR area}) - (\text{RQV area})$$

$$= \frac{9a}{2} - \frac{1}{2} (RQ)(QV)$$

$$= \frac{9a}{2} - \frac{1}{2} t_2 \cdot V'' \quad \text{---} \quad \textcircled{5}$$

$$= \frac{9a}{2} - \frac{1}{2} t_2 g t_3$$

$$= \frac{9a}{2} - \frac{1}{2} g 4 \frac{a}{g}$$

$$= \frac{5a}{2} \quad \text{---} \quad \textcircled{5}$$

$$T = t_1 + t_2 + t_3 \quad \text{---} \quad \textcircled{5}$$

$$= \sqrt{\frac{a}{g}} (\sqrt{10} + 2) \quad \text{---} \quad \textcircled{5}$$

- (b) Velocity of a helicopter in still air is  $u \text{ km h}^{-1}$ . The points A, B and C are on level ground such that  $\hat{ACB} = \pi/2$ ,  $AB = d \text{ km}$  and  $AC = BC$ . In a certain day, the helicopter flies uniformly from A to B and then B to C and again C to A without stopping while a wind is blowing due BA direction with uniform velocity  $V \text{ km h}^{-1}$ , ( $v < u$ ). The time taken by helicopter to turn at each point B & C are negligible.

Find the time taken by helicopter to complete the journey ABCA.

Explain with reasons that, what will happen to the first  $A \rightarrow B$  part of the journey, when,

- (i).  $V = U$   
 (ii).  $V > U$

Answer -

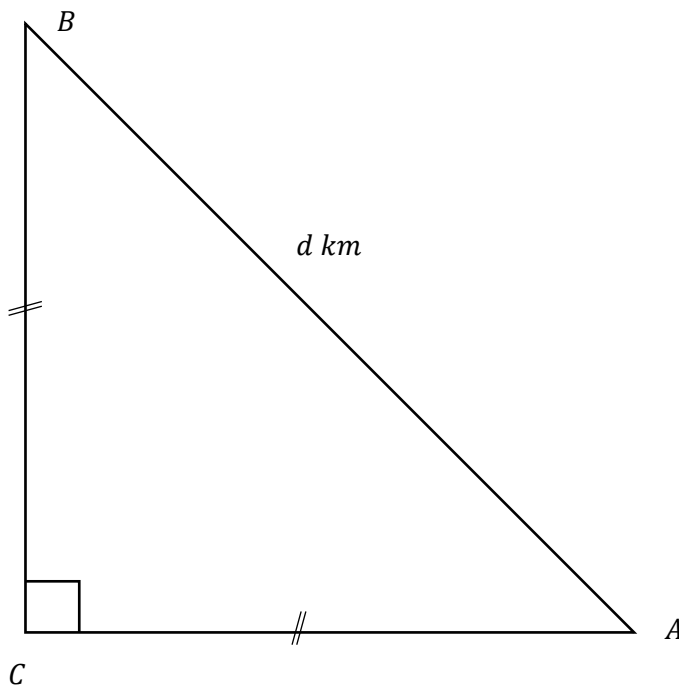

H - Helicopter

W - Wind

E - Earth

by using relative velocity principle,

$$(H, E) = (H, W) + (W, E)$$

$$\begin{aligned} \overset{\curvearrowright}{\textcircled{1}} \quad \overset{\downarrow}{\textcircled{2}} \quad \overset{\rightarrow}{\textcircled{3}} &= u + \begin{array}{c} \text{---} \pi/4 \text{---} \\ \searrow \\ v \end{array} \quad \text{---} \textcircled{10} \\ &= \begin{array}{c} \text{---} \pi/4 \text{---} \\ \searrow \\ v + u \end{array} \end{aligned}$$

PAPERMASTER.LK



$$\textcircled{1}^2 + \textcircled{2}^2 \Rightarrow u^2 \cos^2 \theta + u^2 \sin^2 \theta = \left(W_2 - \frac{v}{\sqrt{2}}\right)^2 + \left(\frac{v}{\sqrt{2}}\right)^2$$

$$\therefore u^2 = W_2^2 - \sqrt{2}V W_2 + V^2$$

$$\therefore W_2^2 - \sqrt{2}V W_2 + (V^2 - u^2) = 0$$

$$\therefore W_2 = \frac{\sqrt{2}V \pm \sqrt{(\sqrt{2}V)^2 - 4.1.(V^2 - u^2)}}{2.1}$$

$$= \left(\frac{\sqrt{2}V \pm \sqrt{4u^2 - 2V^2}}{2}\right)$$

$$W_2 > U > V > 0 \text{ and } W_2 = W_3$$

$$W_2 = W_3 = \left(\frac{\sqrt{2}V + \sqrt{4u^2 - 2V^2}}{2}\right) \text{ ————— } \textcircled{10}$$

$$\therefore t_2 = t_3 = \frac{BC}{PR_2} = \frac{d \cos(\pi/4)}{W_2}$$

$$= \frac{d}{\sqrt{2}} \frac{1}{\left(\frac{\sqrt{2}V + \sqrt{4u^2 - 2V^2}}{2}\right)} \text{ ————— } \textcircled{5}$$

$$= \left(\frac{d}{V + \sqrt{2u^2 - V^2}}\right)$$

$\therefore (A \rightarrow B), (B \rightarrow C), (C \rightarrow A)$  The time  $T$  to the entire motion.

$$T = t_1 + t_2 + t_3 = t_1 + 2t_2$$

$$= \frac{d}{(U - V)} + \frac{2d}{(V + \sqrt{2u^2 - V^2})} \text{ // ————— } \textcircled{5}$$

(i) If  $U = V$

$$\text{then } t_1 = \frac{d}{u - u} = \frac{d}{0} \rightarrow \infty \text{ ————— } \textcircled{5}$$

Then the time to journey from A to B is infinite. ie the velocity of helicopter with relative to the earth is,  $U - V = 0$ .  $\therefore$  The helicopter can't fly from A to B.

$\textcircled{5}$

(ii) If  $V > U$

then  $t_1 = \frac{d}{u-v}, V > U \therefore t_1 < 0$  this also can't happen. ————— (5)

ie then the velocity of H relative to earth in journey ( $A \rightarrow B$ ),  $(u - v) < 0$ . Then the velocity does not due ( $A \rightarrow B$ ). It is due ( $B \rightarrow A$ ).  $\therefore$  H can't fly from A to B. ————— (5)

(12) (a). A smooth wedge of mass  $2m$  and angle at one vertex  $\theta$  is kept on a smooth inclined plane with one surface is touching the plane. Inclination of the plane is  $\theta$  to the horizontal. Upper surface of the wedge is horizontal. One end of a light inextensible string is attached to the upper edge of the surface of wedge which touches the inclined plane. The string passes over a small smooth pulley which is fixed at the top of the inclined plane and hangs a particle of mass  $3m$  at the others end.

Entire string is in a vertical plane which passes through the center of mass of the wedge.

Now the system is released from rest with a particle of mas  $m$  which is kept on the line of intersection of the upper horizontal surface of wedge and the vertical plane though the centre of mass of wedge.

Then the wedge starts to move with a constant acceleration which is  $\frac{2}{7}$  of gravity, in magnitude, along the upward direction of the inclined plane.

Show that  $\theta = \pi/6$

After moving in a time period  $t$ , the particle of mass  $m$ , which is on the upper horizontal surface of wedge removes from the surface without any impulse and starts to move under gravity.

Does the particle  $m$  release from surface horizontally with relative to earth. Justify your answer.

Show that the ratio of accelerations of wedge before and after  $m$  releases it, is 5:7

Answer -

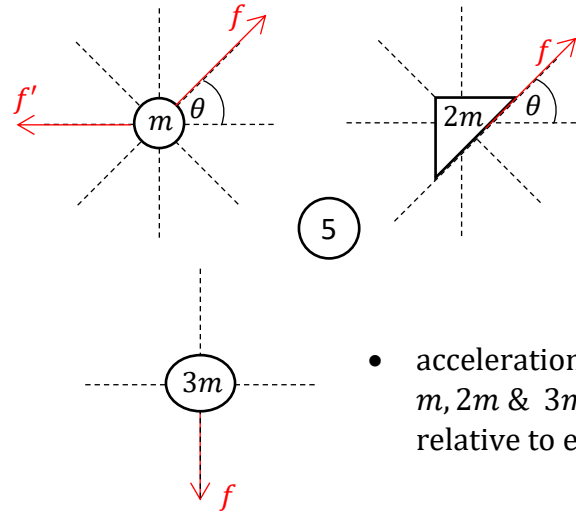
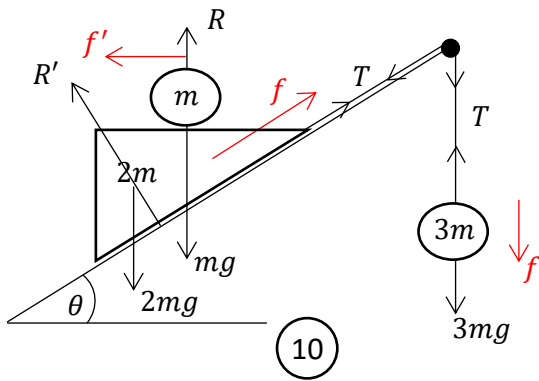

- accelerations of  $m, 2m$  &  $3m$  with relative to earth.

applying  $\underline{F} = m\underline{a}$

$$\textcircled{m}, \leftarrow \Rightarrow 0 = m(f' - f \cos \theta) \quad \text{---} \quad \textcircled{5}$$

$$\therefore f' = f \cos \theta \quad \text{---} \quad \textcircled{1}$$

$$\textcircled{m} + \textcircled{2m}, \nearrow_{\theta} \Rightarrow T - mg \sin \theta - 2mg \sin \theta = m(f - f' \cos \theta) + 2mf \quad \text{---} \quad \textcircled{2} \quad \text{---} \quad \textcircled{5}$$

$$\textcircled{3m}, \downarrow \Rightarrow 3mg - T = 3mf \quad \text{---} \quad \textcircled{3} \quad \text{---} \quad \textcircled{5}$$

$$\textcircled{1} + \textcircled{2} \Rightarrow 3g - 3g \sin \theta = 6f - f' \cos \theta$$

$$\textcircled{1} \Rightarrow f' = f \cos \theta$$

$$\therefore 3g - 3g \sin \theta = 6f - f \cos^2 \theta$$

$$\text{When } f = \frac{2}{7}g \rightarrow 3g - 3g \sin \theta = (6 - \cos^2 \theta) \frac{2}{7}g \quad \text{---} \quad \textcircled{5}$$

$$21 - 21 \sin \theta = 12 - 2 \cos^2 \theta$$

$$9 - 21 \sin \theta = -2(1 - \sin^2 \theta)$$

$$2 \sin^2 \theta + 21 \sin \theta - 11 = 0 \quad \text{---} \quad \textcircled{5}$$

$$(2 \sin \theta - 1)(\sin \theta + 11) = 0$$

$$\sin \theta \neq -11, \therefore 2 \sin \theta - 1 = 0$$

$\textcircled{5}$

$$\sin \theta = \frac{1}{2}$$

$$\sin \theta = \sin \frac{\pi}{6}$$

$$\theta = \frac{\pi}{6} \quad \text{---} \quad \textcircled{5}$$



Consider the acceleration components of (m) when it releases from wedge. (relative to earth)

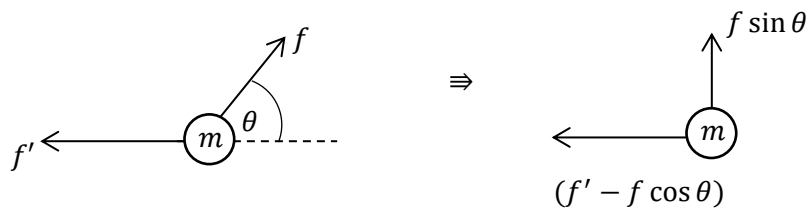

When  $\theta = \pi/6$ ,  $f = \frac{2}{7}g$ , by (1)

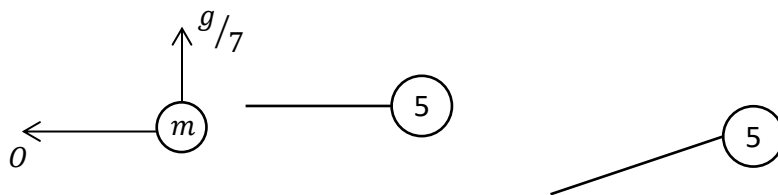

(m) does not come out from wedge horizontally, where it is released from wedge its horizontal acceleration component relative to earth is zero. At that instant it has a vertical acceleration component  $g/7$  relative to earth.

$\therefore$  It releases from wedge towards the vertically upward direction. ————— (5)

After (m) comes out from wedge

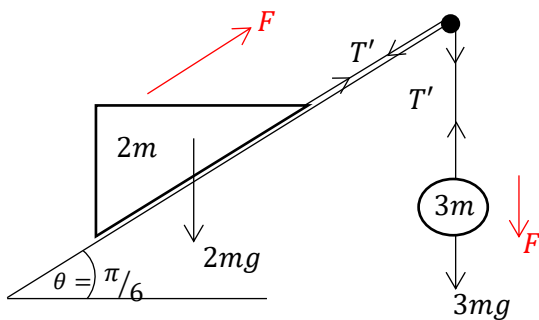

$$F = ma$$

$$\begin{aligned} (3m) \quad \downarrow \Rightarrow 3mg - T' &= 3mF \quad \text{--- (5)} \\ (2m) \quad \nearrow \Rightarrow T' - 2mg \cos(\pi/3) &= 2mF \quad \text{--- (5)} \end{aligned}$$

$$2mg = 5mF$$

$$F = \frac{2}{5}g \quad //$$

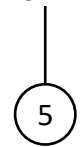

$\therefore$  Ratio of accelerations of wedge, before and after m releases,

$$\begin{aligned} f : F &= \frac{2}{7}g : \frac{2}{5}g \quad \text{--- (5)} \\ &= 5 : 7 \quad // \end{aligned}$$

(b) A particle  $P$  is projected under gravity of a point  $O$  on the horizontal ground with initial velocity  $\sqrt{48gh}$  at an inclination  $\pi/3$  to the horizontal. When  $P$  reaches to the highest point of its path it combines with another particle  $Q$  of same mass at rest which was at that highest point. The particle  $Q$  was hanging from a light inextensible string of length  $l$  from the fixed point  $O'$ .  $l = 3h$ . Let the combined particle as  $R$ .

- Find the velocity with which  $R$  starts to move.
- Let the velocity of  $R$  when  $O'R$  makes an angle  $\theta$  with vertical is  $W$ , and the tension in the string is  $T$ ,

Show that,

$$W^2 = 3gh (2 \cos \theta - 1)$$

$$T = 2mg (3 \cos \theta - 1)$$

If the particle  $R$  falls under gravity, instantly from the string, when  $O'R$  makes an angle  $\pi/3$  with vertical,

Find,

- Hight from  $O$  to the particle  $R$  when it falls from string.
- Horizontal distance from  $O$  to the point at which  $R$  hits on the ground.

Answer -

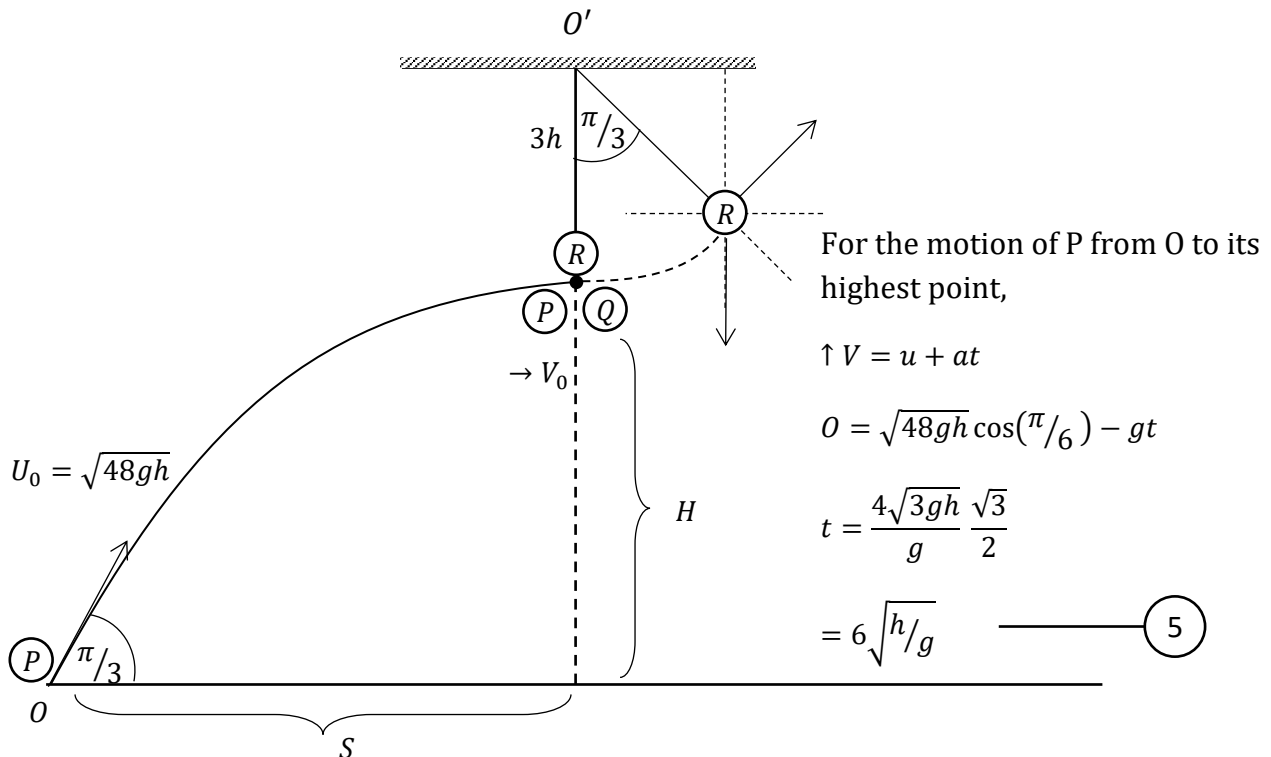

By considering the motion of P under gravity, from O to its highest point

$$\rightarrow S = ut + \frac{1}{2}at^2$$

$$S = U_0 \cos(\pi/3) t$$

$$= \sqrt{48gh} \frac{1}{2} t = 12\sqrt{3}h //$$

5

$$\rightarrow V = u + at$$

$$V_0 = U_0 \cos(\pi/3) + 0$$

$$V_0 = \sqrt{48gh} \frac{1}{2}$$

$$V_0 = 2\sqrt{3gh} //$$

5

$$\uparrow V^2 = u^2 + 2as$$

$$0 = [U_0 \sin(\pi/3)]^2 - 2gH$$

$$[\sqrt{48gh} \cdot \sqrt{3}/2]^2 = 2gH$$

$$48gh \cdot \frac{3}{4} = 2gH$$

$$H = 18h$$

5

by considering the collision



→ principle of conservation of linear momentum

$$2m \cdot V = m \cdot V_0 + m \cdot 0$$

$$V = \frac{V_0}{2}$$

5

=  $\sqrt{3gh}$  ← R Velocity with which R starts to move. //

By considering the two instances - at which R starts the motion and at which  $O'R$  makes and angle  $\pi/3$  with the vertical - applying the principle of conservation of mechanical energy

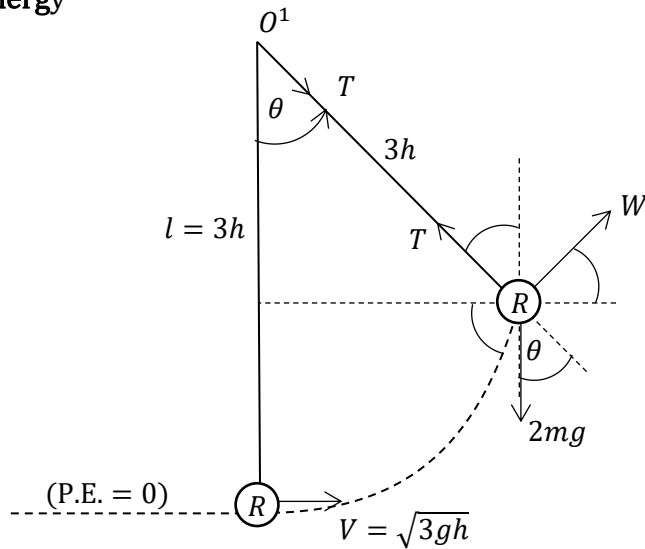

$$E_2 = E_1$$

$$(\text{K.E.} + \text{P.E.})_1 = (\text{K.E.} + \text{P.E.})_2$$

$$\frac{1}{2}(2m)V^2 + 0 = \frac{1}{2}(2m)W^2 + (2m)g(3h - 3h \cos \theta)$$

$$V^2 = W^2 + 2g(3h - 3h \cos \theta)$$

$$3gh = W^2 + 6gh - 6gh \cos \theta$$

$$W^2 = 6gh \cos \theta - 3gh \quad \text{--- (5)}$$

$$\curvearrowright F = ma$$

$$T - 2mg \cos \theta = 2m \left( \frac{W^2}{3h} \right) \quad \text{--- (10)}$$

$$\begin{aligned} T &= \frac{2m}{3h} \cdot 3gh(2 \cos \theta - 1) + 2mg \cos \theta \\ &= 2mg(2 \cos \theta - 1) + 2mg \cos \theta \quad \text{--- (5)} \\ &= 2mg(3 \cos \theta - 1) // \end{aligned}$$

When R releases from string at  $\theta = \pi/3$ , velocity.

$$W^2 = 3gh(2 \cos \theta - 1)$$

$$\theta = \frac{\pi}{3} \rightarrow W^2 = 3gh[2 \cos \frac{\pi}{3} - 1]$$

$$W = 0 // \quad \text{--- (5)}$$

(i). If the height from O to R at this instance is  $H_0$

$$\begin{aligned} H_0 &= H + 3h - 3h \cos \frac{\pi}{3} \\ &= 18h + \frac{3h}{2} = \frac{39}{2}h // \quad \text{--- (5)} \end{aligned}$$

(ii). Velocity,  $W = 0$  where R releases from string  $\therefore$  The released R starts to move vertically downwards under gravity.

If the distance from O to the point at which T hits on the ground is d,

$$d = S + 3h \cos(\pi/6) = 12\sqrt{3}h + 3h \frac{\sqrt{3}}{2} = \frac{27}{2}\sqrt{3}h // \quad \text{--- (5)}$$

(13). Two ends of a light elastic spring of natural length  $3a$  are A and B. The spring is vertically fixed at the end A on a horizontal plane. When a particle P of mass  $2m$  is kept at rest its upper end B, the length of the spring is  $2a$ .

Show that the modulus of elasticity of the spring is  $6mg$ .

Now the particle P is released at rest from the point,  $4a$  vertically above A.

Show that the minimum length of the spring during the subsequent motion, is  $(2 - \sqrt{3})a$ .

Show that the time period from the starting point of P to the instant at which the spring comes its minimum length for the first time is,

$$\sqrt{\frac{a}{g}} \left\{ \sqrt{2} + \frac{\pi}{2} + \sin^{-1}\left(\frac{1}{\sqrt{3}}\right) \right\}$$

At the above instant at which the spring has its minimum length a part of mass  $m$  falls from P without any collision with spring.

How long does the remaining mass  $m$  remain on the end A of the spring with touching it.

Answer -

Finding  $\lambda$

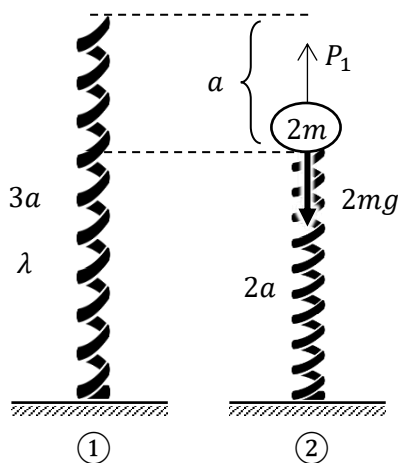

In this incident there exist two S.H.M.S with masses  $2m$  &  $m$ .  $\therefore$  We have to show that there exist two S.H.M & have to find  $\omega_1$  &  $\omega_2$  W.R.T. those S.H.M. And also the two centres.

figure (2)

$$\uparrow = \downarrow$$

$$P_1 = 2mg$$

$$\frac{a}{3a} \lambda = 2mg \quad \text{--- (10)}$$

$$\lambda = 6mg //$$

PAPERMASTER.LK

figure ③

$$\downarrow F = ma$$

$$2mg - P_2 = 2m \ddot{x} \quad \text{--- ⑩}$$

$$2mg - \left(\frac{a+x}{3a}\right) 6mg = 2m \ddot{x}$$

$$2g - 2g - \frac{2g}{a}x = 2 \ddot{x}$$

$$\ddot{x} + \left(\sqrt{\frac{g}{a}}\right)^2 x = 0 \quad \text{--- ⑤}$$

This is of the form  $\ddot{x} + \omega^2 x = 0$

∴ the motion of  $2m$  (after touching the spring) is a S. H. M.  $\omega_1 = \sqrt{g/a}$  --- ⑤

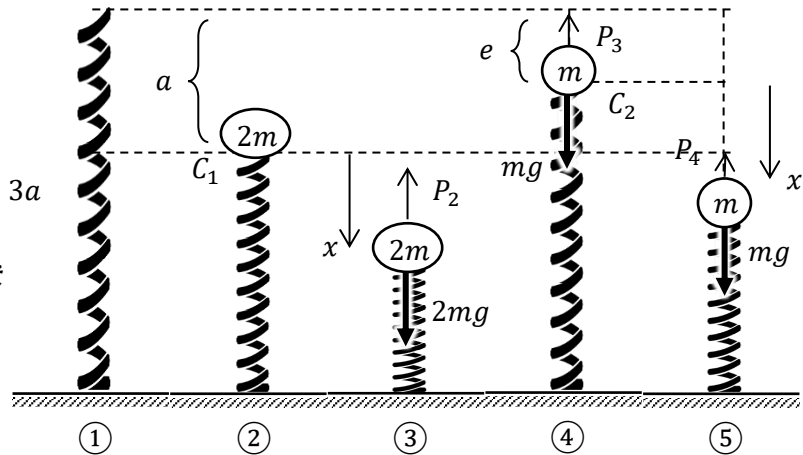

figure ④

$$\uparrow = \downarrow$$

$$P_3 = mg$$

$$\frac{e}{3a} 6mg = mg$$

$$e = a/2 \quad \text{--- ⑤}$$

$$\downarrow F = ma$$

$$mg - P_4 = m \ddot{x} \quad \text{--- ⑩}$$

$$mg - \frac{\left(\frac{a}{2} + x\right)}{3a} 6mg = m \ddot{x}$$

$$g - g - \frac{2g}{a}x = \ddot{x}$$

$$\ddot{x} + \left(\sqrt{\frac{2g}{a}}\right)^2 x = 0 \quad \text{--- ⑤}$$

This is of the form  $\ddot{x} + \omega^2 x = 0$

∴ the motion of the particle  $m$  also a S. H. M. (during toching with spring)  $\omega_2 = \sqrt{2g/a}$  --- ⑤

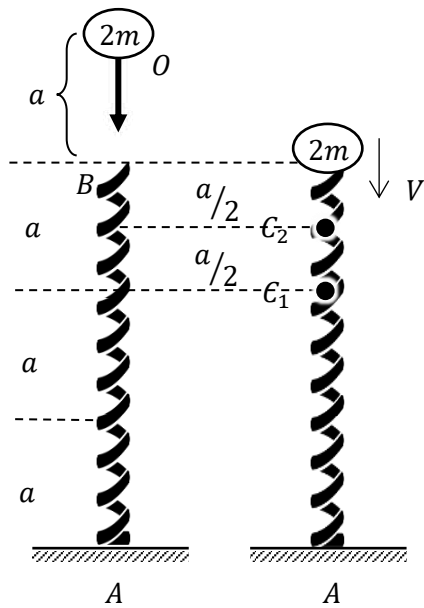

by considering the motion of  $2m$  under gravity, till it touches the spring.

$$\begin{aligned} \downarrow V^2 &= u^2 + 2as \\ V^2 &= 0 + 2ga \\ V &= \sqrt{2ga} \end{aligned} \quad \text{--- (5)}$$

$$\begin{aligned} \downarrow S &= ut + \frac{1}{2}at^2 \\ a &= 0 + \frac{1}{2}gt_0^2 \\ t_0 &= \sqrt{2a/g} \end{aligned} \quad \text{--- (5)}$$

by considering the instant at which  $2m$  touches the spring.

applying  $\dot{x}^2 = \omega^2(A^2 - x^2)$

$$V^2 = \omega_1^2(A_1^2 - a^2) \quad \text{--- (10)}$$

$$2ga = \frac{g}{a}(A_1^2 - a^2)$$

$$\Rightarrow A_1 = \sqrt{3}a \quad \text{--- (5)}$$

$\therefore$  After  $2m$  touches (drops) the spring - till it comes to instantaneous rest it moves a distance  $A_1$  downward from center  $C_1$ . Spring has its minimum length at this instant.

$$\therefore \text{minimum length of spring} = 2a - A_1 \quad \text{--- (5)}$$

$$= 2a - \sqrt{3}a$$

$$= (2 - \sqrt{3})a \quad \text{--- (5)}$$

By considering the initial gravitational motion of  $2m$ , till it touches the spring - the time period.

$$t_o = \sqrt{2a/g} \text{ (previously obtained)}$$

Now by considering the S.H.M. from the instant  $2m$  touches the spring to the instant that spring has its minimum length.

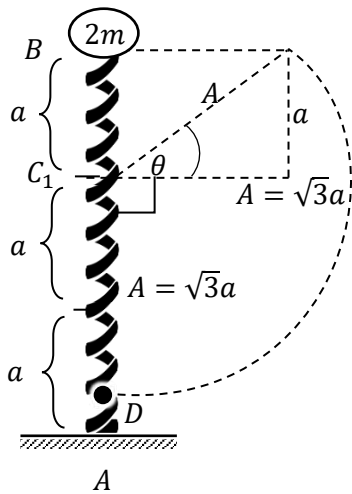

applying  $\theta = \omega t$

$$t = \left( \frac{\theta + \pi/2}{\omega_1} \right) \text{ --- (5)}$$

$$= \frac{1}{\sqrt{g/a}} \left( \frac{\pi}{2} + \theta \right)$$

$$= \sqrt{\frac{a}{g}} \left[ \frac{\pi}{2} + \sin^{-1} \left( \frac{1}{\sqrt{3}} \right) \right] \text{ --- (5)}$$

$$\sin \theta = \frac{a}{A}$$

$$= a/\sqrt{3}a \text{ (5)}$$

$$\therefore \theta = \sin^{-1} \left( \frac{1}{\sqrt{3}} \right)$$

$\therefore$  If the time period is  $T_1$  form starting point to the minimum length point

$$T_1 = t_o + t$$

$$= \sqrt{\frac{2a}{g}} + \sqrt{\frac{a}{g}} \left[ \frac{\pi}{2} + \sin^{-1} \left( \frac{1}{\sqrt{3}} \right) \right] \text{ --- (10)}$$

$$= \sqrt{\frac{a}{g}} \left\{ \sqrt{2} + \frac{\pi}{2} + \sin^{-1} \left( \frac{1}{\sqrt{3}} \right) \right\} //$$

Now, when a mass of  $m$  falls from  $2m$  - at the minimum length of spring.

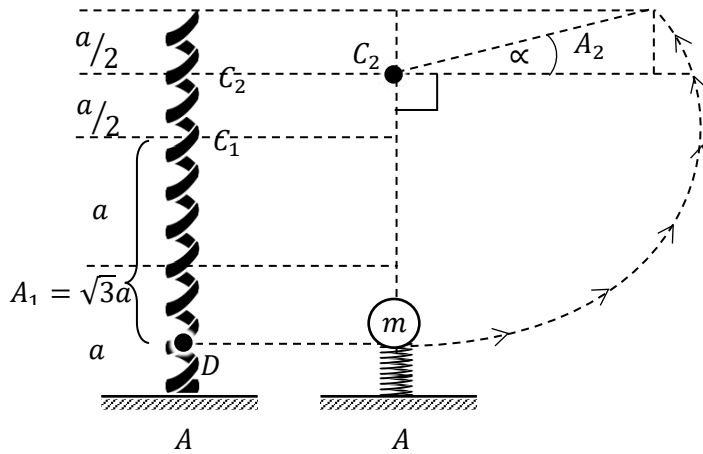

at lowest position  $D$

$$\dot{x}^2 = w^2(A^2 - x^2)$$

$$0 = \omega_2^2[A_2^2 - (C_2D)^2] \Rightarrow A_2 = [C_2D] \quad \text{--- (10)}$$

$$\therefore A_2 = \frac{a}{2} + \sqrt{3}a = \frac{a}{2}(1 + 2\sqrt{3}) \quad \text{--- (5)}$$

The remaining mass  $m$  remains on the spring till the spring comes to its natural length again.

from figure

$$\sin \alpha = \left( \frac{a/2}{A_2} \right)$$

$$= \frac{a/2}{\frac{a}{2}(1 + 2\sqrt{3})}$$

$$= \frac{1}{(1 + 2\sqrt{3})}$$

$$= \frac{(2\sqrt{3} - 1)}{(2\sqrt{3} + 1)(2\sqrt{3} - 1)}$$

$$= \left( \frac{2\sqrt{3} - 1}{11} \right) \quad \text{--- (10)}$$

using  $\theta = wt$

the time period in which remaining mass  $m$  remains on spring,

$$t = \frac{\theta}{w}$$

$$t = \left( \frac{\pi/2 + \alpha}{w_2} \right)$$

$$= \sqrt{\frac{a}{2g}} \left[ \frac{\pi}{2} + \sin^{-1} \left( \frac{2\sqrt{3} - 1}{11} \right) \right] \quad \text{// --- (10)}$$

14.

- (a).  $OACB$  is a parallelogram where  $O$  is the vector origin. The points  $P, Q, R$  and  $S$  are on the sides  $OA, AC, CB$  and  $BO$  respectively such that,

$$OP:OA = AQ:AC = CR:CB = BS:BO = 1:3$$

$\underline{a}$  and  $\underline{b}$  are the position vectors of  $A$  &  $B$  respectively with relative to origin.

- (i) Writedown the position vectors of  $P, Q, R$  and  $S$  in terms of  $\underline{a}$  and  $\underline{b}$

- (ii) Show that  $PQRS$  is a parallelogram.

- (iii) if

$$\theta = \cos^{-1} \frac{2(|\underline{a}|^2 - |\underline{b}|^2)}{3|\underline{a}||\underline{b}|} \text{ where } \widehat{AOB} = \theta$$

Show that  $PQRS$  is a rectangle.

- (b). The forces  $P_1, P_2, P_3$  are acting at the points  $A, B, C$  on oxy plane, respectively.

where  $A \equiv (3a, -2a)$

$$P_1 = -P\underline{i} + 3P\underline{j}$$

$$B \equiv (-a, -3a)$$

$$P_2 = 2P\underline{i} + 4P\underline{j}$$

$$C \equiv (2a, 5a)$$

$$P_3 = 3P\underline{i} - 2P\underline{j} \text{ } \odot \odot.$$

( $\underline{i}, \underline{j}$ , are in usual notation)

$a, \lambda, \mu$  are positive quantities,  $a$ - measured in meters and  $P$  in newtons.

Show that the clockwise moment of the system about origin  $O$  is  $10Pa \text{ N m}$ .

Now an extra force  $P_4 = (\lambda P\underline{i} + \mu P\underline{j})$  is added to the system which is acting at the point  $D (\lambda a, \mu a)$

Show that there is no change in moment about origin  $O$ .

Now let the resultant of the system of forces  $P_1, P_2, P_3$  and  $P_4$  is a single force  $R$  which is acting at  $E(O, \mu)$ . The line of action of  $R$  makes an angle  $\pi/3$  counterclockwise with the positive direction of  $ox$  axis.

Writedown the magnitude of  $R$ .

Determine the values of  $\lambda$  and  $\mu$ .



if the parallelogram  $PQRS$  is a rectangle.

$PS \perp PQ$  condition should be satisfied.

$\vec{PS} \perp \vec{PQ}$

$$\therefore \vec{PS} \cdot \vec{PQ} = 0 \quad \text{—————} \textcircled{5}$$

$$\left( \begin{array}{l} \vec{PS} = \vec{PO} + \vec{OS} \\ = -\frac{1}{3}\underline{a} + \frac{2}{3}\underline{b} \end{array} \right), \left( \begin{array}{l} \vec{PQ} = \vec{PA} + \vec{AQ} \\ = \frac{2}{3}\underline{a} + \frac{1}{3}\underline{b} \end{array} \right)$$

Now if  $\vec{PS} \cdot \vec{PQ} = 0$

$$\left(-\frac{1}{3}\underline{a} + \frac{2}{3}\underline{b}\right) \cdot \left(\frac{2}{3}\underline{a} + \frac{1}{3}\underline{b}\right) = 0$$

$$-\frac{2}{9}(\underline{a} \cdot \underline{a}) + \frac{2}{9}(\underline{b} \cdot \underline{b}) + \frac{3}{9}(\underline{a} \cdot \underline{b}) = 0 \quad \text{—————} \textcircled{5}$$

$$-2|\underline{a}| |\underline{a}| \cos 0 + 2|\underline{b}| |\underline{b}| \cos 0 + 3|\underline{a}| |\underline{b}| \cos \theta = 0$$

(where  $\theta$  is the angle between  $\underline{a}$  and  $\underline{b}$ )

$$\therefore 3|\underline{a}| |\underline{a}| \cos \theta = 2|\underline{a}|^2 - 2|\underline{b}|^2 \quad \text{—————} \textcircled{5}$$

$$\cos \theta = \frac{2(|\underline{a}|^2 - |\underline{b}|^2)}{3|\underline{a}| |\underline{b}|}$$

$$\therefore \text{if } \theta = \cos^{-1} \frac{2(|\underline{a}|^2 - |\underline{b}|^2)}{3|\underline{a}| |\underline{b}|} \text{ then } \vec{PS} \cdot \vec{PQ} = 0$$

$\therefore$  then  $PS \perp PQ$

$\therefore$  the parallelogram  $PQRS$  is a rectangle. —————  $\textcircled{5}$

(b) Answer -

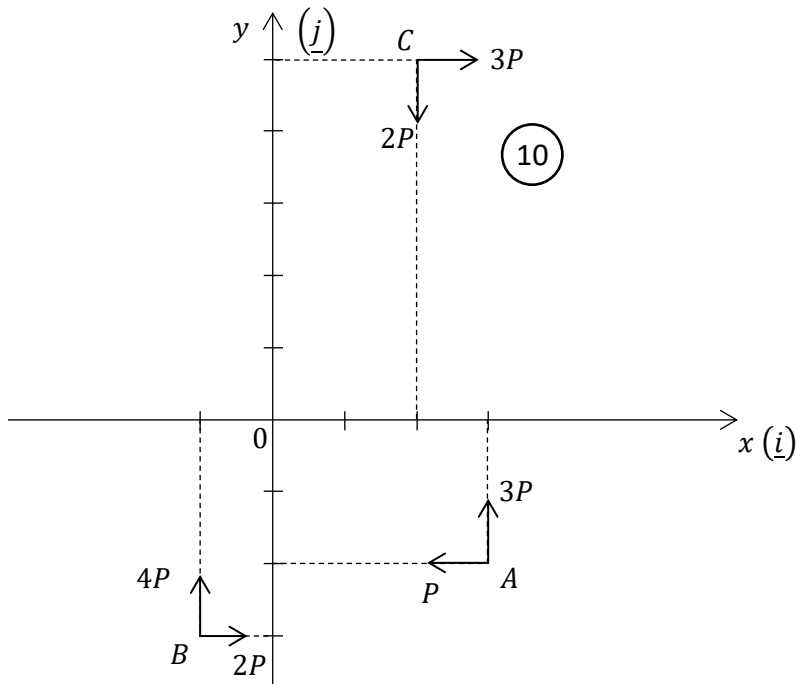

$$\begin{aligned} \widehat{O}L &= (P)(2a) - (3P)(3a) - (2P)(3a) + (4P)(a) + (3P)(5a) + (2P)(2a) \quad \text{--- (10)} \\ &= 2Pa - 9Pa - 6Pa + 4Pa + 15Pa + 4Pa \\ &= 10Pa \text{ N m} \quad // \quad (\text{moment of system about } O) \end{aligned}$$

❖ Now consider the new  $P_4$  force only.

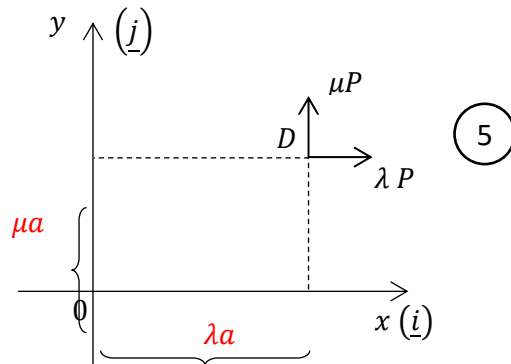

$$\begin{aligned} \text{Clockwise moment of } P_4 \text{ about } O &= (\lambda P)(\mu a) - (\mu P)(\lambda a) \\ &= \lambda \mu Pa - \lambda \mu Pa \\ &= 0 \quad \text{--- (5)} \end{aligned}$$

∴ There is no change in moment even though the fourth  $P_4$  is added. //

Now consider the new system.

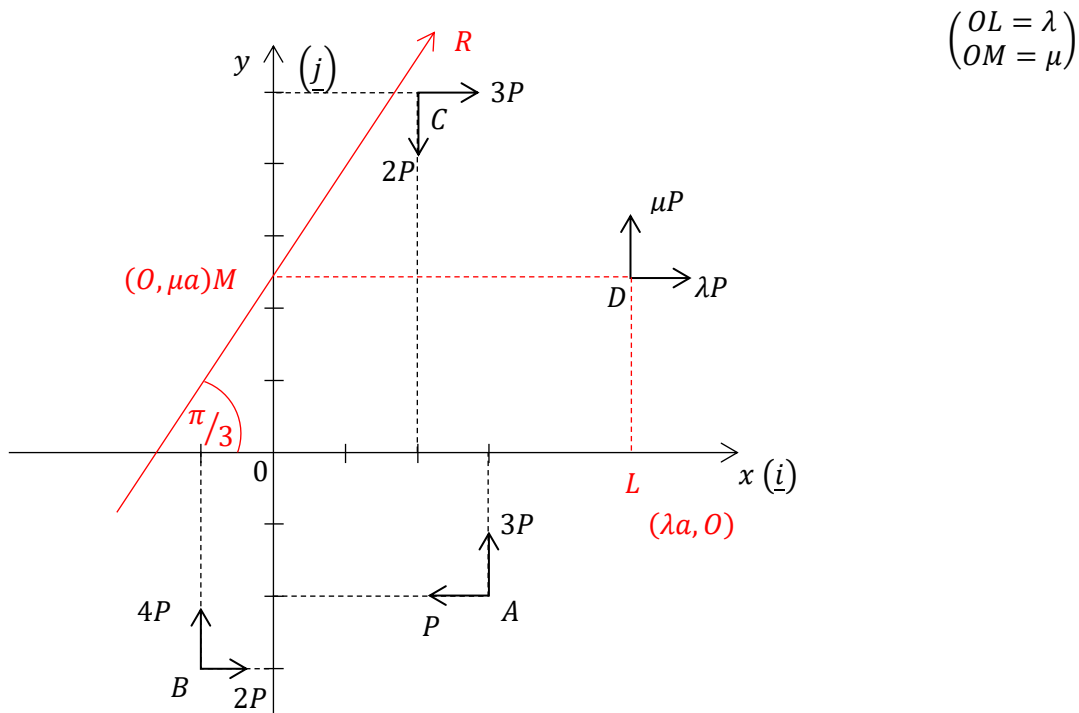

Resultant of the Entire system

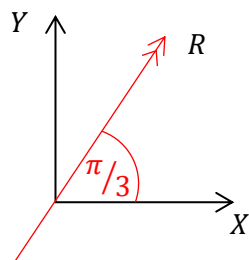

$$\begin{aligned} \vec{X} &= -P + 2P + 3P + \lambda P \\ &= (4 + \lambda)P \quad \text{--- (5)} \end{aligned}$$

$$\begin{aligned} \uparrow Y &= 3P + 4P - 2P + \mu P \\ &= (5 + \mu)P \quad \text{--- (5)} \end{aligned}$$

$$\begin{aligned} R &= \sqrt{X^2 + Y^2} \\ &= \sqrt{(4 + \lambda)^2 P^2 + (5 + \mu)^2 P^2} \\ &= P\sqrt{\lambda^2 + \mu^2 + 8\lambda + 10\mu + 41} \quad N \quad \text{--- (5)} \end{aligned}$$

$$\tan(\pi/3) = \frac{Y}{X} = \sqrt{3} \quad \text{--- (5)}$$

$$Y = \sqrt{3}X$$

$$(5 + \lambda)P = \sqrt{3}(4 + \lambda)P$$

$$5 + \mu = 4\sqrt{3} + \sqrt{3}\lambda \quad \text{--- (1) --- (5)}$$

As the resultant is passing through  $M(0, \mu)$

$$M_L = 0$$

PAPERMASTER.LK



$$P(2a + \mu a) - 3p(3a) + 4P(a) - 2P(3a + \mu a) + 2P(2a) + 3P(5a - \mu a) - \mu P(\lambda a) = 0$$

$$(2a + \mu a) - 9a + 4a - 2(3a + \mu a)4a + 3(5a - \mu a) - \lambda \mu a = 0$$

10

$$10 - 4\mu - \lambda\mu = 0 \text{ --- (2) --- (5)}$$

$$\textcircled{1} \Rightarrow \lambda = \left( \frac{5 + \mu - 4\sqrt{3}}{\sqrt{3}} \right)$$

$$\textcircled{2} \Rightarrow \lambda = \left( \frac{10 - 4\mu}{\mu} \right)$$

$$\therefore \frac{5 + \mu - 4\sqrt{3}}{\sqrt{3}} = \frac{10 - 4\mu}{\mu}$$

$$5\mu + \mu^2 - 4\sqrt{3}\mu = 10\sqrt{3} - 4\sqrt{3}\mu$$

$$\mu^2 + 5\mu - 10\sqrt{3} = 0 \text{ --- (5)}$$

$$\mu = \frac{-5 \pm \sqrt{25 - 4(-10\sqrt{3})}}{2}$$

$$\mu = \frac{-5 \pm \sqrt{25 + 40\sqrt{3}}}{2} \text{ --- (5)}$$

$\mu > 0$  as

$$\mu = \left( \frac{\sqrt{25 + 40\sqrt{3}} - 5}{2} \right) // \text{ --- (5)}$$

$\textcircled{1} \Rightarrow$

$$\therefore \lambda = \frac{1}{\sqrt{3}} (5 + \mu - 4\sqrt{3})$$

$$= \frac{1}{\sqrt{3}} \left[ 5 - 4\sqrt{3} + \frac{\sqrt{25 + 40\sqrt{3}} - 5}{2} \right]$$

$$\lambda = \frac{1}{\sqrt{3}} \left[ \frac{10 - 8\sqrt{3} + \sqrt{25 + 40\sqrt{3}} - 5}{2} \right]$$

$$\lambda = \frac{1}{2\sqrt{3}} (5 - 8\sqrt{3} + \sqrt{25 + 40\sqrt{3}}) // \text{ --- (5)}$$



15.

- (a). One end of a uniform rod of length  $2\sqrt{3}r$  and weight  $2w$  is smoothly hinged to a fixed point P on a vertical wall. One end of a light inelastic string is attached to the other end of the rod. The other end of the string is attached to a fixed point on a ceiling so that the string is vertical and the rod is in equilibrium in a vertical plane which is perpendicular to the wall.

The rod makes an angle  $\pi/6$  with the upward vertical at P.

Now a thin smooth circular lamina of weight  $w$  and radius  $r$  is kept in equilibrium on the rod in the acute angled gap between the rod and the wall with touching both the rod and the wall, in a vertical plane.

Mark all the forces acting on the lamina and on the rod correctly in two separate diagrams.

Find the tension in the string and the resultant reaction acting on the rod at P.

Answer -

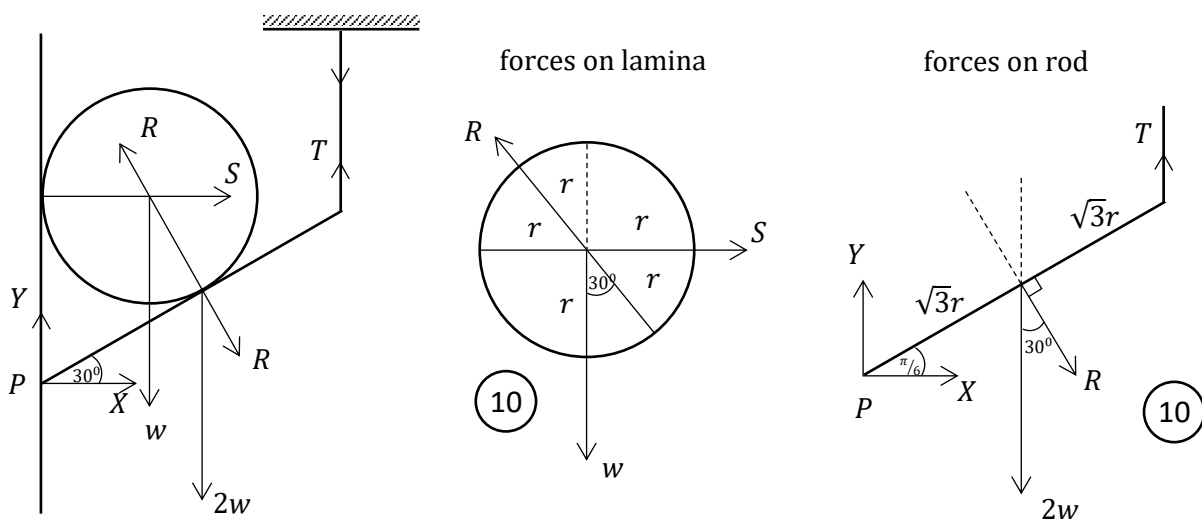

by considering the equilibrium of lamina

$$\uparrow = \downarrow \Rightarrow R \cos(\pi/6) = w$$

$$R = 2w/\sqrt{3} \quad // \quad \text{—————} \quad (5)$$

$$\rightarrow = \leftarrow \Rightarrow S = R \cos(\pi/3) \quad \text{—————} \quad (5)$$

$$= \frac{2w}{\sqrt{3}} \cdot \frac{1}{2} = w/\sqrt{3} \quad //$$

PAPERMASTER.LK

by considering the equilibrium of rod

$$\overset{\curvearrowright}{P} = \overset{\curvearrowright}{P} \Rightarrow (T) \cdot (2\sqrt{3}r \cos \pi/6) = (2w)(\sqrt{3}r \cos \pi/6) + (R)(\sqrt{3}r) \quad \text{—————} \textcircled{10}$$

$$T \cdot \frac{2\sqrt{3}}{2} = \frac{2w\sqrt{3}}{2} = \frac{2w}{\sqrt{3}}$$

$$T = 5w/\sqrt{3} \quad // \quad \text{—————} \textcircled{5}$$

$$\rightarrow = \leftarrow \Rightarrow X + R \cos(\pi/3) = 0 \quad \text{—————} \textcircled{5}$$

$$X = \frac{-2w}{\sqrt{3}} \cdot \frac{1}{2}$$

$$= -w/\sqrt{3} \quad // \quad \text{—————} \textcircled{5}$$

Horizontal component of reaction on rod at P from the wall, is towards the wall.

$$\vec{X} = w/\sqrt{3}$$

$$\uparrow = \downarrow \Rightarrow Y + T = 2w + R \cos(\pi/6) \quad \text{—————} \textcircled{5}$$

$$Y = 2w + \frac{2w}{\sqrt{3}} \cdot \frac{\sqrt{3}}{2} - \frac{5w}{3}$$

$$= \frac{4w}{3} \quad // \quad \text{—————} \textcircled{5}$$

∴ Components of forces acting on rod at P from the wall are as show in the figure

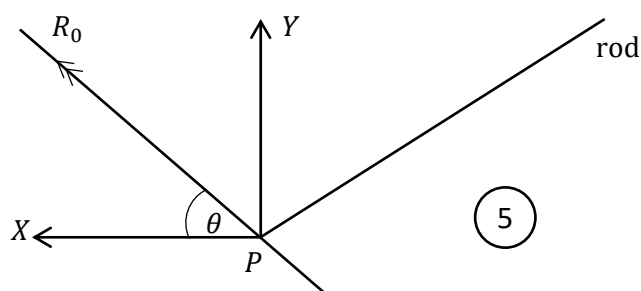

∴ Resultant reaction on rod at  $P$ .

$$\begin{aligned}
 R_0 &= \sqrt{X^2 + Y^2} \\
 &= \sqrt{\left(\frac{w}{\sqrt{3}}\right)^2 + \left(4\frac{w}{3}\right)^2} \quad \text{—————} \textcircled{5} \\
 &= w \sqrt{\frac{1}{3} + \frac{16}{9}} \\
 &= \frac{\sqrt{19}}{3} w \quad // \quad \text{—————} \textcircled{5}
 \end{aligned}$$

$$\begin{aligned}
 \tan \theta &= (Y/X) \\
 &= \left(\frac{4w/3}{w/\sqrt{3}}\right) = 4/\sqrt{3} \\
 \theta &= \tan^{-1}\left(4/\sqrt{3}\right) \quad \text{—————} \textcircled{5}
 \end{aligned}$$

The resultant reaction on rod at  $P$  from the wall is acting upward direction making an angle.  $\theta = \tan^{-1}\left(4/\sqrt{3}\right)$  with the upward vertical.

- (b). In the frame work which is shown in the figure  $PQ = 3a, QR = 4a$  and  $RS = 12a$ . It consists of five light rods  $Q, QR, PR, SR$  and  $SP$ .  $\widehat{PQR} = \widehat{PRS} = \pi/2$ . The frame work is smoothly hinged at a fixed point  $P$  and kept in equilibrium in a vertical plane. A weight  $1000\text{ N}$  at  $S$  and a vertically downward force  $F\text{ N}$  at  $Q$  are applied.

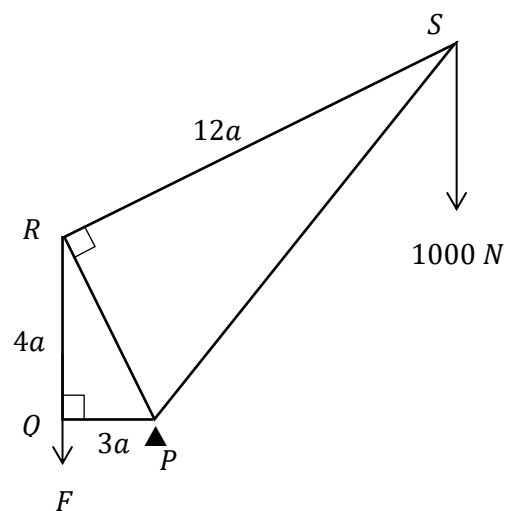

Find the magnitude of  $F$ .

Using **Bow's notation**, draw a stress diagram for the framework and find the stresses in all rods, distinguishing between tensions and thrusts.

Answer -

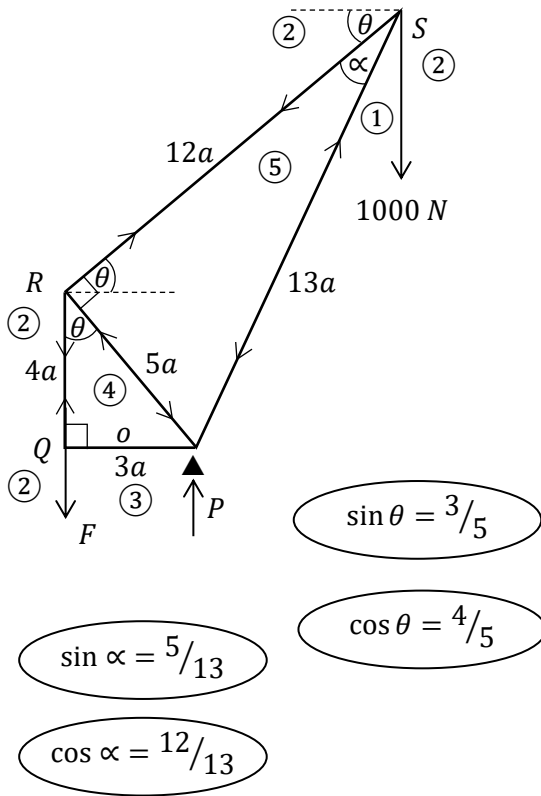

Taking moments about P, by considering the equilibrium of the system.

$$\overset{\curvearrowright}{P} = \overset{\curvearrowleft}{P}$$

$$F \cdot 3a = 1000(12a \cos \theta - 3a) \quad \text{--- (10)}$$

$$3F = 1000 \left( 12 \cdot \frac{4}{5} - 3 \right)$$

$$F = \frac{1000}{3} \left( \frac{33}{5} \right)$$

$$F = 2200 \text{ N} \quad \text{--- (5)}$$

Other than the reaction at P, the other two forces acting on the system are - F vertical force at Q and 1000 N at S only.

Both above two forces are vertical.  $\therefore$  The reaction at P should also be vertical.

$\therefore \uparrow = \downarrow$

$$P = F + 1000$$

$$P = 3200 \text{ N} \quad \text{--- (5)}$$

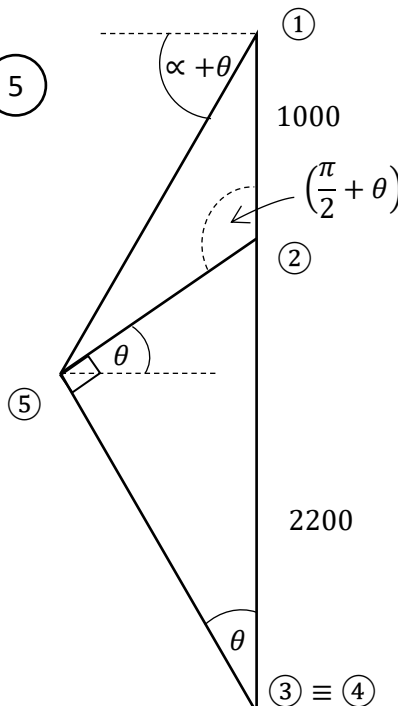

$$\begin{aligned} (4)(5) &= (4)(2) \cos \theta \\ &= (2200) \left( \frac{4}{5} \right) \\ &= 1760 \end{aligned}$$

$$\begin{aligned} (5)(2) &= (2)(4) \sin \theta \\ &= (2200) \left( \frac{3}{5} \right) \\ &= 1320 \end{aligned}$$

PAPERMASTER.LK



$$\textcircled{1} \textcircled{5} \cos(\alpha + \theta) = \textcircled{2} \textcircled{5} \cos \theta$$

$$\textcircled{1} \textcircled{5} [\cos \alpha \cos \theta - \sin \alpha \sin \theta] = 1320 \cdot \frac{4}{5}$$

$$\textcircled{1} \textcircled{5} \left[ \frac{12}{13} \cdot \frac{4}{5} - \frac{5}{13} \cdot \frac{3}{5} \right] = 1320 \cdot \frac{4}{5}$$

$$\textcircled{1} \textcircled{5} \left( \frac{48 - 15}{13} \right) = 1320(4)$$

$$\textcircled{1} \textcircled{5} = \frac{(1320)(4)(13)}{33} = \frac{(120)(4)(13)}{3} = 2080$$

Rod	Stress	
	tension	thrust
PQ	-----	-----
QR	$\textcircled{5}$ 2200 N $\textcircled{5}$	----- $\textcircled{5}$
RS	$\textcircled{5}$ 1320 N $\textcircled{5}$	-----
SP	-----	$\textcircled{5}$ 2080 N $\textcircled{5}$
PR	-----	$\textcircled{5}$ 1760 N $\textcircled{5}$

## 16.

- Show that the centre of mass of a uniform hollow hemisphere of radius  $a$  is on its axis of symmetry at a distance  $\frac{a}{2}$  from the centre of the base.
- The centre of mass of a uniform hollow right circular cone of height  $h$ , is on its axis of symmetry at a distance  $\frac{h}{3}$  from the centre of the base.

A uniform hollow hemisphere of radius  $2a$  and surface density  $\rho$  and, a right circular hollow cone of base radius  $\sqrt{3}a$ , semi-vertical angle  $\frac{\pi}{6}$  and surface density  $\sigma$  are fixed together as shown in the figure.

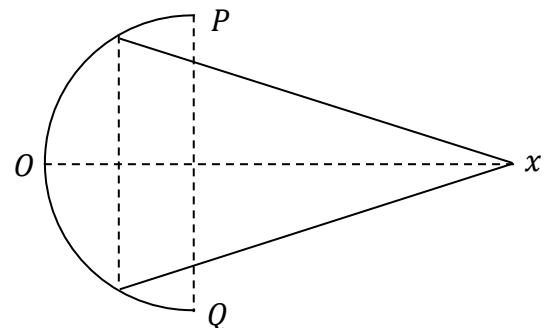

Edge of the circular base of hollow cone is attached to the inner surface of the hollow hemisphere so that the composite body has a same axis of symmetry.

Show that the distance to the centre of mass G of composite body, from O, along the axis of symmetry ox is

$$OG = 2 \frac{(2\rho + 3\sigma)}{(4\rho + 3\sigma)} a$$

The composite body is hanged freely from P at a fixed point by a light inextensible string. Then the axis of symmetry makes an angle  $\tan^{-1}(3)$  with the vertical when in its equilibrium position.

Show that  $\rho : \sigma = 3 : 2$

Now by joining an extra particle to the vertex of the cone, the composite body is kept in equilibrium so that the axis of symmetry of the composite body is horizontal.

Show that the mass of the extra particle is half of the mass of the hollow hemisphere.

Answer -

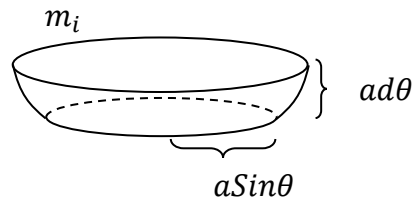
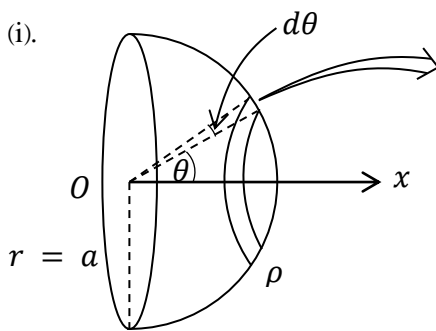

$$\begin{aligned} m_i &= A\rho, \text{ (surface density } \rho) \\ &= (2\pi r h)\rho, \text{ (as a hollow cylinder)} \\ &= 2\pi a \sin \theta \cdot a d\theta \rho \end{aligned}$$

$x_i$  – distance to the centre of mass of small  $m_i$  from  $O$  along  $OX$ .

$$x_i = a \cos \theta$$

If the distance to centre of mass of entire hollow hemisphere, from  $O$ , along  $OX$  is  $\bar{x}$ .

$$\begin{aligned} \bar{x} &= \frac{\int m_i x_i}{\int m_i} \\ &= \frac{\int_0^{\pi/2} 2\pi a \sin \theta \cdot a d\theta \rho \cdot a \cos \theta}{\int_0^{\pi/2} 2\pi a \sin \theta \cdot a d\theta \rho} \quad \begin{array}{l} \text{--- 5} \\ \text{--- 5} \end{array} \\ &= \frac{\frac{a}{2} \int_0^{\pi/2} 2 \sin \theta \cos \theta d\theta}{\int_0^{\pi/2} \sin \theta d\theta} \end{aligned}$$

$$\begin{aligned}
 &= \frac{\frac{a}{2} \int_0^{\pi/2} \sin 2\theta \, d\theta}{\int_0^{\pi/2} \sin \theta \, d\theta} \\
 &= \frac{\frac{a}{2} \left[ -\frac{\cos 2\theta}{2} \right]_0^{\pi/2}}{\left[ -\cos \theta \right]_0^{\pi/2}} = \frac{a}{4} \frac{(\cos \pi - \cos 0)}{(\cos \pi/2 - \cos 0)} \quad \text{--- (5)} \\
 &= \frac{a}{4} \frac{(-1 - 1)}{(0 - 1)} = \frac{a}{4} \cdot 2 = \frac{a}{2} \quad \text{--- (5)}
 \end{aligned}$$

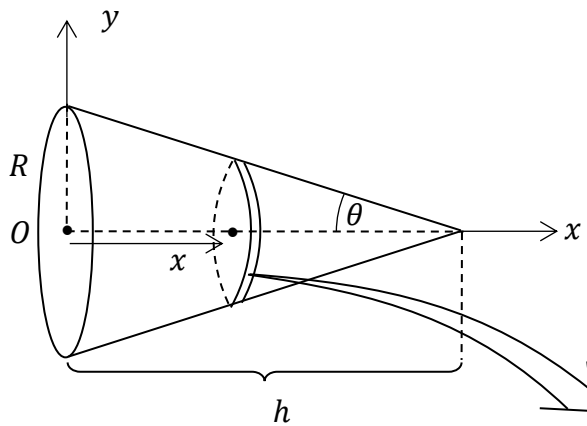

Let the surface density of material of cone,  $\rho \text{ kg m}^{-2}$

Consider the small, hollow cylindrical part whose centre of mass is on  $OX$  at a distance  $x$  from  $O$ .

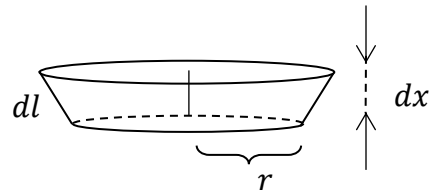

$$\begin{aligned}
 dl \cos \theta &= dx \\
 \therefore dl &= dx \cdot \sec \theta
 \end{aligned}$$

mass of small part

$$\begin{aligned}
 \therefore m_i &= 2\pi r dl \rho \\
 &= 2\pi r \cdot dx \sec \theta \rho
 \end{aligned}$$

radius  $r$  of this is depends on  $x$ .  $\therefore$  It can be obtained in terms of  $x$  variable.

$$\tan \theta = \frac{r}{h-x} \quad \text{or} \quad \tan \theta = \frac{R}{h}$$

$$\therefore \frac{r}{h-x} = \frac{R}{h} \Rightarrow r = \frac{R}{h}(h-x) \quad \text{--- (5)}$$

Now, if the distance to center of mass of entire cone from  $O$ , along  $ox$  is  $\bar{x}$ .

$$\bar{x} = \frac{\int m_i x_i}{\int m_i}, \quad (x_i - \text{distance to centre of mass of small point along } ox)$$

$$\begin{aligned}
 &= \frac{\int_0^h 2\pi r \, dx \sec \theta \rho \cdot x}{\int_0^h 2\pi r \, dx \sec \theta \rho} \quad (\pi, \rho, \theta - \text{are constants}) \\
 &\quad \text{--- (5)} \quad \text{--- (5)}
 \end{aligned}$$

$$\begin{aligned}
&= \frac{\int_0^h \frac{R}{h} (h-x) x \, dx}{\int_0^h \frac{R}{h} (h-x) \, dx} \\
&= \frac{\int_0^h (h-x) x \, dx}{\int_0^h (h-x) \, dx} \\
&= \frac{\int_0^h (hx - x^2) \, dx}{\int_0^h (h-x) \, dx} \\
&= \frac{\left[ h \frac{x^2}{2} - \frac{x^3}{3} \right]_0^h}{\left[ hx - \frac{x^2}{2} \right]_0^h} \quad \text{--- (5)} \\
&= \frac{\left( \frac{h^3}{2} - \frac{h^3}{3} \right)}{\left( h^2 - \frac{h^2}{2} \right)} = \frac{3h^3 - 2h^3}{6h^2 - 3h^2} = \frac{h^3}{3h^2} \quad \text{--- (5)}
\end{aligned}$$

$$\therefore \bar{x} = \frac{1}{3}h //$$

Entire cone is symmetry about  $OX$  axis.  $\therefore$  The centre of mass of entire cone is on  $OX$ .

$$\therefore \bar{y} = 0$$

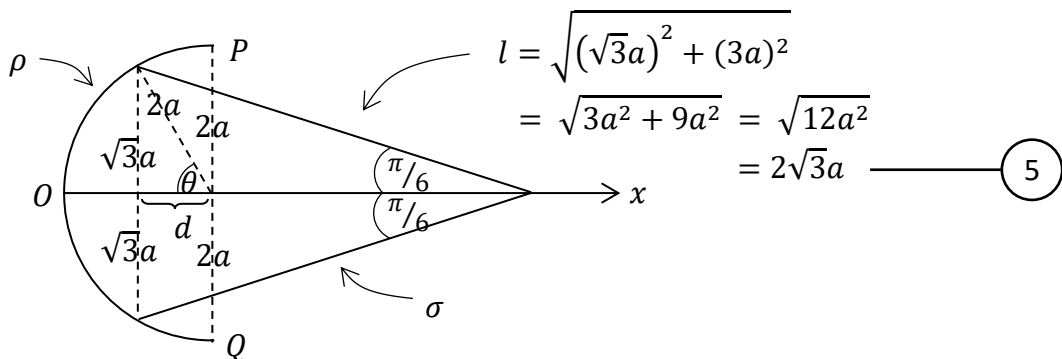

If the perpendicular height of hollow cone is  $h$

$$\tan(\pi/6) = \frac{\sqrt{3}a}{h}$$

$$\frac{1}{\sqrt{3}} = \frac{\sqrt{3}a}{h}$$

$$h = 3a \quad \text{--- (5)}$$

PAPERMASTER.LK

$$\sin \theta = \frac{\sqrt{3}a}{2a}$$

$$\sin \theta = \frac{\sqrt{3}}{2}$$

$$\therefore \theta = \pi/3 \quad \text{--- (5)}$$

$$\therefore d = 2a \cos(\pi/3)$$

$$= a$$

Determination of centre of mass of composite body.

<p>(+)</p>	$m_1 = A\rho$ $= \frac{1}{2}4\pi(2a)^2\rho$ $= 8\pi a^2\rho \quad \text{--- (5)}$	$x_1 = \frac{2a}{2}$ $= a$
<p>(=)</p>	$m_2 = A\sigma = \pi r l \sigma$ $= \pi(\sqrt{3}a)(2\sqrt{3}a)\sigma$ $= 6\pi a^2\sigma \quad \text{--- (5)}$	$x_2 = a + \frac{1}{3}(3a)$ $= 2a$
	$M = (m_1 + m_2)$ $= 8\pi a^2\rho + 6\pi a^2\sigma$ $= 2\pi a^2(4\rho + 3\sigma)$	$\bar{x}$

$$\overset{\curvearrowright}{0} \Rightarrow m_1 g \cdot x_1 + m_2 g \cdot x_2 = M g \cdot \bar{x} \quad \text{--- (5)}$$

$$8\pi a^2 \rho \cdot a + 6\pi a^2 \sigma \cdot 2a = 2\pi a^2 (4\rho + 3\sigma) \bar{x}$$

$$4\rho \cdot a + 3\sigma \cdot 2a = (4\rho + 3\sigma) \bar{x} \quad \text{--- (5)}$$

$$\therefore \bar{x} = \frac{2(2\rho + 3\sigma)}{(4\rho + 3\sigma)}$$

PAPERMASTER.LK

When the composite body hangs freely from  $P$ , the point  $P$  and the centre of mass of entire object  $G$  are on the same vertical line.

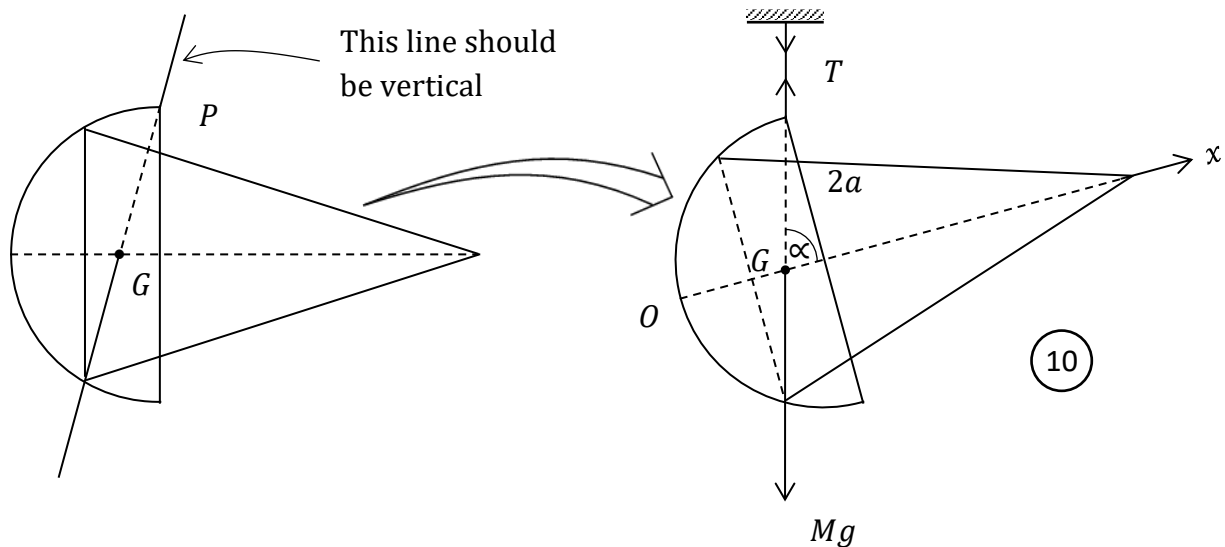

$$\alpha = \tan^{-1}(3)$$

$$\tan \alpha = 3$$

$$\frac{2a}{2a - OG} = 3$$

$$2a = 6a - 3(OG)$$

$$3(OG) = 4a \quad \text{--- (5)}$$

$$\frac{3.2(2\rho + 3\sigma)a}{(4\rho + 3\sigma)} = 4a$$

$$3(2\rho + 3\sigma) = 2(4\rho + 3\sigma)$$

$$6\rho + 9\sigma = 8\rho + 6\sigma$$

$$3\sigma = 2\rho$$

$$\frac{3}{2} = \frac{\rho}{\sigma} \quad \text{--- (10)}$$

$$\Rightarrow \rho : \sigma = 3 : 2 //$$

Now consider the horizontal position of symmetric axis OX by joining the extra particle to the vertex of cone.

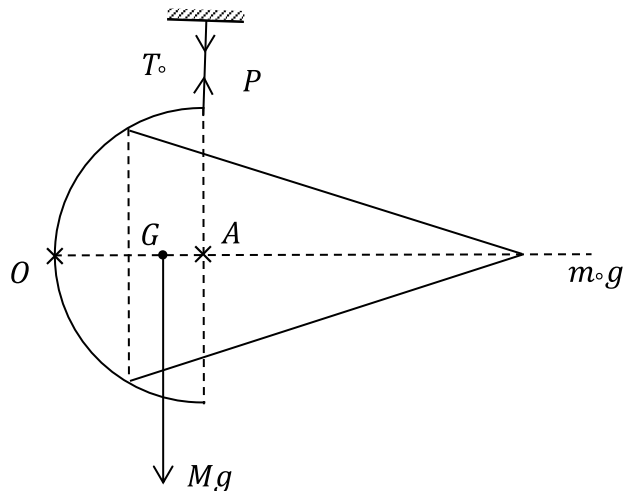

By considering the equilibrium of system.

$$\overset{\curvearrowright}{A} = \overset{\curvearrowleft}{A}$$

$$Mg.(2a - OG) = m_0 g. 2a$$

$$2\pi a^2(4\rho + 3\sigma) \left[ 2a - \frac{2(2\rho + 3\sigma)a}{4\rho + 3\sigma} \right] = m_0. 2a \quad \text{--- (10)}$$

$$\left( \text{as } \frac{\rho}{\sigma} = \frac{3}{2} \Rightarrow \text{applying } \sigma = \frac{2\rho}{3} \right)$$

$$2\pi a^2 \left( 4\rho + 3 \cdot \frac{2\rho}{3} \right) \left[ 1 - \frac{(2\rho + 3 \cdot \frac{2\rho}{3})}{4\rho + 3 \cdot \frac{2\rho}{3}} \right] = m_0 \quad \text{--- (10)}$$

$$2\pi a^2 6\rho \left[ 1 - \frac{4\rho}{6\rho} \right] = m_0$$

$$2\pi a^2 6\rho \left( \frac{2}{6} \right) = m_0$$

$$m_0 = 4\pi a^2 \rho$$

$$\text{Mass of hollow hemisphere} = M_1 = 8\pi a^2 \rho$$

$$\therefore m_0 = \frac{1}{2} M_1 \quad \text{--- (5)}$$

17.

- (a). In a certain population 40% are male. Among this male population  $p\%$  are government servants. The probability of a female in this population being a government servant is  $q$ .

Probability of a person who is selected at random from this population is a male-government servant is 0.08 and a female - government servant is 0.18.

Draw a tree diagram to illustrate above data.

Find the values of  $p$  and  $q$ .

Find the probability of a person, selected at random from this population is,

- (i) Not a government servant.
- (ii) Either a male or a female-government servant,
- (iii) Not a male-government servant
- (iv) If not a government servant, probability of being a female,

Answer -

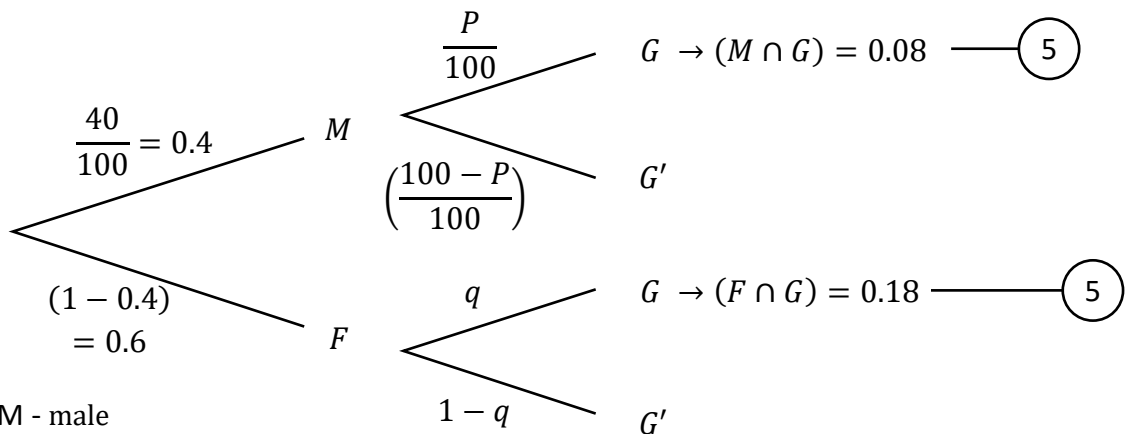

M - male  
F - female  
G - government servant

$$\begin{aligned}
 P(M \cap G) &= 0.08 \\
 0.4 \times \frac{P}{100} &= 0.08 \\
 P &= \frac{8}{0.4} \\
 &= 20 // \quad \text{--- (5)}
 \end{aligned}$$

$$\begin{aligned}
 P(F \cap G) &= 0.18 \\
 0.6 \times q &= 0.18 \\
 q &= \frac{18}{60} \\
 &= 0.3 // \quad \text{--- (5)}
 \end{aligned}$$

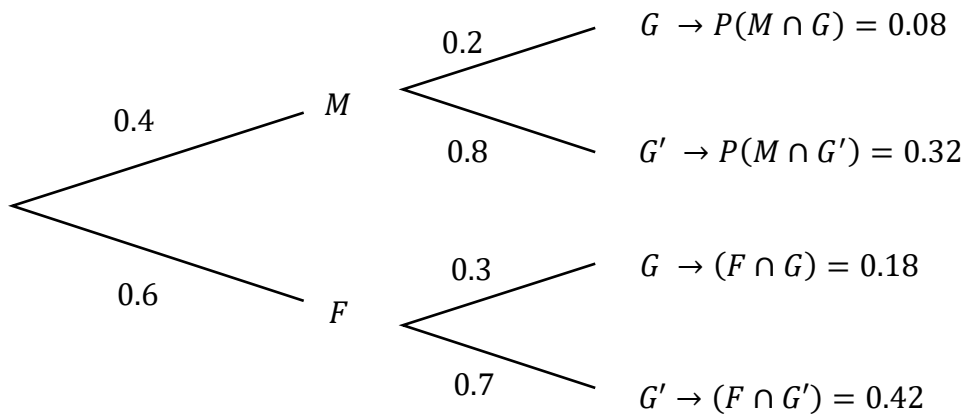

(i).  $P(G') = P(M \cap G') + P(F \cap G')$  ————— (5)  
 $= 0.32 + 0.42$   
 $= 0.74 //$  ————— (5)

(ii).  $P(M \cup (F \cap G)) = P(M) + P(F \cap G)$  ————— (5)  
 $= 0.4 + 0.18$   
 $= 0.58 //$  ————— (5)

(iii).  $P(G \cap M)' = 1 - P(G \cap M)$  ————— (5)  
 $= 1 - 0.08$   
 $= 0.92 //$  ————— (5)

(iv).  $P(F|G') = \frac{P(F \cap G')}{P(G')}$  ————— (5)  
 $= \frac{0.42}{0.74}$   
 $= \frac{42}{74} = \frac{21}{37} //$  ————— (5)

(b). Following table represent a set of no of 120 data which divided in to 6 equal class intervals.

Mid point (class mark) of each class interval and the respective frequencies are given there. **Mode** of this distribution is 52.5

Writedown all the class intervals in integer form.

Find the values of  $f_1$  and  $f_2$ .

What is the **median** of this frequency distributic.

By using the code,  $u_i = \left(\frac{x_i - \bar{x}}{c}\right)$  in usual notation calculate the **mean, variance** and the **coefficient of skewness** of the distribution.

	class interval	mid point (class mark)	frequency	
1		10	12	
2		25	$f_1$	
3		40	$f_2$	
4		55	33	
5		70	13	
6		85	14	

Solution -

As the mode of the distribution is 52.5, it is in the 4<sup>th</sup> class interval.

also Mode,  $M_o = L + \frac{C\Delta_1}{\Delta_1 + \Delta_2}$

$$\therefore 52.5 = 47.5 + \frac{15(33 - f_2)}{(33 - f_2) + 20} \quad \text{————— (10)}$$

$$\frac{15(33 - f_2)}{53 - f_2} = 5$$

$$99 - 3f_2 = 53 - f_2$$

$$99 - 53 = 2f_2$$

$$f_2 = 23 // \quad \text{————— (5)}$$

Total number of datas, is 120

$$\therefore \sum F_i = 120$$

$$12 + F_1 + F_2 + 33 + 13 + 14 = 120 \quad \text{————— (5)}$$

$$\text{by substituting } f_2 = 23 \Rightarrow f_1 = 25 // \quad \text{————— (5)}$$

PAPERMASTER.LK



Mode of the distribution

$$M_d = L + \frac{\left(\frac{N_2}{2} - Cuf_L\right) C}{f_{md}}$$

$$= 32.5 + \frac{(60 - 37) 15}{23} \quad \text{--- (10)}$$

$$= 32.5 + 15 = 47.5 \quad \text{// (5)}$$

Another method

By considering the cumulative frequency, it is 60 at the upper boundary of the class interval 33-47. Also the total number of datas is 120.  $\therefore$  The median is the data at the 60<sup>th</sup> position. So it must be the upper boundary of 33-47 class.

$\therefore$  Median is 47.5 //

class interval	mid point (class mark) $x_i$	$f_i$	$Cuf$	$U_i$	$U_i^2$	$f_i U_i$	$f_i U_i^2$
3 — 17	10	12	12	-3	9	-36	108
18 — 32	25	25	39	-2	4	-50	100
33 — 47	40	23	60	-1	1	-23	23
48 — 62	55	33	93	0	0	0	0
63 — 77	70	13	106	1	1	13	13
78 — 92	85	14	120	2	4	28	56
		120				$\sum f_i U_i = -68$	$\sum f_i U_i^2 = 300$

$$\bar{x} = \mu = A + \frac{C \sum f_i U_i}{\sum f_i}$$

$$= 55 + \frac{15(-68)}{120} \quad \text{--- (5)}$$

$$= 55 - \frac{68}{8}$$

$$= 55 - 8.5$$

$$= 46.5 \quad \text{--- (5)}$$

PAPERMASTER.LK



$$\begin{aligned}
S^2 = \sigma^2 &= C^2 \left[ \frac{\sum f_i U_i^2}{\sum f_i} - \left( \frac{\sum f_i U_i}{\sum f_i} \right)^2 \right] \\
&= 15^2 \left[ \frac{300}{120} - \left( \frac{-68}{120} \right)^2 \right] \quad \text{————— (5)} \\
&= \frac{15^2}{120^2} [300 \times 120 - 68^2] \\
&= \left( \frac{15}{120} \right)^2 [36000 - 4624] \\
&= \left( \frac{1}{8} \right)^2 (31376) \\
&= 490.25 \quad \text{————— (5)}
\end{aligned}$$

$$\begin{aligned}
\therefore \text{Standard deviation, } S = \sigma &= +\sqrt{490.25} \\
&= 22.14 \quad \text{————— (5)}
\end{aligned}$$

Skewness

$$\begin{aligned}
SK &= \left( \frac{\text{mean} - \text{mode}}{\text{standard deviation}} \right) \\
&= \left( \frac{46.5 - 52.5}{22.14} \right) \quad \text{————— (5)} \\
&= -0.27 < 0
\end{aligned}$$

$\therefore$  the distribution is negatively skewed.