

G. C. E (Advanced Level) Examination - 2021(2022)

10 - Combined Mathematics I**Distribution of Marks****Paper I**

$$\text{Part A} \quad = \quad 10 \times 25 \quad = \quad 250$$

$$\text{Part B} \quad = \quad 05 \times 150 \quad = \quad 750$$

$$\text{Total} \quad = \quad \frac{1000}{10}$$

$$\text{Final marks} \quad = \quad 100$$

Common Techniques of Marking Answer Scripts.

It is compulsory to adhere to the following standard method in marking answer scripts and entering marks into the mark sheets.

1. Use a red color ball point pen for marking. (Only Chief/Additional Chief Examiner may use a mauve color pen.)
2. Note down Examiner's Code Number and initials on the front page of each answer script.
3. Write off any numerals written wrong with a clear single line and authenticate the alterations with Examiner's initials.
4. Write down marks of each subsection in a \triangle and write the final marks of each question as a rational number in a \square with the question number. Use the column assigned for Examiners to write down marks.

Example: Question No. 03

(i)	✓	\triangle $\frac{4}{5}$
		
		
(ii)	✓	\triangle $\frac{3}{5}$
		
		
(iii)	✓	\triangle $\frac{3}{5}$
		
		

03	(i)	$\frac{4}{5}$	+	(ii)	$\frac{3}{5}$	+	(iii)	$\frac{3}{5}$	=	\square $\frac{10}{15}$
--	-----	---------------	---	------	---------------	---	-------	---------------	---	------------------------------

MCQ answer scripts: (Template)

1. Marking templates for G.C.E.(A/L) and GIT examination will be provided by the Department of Examinations itself. Marking examiners bear the responsibility of using correctly prepared and certified templates.
2. Then, check the answer scripts carefully. If there are more than one or no answers Marked to a certain question write off the options with a line. Sometimes candidates may have erased an option marked previously and selected another option. In such occasions, if the erasure is not clear write off those options too.
3. Place the template on the answer script correctly. Mark the right answers with a 'v' and the wrong answers with a 'X' against the options column. Write down the number of correct answers inside the cage given under each column. Then, add those numbers and write the number of correct answers in the relevant cage.

Structured essay type and assay type answer scripts:

1. Cross off any pages left blank by candidates. Underline wrong or unsuitable answers. Show areas where marks can be offered with check marks.
2. Use the right margin of the overland paper to write down the marks.
3. Write down the marks given for each question against the question number in the relevant cage on the front page in two digits. Selection of questions should be in accordance with the instructions given in the question paper. Mark all answers and transfer the marks to the front page, and write off answers with lower marks if extra questions have been answered against instructions.
4. Add the total carefully and write in the relevant cage on the front page. Turn pages of answer script and add all the marks given for all answers again. Check whether that total tallies with the total marks written on the front page.

Preparation of Mark Sheets.

Except for the subjects with a single question paper, final marks of two papers will not be calculated within the evaluation board this time. Therefore, add separate mark sheets for each of the question paper. Write paper 01 marks in the paper 01 column of the mark sheet and write them in words too. Write paper II Marks in the paper II Column and write the relevant details.

1. Using the Principle of Mathematical Induction, prove that $\sum_{r=1}^n (6r+1) = n(3n+4)$ for all $n \in \mathbb{Z}^+$.

For $n = 1$, L.H.S. = $6+1=7$ and

$$\text{R.H.S.} = 1(3+4) = 7$$

Hence, the result is true for $n = 1$.

5

For verifying the result for $n=1$

Let k be any positive integer and suppose that the result is true for $n = k$.

i.e $\sum_{r=1}^k (6r+1) = k(3k+4)$.

5

For writing the statement for $n=k$

Now, $\sum_{r=1}^{k+1} (6r+1) = \sum_{r=1}^k (6r+1) + \{6(k+1)+1\}$

$$= k(3k+4) + 6k + 7$$

5

For substituting " $n=k$ result" in " $n=k+1$ "

$$= 3k^2 + 10k + 7$$

$$= (k+1)(3k+7)$$

5

$(k+1)(3k+7)$ or equivalent seen

$$= (k+1)[3(k+1)+4].$$

Hence, if the result is true for $n = k$,

it is also true for $n = k + 1$. We have already

proved that the result is true for $n = 1$.

Hence, by the Principle of Mathematical Induction,

the result is true for all $n \in \mathbb{Z}$

5

conclusion with the "Principle of Mathematical Induction". (Given only if all the other steps are correct.)

2. Sketch the graphs of $y = 2|x+1|$ and $y = 2-|x|$ in the same diagram.
Hence or otherwise, find all real values of x satisfying the inequality $2|x+2|+|x| \leq 4$.

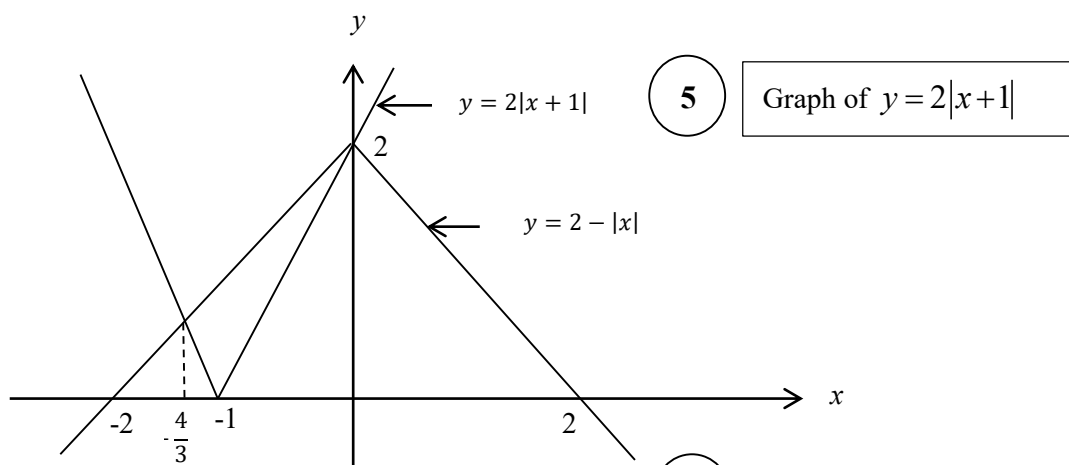

5 Graph of $y = 2|x+1|$

5 Graph of $y = 2-|x|$

(To earn all 10 marks, the common intersection point on the y - axis must be seen; otherwise only 5)

The x - coordinate of one point of intersection is $x = 0$.

The x - coordinate of the other point of intersection is given by $-2(x+1) = 2+x$ for $x < -1$.

This gives $x = -\frac{4}{3}$. 5

$x = 0$ and $x = -\frac{4}{3}$ seen

Let $t = \frac{x}{2}$. 5

$t = \frac{x}{2}$ substitution or equivalent

Then the given inequality becomes

$$2|2t+2|+|2t| \leq 4.$$

It is equivalent to

$$2|t+1| \leq 2-|t|.$$

From the graphs, we have

$$-\frac{4}{3} \leq t \leq 0.$$

$\therefore -\frac{8}{3} \leq x \leq 0$. 5

correct solution seen

Aliter 1:

For the graphs $\textcircled{5} + \textcircled{5}$, as before.

Case (i) $x \leq -2$:

Then, $2|x+2|+|x| \leq 4$ is equivalent to $-2(x+2)-x \leq 4$.

$$\therefore -\frac{8}{3} \leq x.$$

Hence, in this case, solutions are the values of x satisfying $-\frac{8}{3} \leq x \leq -2$.

Case (ii) $-2 < x \leq 0$:

Then, $2|x+2|+|x| \leq 4$ is equivalent to $2(x+2)-x \leq 4$.

$$\therefore x \leq 0.$$

Hence, in this case, the solutions are the values of x satisfying $-2 < x \leq 0$.

Case (iii) $x > 0$:

Then, $2|x+2|+|x| \leq 4$ is equivalent to $2(x+2)+x \leq 4$

$$\therefore x \leq 0$$

Hence, in this case, there are no solutions.

All 3 cases with correct solutions $\textcircled{10}$

only 2 cases with correct solutions $\textcircled{5}$

\therefore The solutions of the given inequality are the values of x satisfying $-\frac{8}{3} \leq x \leq 0$. $\textcircled{5}$

Aliter 2:

For the graphs (5) + (5), as before.

$$2|x+2|+|x| \leq 4 \text{ is equivalent to } 2|x+2| \leq 4-|x|.$$

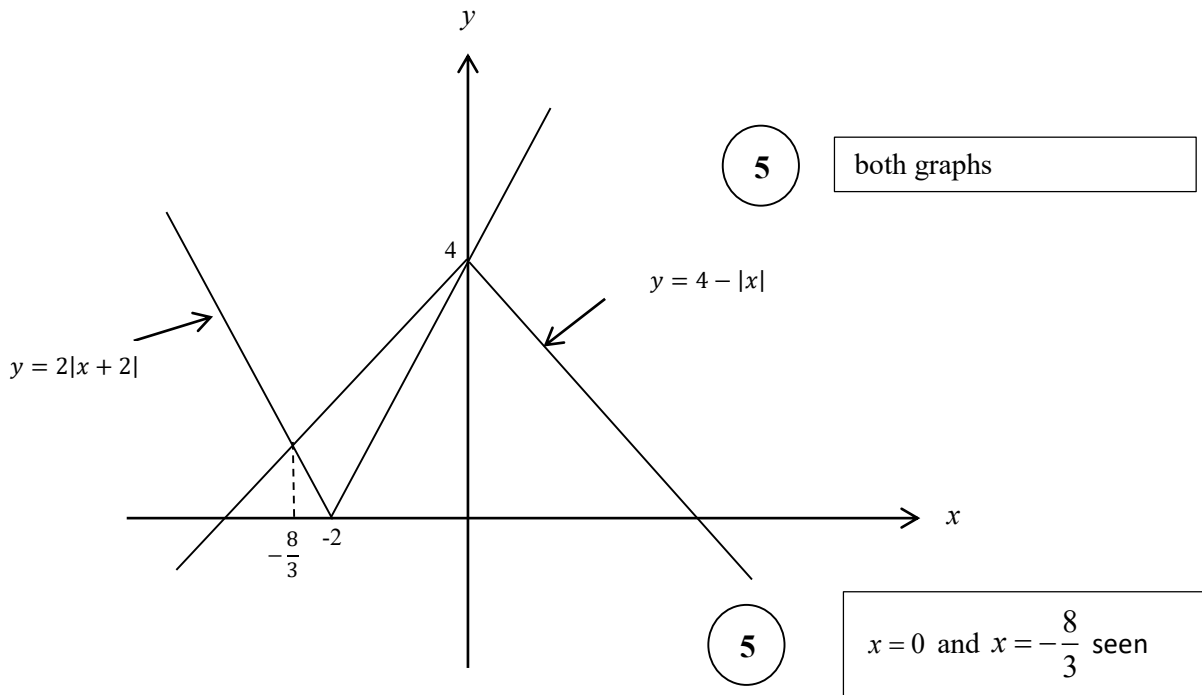

From the graphs,

$$2|x+2| \leq 4-|x|$$

$$\Leftrightarrow -\frac{8}{3} \leq x \leq 0$$

(5)

correct solution seen

3. Sketch, in an Argand diagram, the locus of the points that represent complex numbers z satisfying $\text{Arg}(z - 1 - i) = -\frac{\pi}{4}$.
 Hence or otherwise, show that the minimum value of $|z - 2 + i|$ satisfying $\text{Arg}(iz + 1 - i) = \frac{\pi}{4}$ is $\frac{1}{\sqrt{2}}$.

$$\text{Arg}(z - (1 + i)) = -\frac{\pi}{4}$$

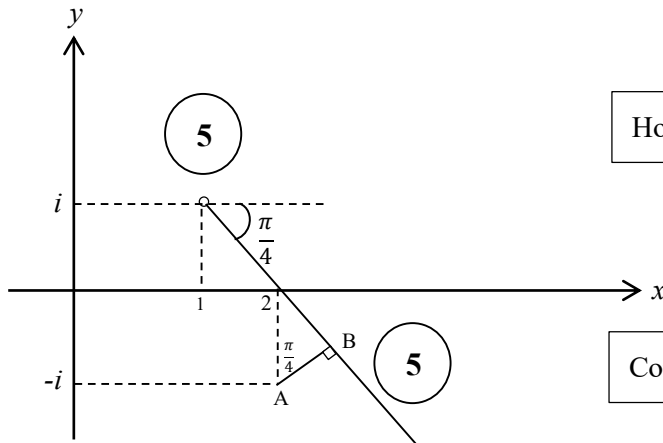

Hole at $1 + i$

Correct half line

$$\text{Arg}(i(z - i - 1)) = \frac{\pi}{4}$$

$$\therefore \text{Arg } i + \text{Arg}(z - (1 + i)) = \frac{\pi}{4}$$

$$\therefore \text{Arg}(z - (1 + i)) = -\frac{\pi}{4} \quad \text{5}$$

Breaking the argument of the product to a sum, and using $\text{Arg } i = \frac{\pi}{2}$.

Now, $\min |z - (2 - i)| = AB \quad \text{5}$

Recognising the minimum distance

$$= 1 \cdot \cos \frac{\pi}{4}$$

$$= \frac{1}{\sqrt{2}} \quad \text{5}$$

Work leading to the answer

Aliter:

For the diagram $\textcircled{5} + \textcircled{5}$ as before.

Let $z = x + iy$

Then $\frac{\pi}{4} = \text{Arg}(iz + 1 - i) = \text{Arg}(1 - y + i(x - 1))$

$$\begin{aligned} \therefore x - 1 &= (1)(1 - y) && \textcircled{5} \\ \Rightarrow x + y &= 2. \end{aligned}$$

Writing the given information as a relation of x and y .

Now $|z - 2 + i| = |x + iy - 2 + i|$

$$= |(x - 2) + i(y + 1)|$$

$$= |y + i(y + 1)| \quad (\because \quad y)$$

$$= \sqrt{y^2 + (y + 1)^2}$$

$$= \sqrt{2\left(y + \frac{1}{2}\right)^2 + \frac{1}{2}} \quad \textcircled{5}$$

Writing the absolute value as a complete square of x or y .

$$\geq \frac{1}{\sqrt{2}}, \text{ since } 2\left(y + \frac{1}{2}\right)^2 \geq 0; \quad (= 0 \text{ when } y = -\frac{1}{2}).$$

$$\therefore \min |z - 2 + i| = \frac{1}{\sqrt{2}} \quad \textcircled{5}$$

Work leading to the answer.

4. Let $k > 0$. It is given that the coefficient of x^7 in the binomial expansion of $\left(x^2 + \frac{k}{x}\right)^{11}$ and the coefficient of x^{-7} in the binomial expansion of $\left(x - \frac{1}{x^2}\right)^{11}$ are equal. Show that $k = 1$.

$k > 0$. For $\left(x^2 + \frac{k}{x}\right)^{11}$;

$$T_{r+1} = {}^{11}C_r (x^2)^{11-r} \left(\frac{k}{x}\right)^r = {}^{11}C_r x^{22-3r} k^r$$

$$22 - 3r = 7 \Rightarrow r = 5$$

5

Correct value of r

\therefore The coefficient of $x^7 = {}^{11}C_5 k^5$

5

Correct coefficient

For $\left(x - \frac{1}{x^2}\right)^{11}$; $T_{r+1} = {}^{11}C_r x^{11-r} (-1)^r \left(\frac{1}{x^2}\right)^r = (-1)^r {}^{11}C_r x^{11-3r}$

$$11 - 3r = -7 \Rightarrow r = 6$$

5

Correct value of r

\therefore The coefficient of $x^{-7} = {}^{11}C_6$

5

Correct coefficient

Then, ${}^{11}C_6 = {}^{11}C_5 k^5$ gives $k = 1$, as ${}^{11}C_6 = {}^{11}C_5$.

5

Work leading to the answer

5. Show that $\lim_{x \rightarrow 0} \frac{\tan 2x - \sin 2x}{x^2(\sqrt{1+x} - \sqrt{1-x})} = 4$.

$$\lim_{x \rightarrow 0} \frac{\tan 2x - \sin 2x}{x^2(\sqrt{1+x} - \sqrt{1-x})}$$

$$= \lim_{x \rightarrow 0} \frac{\frac{\sin 2x}{\cos 2x} - \sin 2x}{x^2(\sqrt{1+x} - \sqrt{1-x})} \times \frac{(\sqrt{1+x} + \sqrt{1-x})}{(\sqrt{1+x} + \sqrt{1-x})} \quad \text{5} \quad \text{Multiplying by the conjugate}$$

$$= \lim_{x \rightarrow 0} \frac{\sin 2x}{2x} \times \frac{(1 - \cos 2x)}{x^2 \cos 2x} \times (\sqrt{1+x} + \sqrt{1-x})$$

$$= \left(\lim_{2x \rightarrow 0} \frac{\sin 2x}{2x} \right) \times \lim_{x \rightarrow 0} 2 \left(\frac{\sin x}{x} \right)^2 \times \left(\lim_{x \rightarrow 0} \frac{1}{\cos 2x} \right) \times \lim_{x \rightarrow 0} (\sqrt{1+x} + \sqrt{1-x})$$

$$= \overset{1}{\text{5}} \times \overset{2}{\text{5}} \times \overset{1}{\text{5}} \times \overset{2}{\text{5}}$$

$$= 4.$$

Each limit 5

Aliter 1:

$$\lim_{x \rightarrow 0} \frac{\tan 2x - \sin 2x}{x^2(\sqrt{1+x} - \sqrt{1-x})}$$

$$= \lim_{x \rightarrow 0} \frac{\sin 2x(1 - \cos 2x)}{x^2 \cos 2x} \cdot \frac{1}{\sqrt{1+x} - \sqrt{1-x}} \times \frac{\sqrt{1+x} + \sqrt{1-x}}{\sqrt{1+x} + \sqrt{1-x}} \quad \text{5} \quad \text{multiplying by the conjugate}$$

$$= \lim_{x \rightarrow 0} \frac{\sin 2x(1 - \cos^2 2x)}{x^2 \cos 2x(1 + \cos 2x)} \cdot \frac{\sqrt{1+x} + \sqrt{1-x}}{2x}$$

$$= 4 \left(\lim_{2x \rightarrow 0} \frac{\sin 2x}{2x} \right)^3 \left(\lim_{x \rightarrow 0} \frac{1}{\cos 2x} \right) \left(\lim_{x \rightarrow 0} \frac{1}{1 + \cos 2x} \right) \left(\lim_{x \rightarrow 0} \sqrt{1+x} + \sqrt{1-x} \right)$$

$$= 4 \times 1 \times 1 \times \frac{1}{2} \times 2$$

$$\text{5} \quad \text{5} \quad \text{5} \quad \text{5}$$

Each limit

5

$$= 4.$$

Aliter 2:

$$\lim_{x \rightarrow 0} \frac{\tan 2x - \sin 2x}{x^2(\sqrt{1+x} - \sqrt{1-x})}$$

5

multiplying by the conjugate

$$= \lim_{x \rightarrow 0} \frac{1}{x^2} \times \left(\frac{2 \tan x}{1 - \tan^2 x} - \frac{2 \tan x}{1 + \tan^2 x} \right) \frac{1}{\sqrt{1+x} - \sqrt{1-x}} \times \frac{(\sqrt{1+x} + \sqrt{1-x})}{(\sqrt{1+x} + \sqrt{1-x})}$$

$$= \lim_{x \rightarrow 0} \frac{2 \tan x (2 \tan^2 x)}{x^2 (1 - \tan^4 x)} \cdot \frac{\sqrt{1+x} + \sqrt{1-x}}{2x}$$

$$= 2 \left(\lim_{x \rightarrow 0} \frac{\sin x}{x} \right)^3 \left(\lim_{x \rightarrow 0} \frac{1}{\cos x} \right)^3 \left(\lim_{x \rightarrow 0} \frac{1}{1 - \tan^4 x} \right) \left(\lim_{x \rightarrow 0} \sqrt{1+x} + \sqrt{1-x} \right)$$

$$= 2 \times 1 \times 1 \times 1 \times 2$$

$$= 4.$$

Each limit

5

6. Let S be the region enclosed by the curves $y = \frac{\ln x}{\sqrt{x}}$, $y = 0$ and $x = e^2$. Show that the area of S is 4 square units.

The region S is rotated about the x -axis through 2π radians. Show that the volume of the solid thus generated is $\frac{8\pi}{3}$.

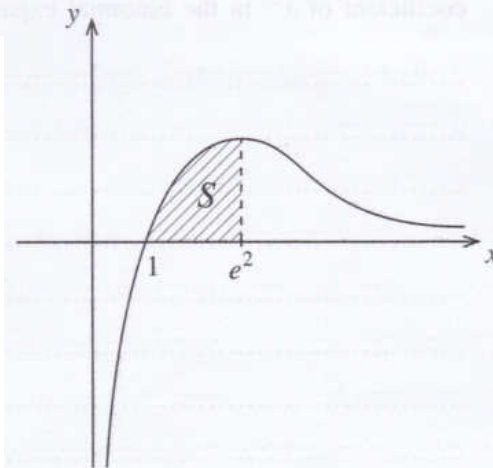

$$\text{Area of } S = \int_1^{e^2} \frac{\ln x}{\sqrt{x}} dx \quad (5)$$

Setting up the integral for S

$$= (\ln x) \cdot 2x^{\frac{1}{2}} \Big|_1^{e^2} - \int_1^{e^2} 2x^{\frac{1}{2}} \times \frac{1}{x} dx \quad (5)$$

Integration by parts or equivalent

$$= 4e - 2 \int_1^{e^2} x^{-\frac{1}{2}} dx$$

$$= 4e - (2\sqrt{x}) \Big|_1^{e^2}$$

$$= 4e - 4e + 4$$

$$= 4 \quad (5)$$

Work leading to the answer

$$\text{The volume required} = \int_1^{e^2} \pi \left(\frac{\ln x}{\sqrt{x}} \right)^2 dx \quad (5)$$

Setting up the integral for the volume

$$= \pi \int_1^{e^2} \frac{(\ln x)^2}{x} dx$$

$$= \pi \frac{(\ln x)^3}{3} \Big|_1^{e^2}$$

$$= \frac{8\pi}{3} \quad (5)$$

Work leading to the answer

PAPERMASTER.LK

7. Show that the equation of the tangent line to the rectangular hyperbola parametrically given by $x = ct$ and $y = \frac{c}{t}$ for $t \neq 0$, at the point $P \equiv \left(cp, \frac{c}{p} \right)$ is given by $x + p^2y = 2cp$.
 The normal line to this hyperbola at P meets the hyperbola again at another point $Q \equiv \left(cq, \frac{c}{q} \right)$.
 Show that $p^3q = -1$.

$$\frac{dx}{dt} = c \quad \text{and} \quad \frac{dy}{dt} = -\frac{c}{t^2} \quad (t \neq 0.)$$

$$\therefore \frac{dy}{dx} = \frac{\frac{dy}{dt}}{\frac{dx}{dt}} = \frac{-\frac{c}{t^2}}{c} = -\frac{1}{t^2}$$

$\frac{dy}{dx}$ in terms of t

$$\therefore \text{The gradient of the tangent at } P = -\frac{1}{t^2} \Big|_{t=p} = -\frac{1}{p^2}$$

\therefore The equation of the tangent at P :

$$y - \frac{c}{p} = -\frac{1}{p^2} (x - cp)$$

$$\therefore x + p^2y = 2cp. \quad (5)$$

Work leading to the answer

The gradient of the normal at $P = p^2$.

$$\therefore \text{Equation of the normal at } P; \quad y - \frac{c}{p} = p^2(x - cp) \quad (5)$$

Equation of the normal

$Q \equiv \left(cq, \frac{c}{q} \right)$ is on this line;

$$\therefore \frac{c}{q} - \frac{c}{p} = p^2(cq - cp) \Rightarrow c(p - q) = -p^3qc(p - q) \quad (5)$$

For the substitution

Since P and Q are distinct points, we have $p \neq q$.

$$p^3q = -1. \quad (5)$$

Work leading to the answer

Aliter: (For the last part)

$$\text{Gradient of } PQ = \text{Gradient of the normal line at } P \quad (5)$$

For the condition

$$\therefore \frac{\frac{c}{q} - \frac{c}{p}}{cq - cp} = p^2 \quad (5)$$

($\because \neq 0$)

For the substitutions

$$\therefore p^3q = -1 \quad (5)$$

Work leading to the answer

PAPERMASTER.LK

8. Let $A \equiv (0, -1)$ and $B \equiv (9, 8)$. The point C lies on AB such that $AC : CB = 1 : 2$. Show that the equation of the straight line l through C perpendicular to AB is $x + y - 5 = 0$.
 Let D be the point on l such that AD is parallel to the straight line $y = 5x + 1$. Find the coordinates of D .

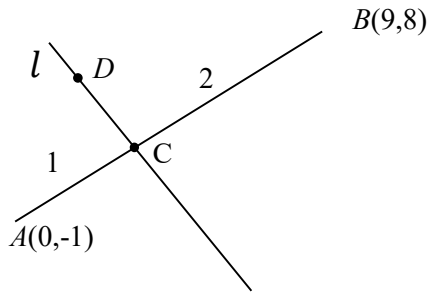

$$C \equiv \left(\frac{2(0)+1(9)}{2+1}, \frac{2(-1)+1(8)}{2+1} \right)$$

$$\equiv (3, 2) \quad \text{5}$$

Coordinates of C

The gradient of $AB = 1$.

The gradient of $l = -1$ 5

For the gradient of l

\therefore Equation of l :

$$y - 2 = -1(x - 3)$$

i.e. $x + y - 5 = 0$. ----- (1) 5

Work leading to the equation of l

Equation of AD ; $y - (-1) = 5(x - 0)$ 5

Work leading to the coordinates of D

i.e. $y + 1 = 5x$ ----- (2)

Solving (1) and (2)

$\therefore D \equiv (1, 4)$. 5

$D \equiv (1, 4)$ seen

9. Show that the straight line $x + 2y = 3$ intersects the circle $S \equiv x^2 + y^2 - 4x + 1 = 0$ at two distinct points.
Find the equation of the circle passing through these two points and the centre of the circle $S = 0$.

$$S \equiv x^2 + y^2 - 4x + 1 = 0$$

$$\text{Let } \ell \quad x + 2y - 3 = 0.$$

$$\text{On } \ell \quad x = 3 - 2y;$$

$$(3 - 2y)^2 + y^2 - 4(3 - 2y) + 1 = 0$$

$$\therefore 5y^2 - 4y - 2 = 0 \quad (5)$$

$$\text{Discriminant of this quadratic } \Delta = 16 + 4(5)(2) \quad (5)$$

\therefore Since $\Delta > 0$, the line $x + 2y = 3$ intersects S at two distinct points.

The equation of the required circle can be written as

$$x^2 + y^2 - 4x + 1 + \lambda(x + 2y - 3) = 0, \quad (5)$$

where $\lambda \in \mathbb{R}$

This circle passes through $(2, 0)$, we have

$$4 - 8 + 1 + \lambda(2 - 3) = 0$$

$$\therefore \lambda = -3 \quad (5)$$

\therefore Equation of the required circle is

$$x^2 + y^2 - 4x + 1 + (-3)(x + 2y - 3) = 0$$

$$\text{i.e. } x^2 + y^2 - 7x - 6y + 10 = 0.$$

Aliter:

(5)

(5)

Perpendicular distance from the centre $<$ radius

Comparison

(5)

Forming a quadratic

Writing the discriminant

For $\Delta > 0$

For the λ form

$\lambda = -3$ seen

10. Express $2\cos^2 x + 2\sqrt{3}\sin x \cos x - 1$ in the form $R\cos(2x - \alpha)$, where $R > 0$ and $0 < \alpha < \frac{\pi}{2}$.
Hence, solve the equation $\cos^2 x + \sqrt{3}\sin x \cos x = 1$.

$$2\cos^2 x + 2\sqrt{3}\sin x \cos x - 1$$

$$= 2\cos^2 x - 1 + \sqrt{3}(2\sin x \cos x)$$

$$= \cos 2x + \sqrt{3}\sin 2x$$

5

Writing the expression using
 $\cos 2x$ and $\sin 2x$

$$= 2 \left[\frac{1}{2}\cos 2x + \frac{\sqrt{3}}{2}\sin 2x \right]$$

$$= 2\cos\left(2x - \frac{\pi}{3}\right)$$

Here $R = 2$ and $\alpha = \frac{\pi}{3}$

5

5

 $R = 2$ seen $\alpha = \frac{\pi}{3}$ seen

The equation $\cos^2 x + \sqrt{3}\sin x \cos x = 1$ is equivalent to

$$2\cos^2 x + 2\sqrt{3}\sin x \cos x - 1 = 1.$$

$$\therefore 2\cos\left(2x - \frac{\pi}{3}\right) = 1$$

Hence $\cos\left(2x - \frac{\pi}{3}\right) = \frac{1}{2}$

5

 $\cos\left(2x - \frac{\pi}{3}\right) = \frac{1}{2}$ seen

$$\therefore 2x - \frac{\pi}{3} = 2n\pi \pm \frac{\pi}{3}; n \in \mathbb{Z}$$

$$\therefore x = n\pi + \frac{\pi}{6} \pm \frac{\pi}{6}; n \in \mathbb{Z}$$

5

Correct solution seen

11. (a) Let $k > 1$. Show that the equation $x^2 - 2(k+1)x + (k-3)^2 = 0$ has real distinct roots.
 Let α and β be these roots. Write down $\alpha + \beta$ and $\alpha\beta$ in terms of k , and find the values of k such that both α and β are positive.
 Now, let $1 < k < 3$. Find the quadratic equation whose roots are $\frac{1}{\sqrt{\alpha}}$ and $\frac{1}{\sqrt{\beta}}$, in terms of k .

(b) Let $f(x) = 2x^3 + ax^2 + bx + 1$ and $g(x) = x^3 + cx^2 + ax + 1$, where $a, b, c \in \mathbb{R}$. It is given that the remainder when $f(x)$ is divided by $(x-1)$ is 5, and that the remainder when $g(x)$ is divided by $x^2 + x - 2$ is $x + 1$. Find the values of a, b and c .
 Also, with these values for a, b and c , show that $f(x) - 2g(x) \leq \frac{13}{12}$ for all $x \in \mathbb{R}$.

(a)

Let Δ be the discriminant of $x^2 - 2(k+1)x + (k-3)^2 = 0$.

$$\begin{aligned} \text{Then } \Delta &= 4(k+1)^2 - 4(k-3)^2 && \text{(5)} \\ &= 4(k+1+k-3)(k+1-k+3) \\ &= 32(k-1). && \text{(5)} \end{aligned}$$

Since $k > 1$, we have $\Delta > 0$. (5)

\therefore The given equation has real distinct roots. (5)

20

$$\alpha + \beta = 2(k+1) \text{ and } \alpha\beta = (k-3)^2 \quad \text{(5)} + \text{(5)}$$

For α and β both to be positive,
 we must have $\alpha + \beta > 0$ and $\alpha\beta > 0$. (10)

Since $k > 1$, we have $\alpha + \beta = 2(k+1) > 0$ (5)

and $\alpha\beta = (k-3)^2 > 0$ if and only if $k \neq 3$. (10)

\therefore The required values of k are $1 < k < 3$ or $k > 3$.

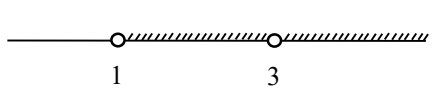

35

Now let $1 < k < 3$. Note that $\alpha > 0$ and $\beta > 0$.

The equation whose roots are $\frac{1}{\sqrt{\alpha}}$ and $\frac{1}{\sqrt{\beta}}$ is $\left(x - \frac{1}{\sqrt{\alpha}}\right)\left(x - \frac{1}{\sqrt{\beta}}\right) = 0$. (5)

i.e. $x^2 - \left(\frac{1}{\sqrt{\alpha}} + \frac{1}{\sqrt{\beta}}\right)x + \frac{1}{\sqrt{\alpha\beta}} = 0$. (5)

i.e. $\sqrt{\alpha\beta}x^2 - (\sqrt{\alpha} + \sqrt{\beta})x + 1 = 0$. (5)

Note that $\sqrt{\alpha\beta} = \sqrt{(k-3)^2} = |k-3| = 3-k$ (\because) (5)

Also, $(\sqrt{\alpha} + \sqrt{\beta})^2 = \alpha + \beta + 2\sqrt{\alpha\beta}$ (5)
 $= 2(k+1) + 2(3-k)$ (5)
 $= 8$. (5)

$\therefore \sqrt{\alpha} + \sqrt{\beta} = 2\sqrt{2}$ (5) (\because $\beta > 0$.)

\therefore The required equation is $(3-k)x^2 - 2\sqrt{2}x + 1 = 0$ (5)

45

(b)

$f(x) = 2x^3 + ax^2 + bx + 1$ and

$g(x) = x^3 + cx^2 + ax + 1$

Since the remainder when $f(x)$ is divided by $(x-1)$ is 5, by the Remainder

Theorem, $f(1) = 5$. (5)

$\therefore a + b + 3 = 5$

$a + b = 2$. (5) ----- (1)

Since, the remainder when $g(x)$ is divided by $x^2 + x - 2$ is $x + 1$, we have

$g(x) = x^3 + cx^2 + ax + 1 = (x^2 + x - 2)(x + \lambda) + x + 1$ for $\lambda \in \mathbb{R}$ (5)

$((x^0)); 1 = -2\lambda + 1$ gives $\lambda = 0$.

$\therefore g(x) = x(x^2 + x - 2) + x + 1$ (5) (5)
 $= x^3 + x^2 - x + 1$. Hence $c = 1$ and $a = -1$.

Now by (1); $b = 3$. (5)

30

$$f(x) - 2g(x) = 2x^3 - x^2 + 3x + 1 - 2(x^3 + x^2 - x + 1)$$

$$= -3x^2 + 5x - 1 \quad (5)$$

$$= -3 \left[\left(x - \frac{5}{6} \right)^2 - \frac{25}{36} + \frac{1}{3} \right]$$

$$= -3 \left[\left(x - \frac{5}{6} \right)^2 - \frac{13}{36} \right] \quad (5)$$

$$\leq -3 \times \left(\frac{-13}{36} \right), \text{ since } \left(x - \frac{5}{6} \right)^2 \geq 0. \quad (5)$$

$$\therefore f(x) - 2g(x) \leq \frac{13}{12}. \quad (5)$$

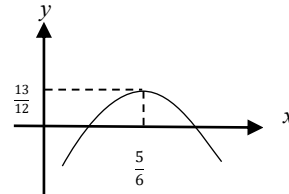

20

12.(a) It is required to form a 4-digit number consisting of 4 digits taken from the 10 digits given below:

1, 1, 1, 2, 2, 3, 3, 4, 5, 5

Find the number of different such 4-digit numbers that can be formed

- (i) if all 4 digits chosen are different,
 (ii) if any 4 digits can be chosen.

(b) Let $U_r = \frac{-16r^3 + 12r^2 + 40r + 9}{5(2r+1)^2(2r-1)^2}$ for $r \in \mathbb{Z}^+$.

Determine the values of the real constants A and B such that $U_r = \frac{A(r-1)}{(2r+1)^2} - \frac{(r-B)}{(2r-1)^2}$ for $r \in \mathbb{Z}^+$.

Hence, find $f(r)$ such that $\frac{1}{5^{r-1}}U_r = f(r) - f(r-1)$ for $r \in \mathbb{Z}^+$, and

show that $\sum_{r=1}^n \frac{1}{5^{r-1}}U_r = 1 + \frac{n-1}{5^n(2n+1)^2}$ for $n \in \mathbb{Z}^+$.

Deduce that the infinite series $\sum_{r=1}^{\infty} \frac{1}{5^{r-1}}U_r$ is convergent and find its sum.

(a)

1, 1, 1, 2, 2, 3, 3, 4, 5, 5

(i) Four different digits out of 1,2,3,4 and 5

$$= {}^5P_4 \quad \textcircled{5}$$

$$= 5! \quad \textcircled{5}$$

$$= 120 \quad \textcircled{5}$$

15

(ii) four digit numbers can be formed by

	number of different such 4 digit numbers
four different digits	${}^5P_4 = 120$
only one digit is repeated twice and the other two are different	${}^4C_1 \times {}^4C_2 \times \frac{4!}{2!} = 288$ <div style="display: flex; justify-content: space-around; align-items: center;"> 10 5 </div>
Two digits repeated twice	${}^4C_2 \times \frac{4!}{2!2!} = 36$ <div style="display: flex; justify-content: space-around; align-items: center;"> 10 5 </div>
one digits repeated thrice	${}^1C_1 \times {}^4C_1 \times \frac{4!}{3!} = 16$ <div style="display: flex; justify-content: space-around; align-items: center;"> 10 5 </div>

The required number of ways = $120 + 288 + 36 + 16$ 5
 = 460 5

55

(b)

For $r \in \mathbb{Z}$

$$U_r = \frac{-16r^3 + 12r^2 + 40r + 9}{5(2r+1)^2(2r-1)^2}$$

$$U_r = \frac{A(r-1)}{(2r+1)^2} - \frac{(r-B)}{(2r-1)^2} = \frac{A(r-1)(2r-1)^2 - (r-B)(2r+1)^2}{(2r+1)^2(2r-1)^2}$$

$$\therefore -16r^3 + 12r^2 + 40r + 9 = 5A(r-1)(4r^2 - 4r + 1) - 5(r-B)(4r^2 + 4r + 1)$$

Comparing coefficients of powers of r :

$$r^3 : -16 = 5A(4) - 20$$

$$r^2 : 12 = 5A(-8) - 5(-4B + 4)$$

$$r^1 : 40 = 25A - 5(1 - 4B)$$

$$r^0 : 9 = -5A + 5B$$

10

PAPERMASTER.LK

These give us $A = \frac{1}{5}$ and $B = 2$.

$$\textcircled{5} \quad \textcircled{5}$$

20

$$\therefore U_r = \frac{r-1}{5(2r+1)^2} - \frac{r-2}{(2r-1)^2} \quad \textcircled{5}$$

$$\therefore \frac{1}{5^{r-1}} U_r = \frac{r-1}{5^r(2r+1)^2} - \frac{r-2}{5^{r-1}(2r-1)^2} \quad \textcircled{5}$$

and hence,

$$\frac{1}{5^{r-1}} U_r = f(r) - f(r-1), \text{ where } f(r) = \frac{r-1}{5^r(2r+1)^2}. \quad \textcircled{10}$$

$$\begin{array}{l} r=1; \\ r=2; \\ \vdots \\ \vdots \end{array} \left. \begin{array}{l} \frac{1}{5^0} U_1 = f(1) - f(0) \\ \frac{1}{5} U_2 = f(2) - f(1) \\ \vdots \\ \vdots \end{array} \right\} \quad \textcircled{5}$$

$$\begin{array}{l} r=n-1; \\ r=n \end{array} \left. \begin{array}{l} \frac{1}{5^{n-2}} U_{n-1} = f(n-1) - f(n-2) \\ \frac{1}{5^{n-1}} U_n = f(n) - f(n-1) \end{array} \right\} \quad \textcircled{5}$$

$$\sum_{r=1}^n \frac{1}{5^{r-1}} U_r = f(n) - f(0) \quad \textcircled{5}$$

$$= \frac{n-1}{5^n(2n+1)^2} - (-1) \quad \textcircled{5}$$

$$= 1 + \frac{n-1}{5^n(2n+1)^2} \text{ for } n \in \mathbb{Z} \quad \textcircled{5}$$

45

$$\lim_{n \rightarrow \infty} \sum_{r=1}^n \frac{1}{5^{r-1}} U_r = \lim_{n \rightarrow \infty} \left(1 + \frac{n-1}{5^n (2n+1)^2} \right)$$

$$\textcircled{5} = 1. \textcircled{5}$$

\therefore the infinite series $\sum_{r=1}^{\infty} \frac{1}{5^{r-1}} U_r$ is convergent and the sum is 1. $\textcircled{5}$

15

13.(a) Let $A = \begin{pmatrix} a & 0 & 3 \\ 0 & a & 1 \end{pmatrix}$ and $B = \begin{pmatrix} a & 1 & 1 \\ 1 & 0 & 1 \end{pmatrix}$, where $a \in \mathbb{R}$.

Also, let $C = AB^T$. Find C in terms of a , and show that C^{-1} exists for all $a \neq 0$.

Write down C^{-1} in terms of a , when it exists.

Show that if $C^{-1} \begin{pmatrix} 1 \\ 2 \end{pmatrix} = \frac{1}{8} \begin{pmatrix} 9 \\ -11 \end{pmatrix}$, then $a = 2$.

With this value for a , find the matrix D such that $DC - C^T C = 8I$, where I is the identity matrix of order 2.

(b) Let $z_1 = 1 + \sqrt{3}i$ and $z_2 = 1 + i$. Express $\frac{z_1}{z_2}$ in the form $x + iy$, where $x, y \in \mathbb{R}$.

Also, express each of the complex numbers z_1 and z_2 in the form $r(\cos \theta + i \sin \theta)$, where $r > 0$ and $0 < \theta < \frac{\pi}{2}$, and hence, show that $\frac{z_1}{z_2} = \sqrt{2} \left(\cos \frac{\pi}{12} + i \sin \frac{\pi}{12} \right)$.

Deduce that $\cos\left(\frac{\pi}{12}\right) = \frac{1 + \sqrt{3}}{2\sqrt{2}}$.

(c) Let $n \in \mathbb{Z}^+$ and $\theta \neq 2k\pi \pm \frac{\pi}{2}$ for $k \in \mathbb{Z}$.

Using De Moivre's theorem, show that $(1 + i \tan \theta)^n = \sec^n \theta (\cos n\theta + i \sin n\theta)$.

Hence, obtain a similar expression for $(1 - i \tan \theta)^n$, and

show that $(1 + i \tan \theta)^n + (1 - i \tan \theta)^n = 2 \sec^n \theta \cos n\theta$.

Deduce that $z = i \tan\left(\frac{\pi}{10}\right)$ is a solution of $(1 + z)^{25} + (1 - z)^{25} = 0$.

(a) $\textcircled{5}$

$$C = AB^T = \begin{pmatrix} a & 0 & 3 \\ 0 & a & 1 \end{pmatrix} \begin{pmatrix} a & 1 \\ 1 & 0 \\ 1 & 1 \end{pmatrix} = \begin{pmatrix} a^2 + 3 & a + 3 \\ a + 1 & 1 \end{pmatrix} \textcircled{10}$$

$|C| = (a^2 + 3) - (a + 1)(a + 3) = -4a$

$\neq 0 (\because \textcircled{5})$

$\therefore C^{-1}$ exists for all $a \neq 0$. $\textcircled{5}$ **25**

For $a \neq 0, C^{-1} = -\frac{1}{4a} \begin{pmatrix} 1 & -(a + 3) \\ -(a + 1) & a^2 + 3 \end{pmatrix} \textcircled{10}$

10

$$C^{-1} \begin{pmatrix} 1 \\ 2 \end{pmatrix} = \frac{1}{4a} \begin{pmatrix} -1 & a+3 \\ a+1 & -a^2-3 \end{pmatrix} \begin{pmatrix} 1 \\ 2 \end{pmatrix} = \frac{1}{4a} \begin{pmatrix} 2a+5 \\ -2a^2+a-5 \end{pmatrix} \quad (10)$$

All 2 entries correct (10)
only 1 correct (5)

$$\therefore \frac{1}{4a} \begin{pmatrix} 2a+5 \\ -2a^2+a-5 \end{pmatrix} = \frac{1}{8} \begin{pmatrix} 9 \\ -11 \end{pmatrix}$$

$$\frac{2a+5}{4a} = \frac{9}{8} \quad \text{and} \quad \frac{-2a^2+a-5}{4a} = -\frac{11}{8} \quad (5)$$

These two equations give us $a = 2$. (5)

20

When $a = 2$, $C = \begin{pmatrix} 7 & 5 \\ 3 & 1 \end{pmatrix}$ and $C^{-1} = -\frac{1}{8} \begin{pmatrix} 1 & -5 \\ -3 & 7 \end{pmatrix}$. (5)

$DC - C^T C = 8I$ is equivalent to $D - C^T = 8IC^{-1}$. (5)

$$\therefore D = C^T + 8C^{-1} = \begin{pmatrix} 7 & 3 \\ 5 & 1 \end{pmatrix} + 8 \left(-\frac{1}{8}\right) \begin{pmatrix} 1 & -5 \\ -3 & 7 \end{pmatrix} = \begin{pmatrix} 6 & 8 \\ 8 & -6 \end{pmatrix}. \quad (5)$$

20

(b)

$$\frac{z_1}{z_2} = \frac{1+\sqrt{3}i}{1+i} \times \frac{1-i}{1-i} = \frac{1}{2}(1+\sqrt{3}i)(1-i) = \underbrace{\frac{1+\sqrt{3}}{2}}_x + i \underbrace{\left(\frac{\sqrt{3}-1}{2}\right)}_y \quad (5)$$

10

$$z_1 = 2 \left(\frac{1}{2} + \frac{\sqrt{3}}{2}i \right) = 2 \left(\cos \frac{\pi}{3} + i \sin \frac{\pi}{3} \right) \quad (5)$$

5

$$z_2 = \sqrt{2} \left(\frac{1}{\sqrt{2}} + \frac{1}{\sqrt{2}}i \right) = \sqrt{2} \left(\cos \frac{\pi}{4} + i \sin \frac{\pi}{4} \right) \quad (5)$$

5

$$\therefore \frac{z_1}{z_2} = \frac{2 \left(\cos \frac{\pi}{3} + i \sin \frac{\pi}{3} \right)}{\sqrt{2} \left(\cos \frac{\pi}{4} + i \sin \frac{\pi}{4} \right)} = \sqrt{2} \left(\cos \left(\frac{\pi}{3} - \frac{\pi}{4} \right) + i \sin \left(\frac{\pi}{3} - \frac{\pi}{4} \right) \right)$$

$$= \sqrt{2} \left(\cos \frac{\pi}{12} + i \sin \frac{\pi}{12} \right) \quad (10)$$

30

Equating real parts,

$$\sqrt{2} \cos \frac{\pi}{12} = \frac{1 + \sqrt{3}}{2}$$

$$\therefore \cos \frac{\pi}{12} = \frac{1 + \sqrt{3}}{2\sqrt{2}} \quad (5)$$

05

(c)

For $n \in \mathbb{Z}$ and $\theta \neq 2k\pi \pm \frac{\pi}{2}$ for $k \in \mathbb{Z}$,

$$(1 + i \tan \theta)^n = \frac{1}{\cos^n \theta} (\cos \theta + i \sin \theta)^n \quad (5)$$

$$= \sec^n \theta (\cos n\theta + i \sin n\theta) \dots\dots\dots (1) \quad (5)$$

10

$$(1 - i \tan \theta)^n = (1 + i \tan(-\theta))^n$$

$$= \sec^n(-\theta) [\cos n(-\theta) + i \sin n(-\theta)]$$

$$= \sec^n \theta (\cos n\theta - i \sin n\theta) \dots\dots\dots (2) \quad (5)$$

(1) and (2) give us $(1 + i \tan \theta)^n + (1 - i \tan \theta)^n = 2 \sec^n \theta \cos n\theta$. (5)

10

$z = i \tan\left(\frac{\pi}{10}\right)$ gives

$$(1 + z)^{25} + (1 - z)^{25} = \left(1 + i \tan\left(\frac{\pi}{10}\right)\right)^{25} + \left(1 - i \tan\left(\frac{\pi}{10}\right)\right)^{25}$$

$$= 2 \sec^{25}\left(\frac{\pi}{10}\right) \cos 25\left(\frac{\pi}{10}\right) \quad (5)$$

$$= 0, \text{ as } \cos 25\left(\frac{\pi}{10}\right) = \cos \frac{\pi}{2} = 0. \quad (5)$$

10

14.(a) Let $f(x) = \frac{4x+1}{x(x-2)}$ for $x \neq 0, 2$.

Show that $f'(x)$, the derivative of $f(x)$, is given by $f'(x) = -\frac{2(2x-1)(x+1)}{x^2(x-2)^2}$ for $x \neq 0, 2$.

Hence, find the intervals on which $f(x)$ is increasing and the intervals on which $f(x)$ is decreasing.

Sketch the graph of $y = f(x)$ indicating the asymptotes, x -intercept and the turning points.

Using this graph, find all real values of x satisfying the inequality $f(x) + |f(x)| > 0$.

(b) The shaded region S of the adjoining figure shows a garden consisting of a rectangle and two sectors of a circle each subtending an angle $\frac{3\pi}{8}$ at the centre. Its dimensions, in metres, are shown in the figure. The area of S is given to be 36 m^2 . Show that the perimeter p m of S is given by $p = 2x + \frac{72}{x}$ for $x > 0$ and that p is minimum when $x = 6$.

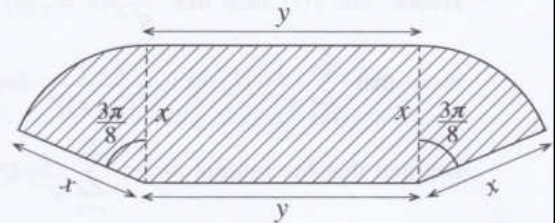

(a)

For $x \neq 0, 2$, $f(x) = \frac{4x+1}{x(x-2)}$

Then, $f'(x) = \frac{4x(x-2) - (4x+1)(x-2+x)}{x^2(x-2)^2}$ 20

$$= -\frac{2(2x^2 + x - 1)}{x^2(x-2)^2}$$

$$= -\frac{2(2x-1)(x+1)}{x^2(x-2)^2} \text{ for } x \neq 0, 2.$$

5

25

Turning points:

$$f'(x) = 0 \iff x = -1 \text{ or } x = \frac{1}{2}$$

5

	$-\infty < x < -1$	$-1 < x < 0$	$0 < x < \frac{1}{2}$	$\frac{1}{2} < x < 2$	$2 < x < \infty$
sign of $f'(x)$	(-)	(+)	(+)	(-)	(-)
$f(x)$ is	↘ decreasing	↗ increasing	↗ increasing	↘ decreasing	↘ decreasing

5

5

5

5

5

$\therefore f(x)$ is increasing on $[-1, 0)$ and $(0, \frac{1}{2}]$

and decreasing on $(-\infty, -1]$, $[\frac{1}{2}, 2)$ and $(2, \infty)$.

30

Turning points: $(\frac{1}{2}, -4)$ is a local maximum.

5

$(-1, -1)$ is a local minimum.

5

x - intercept: $(-\frac{1}{4}, 0)$

5

Horizontal asymptote: $\lim_{x \rightarrow \pm\infty} f(x) = 0 \therefore y = 0$

5

Vertical asymptotes: $x = 0$ and $x = 2$.

5

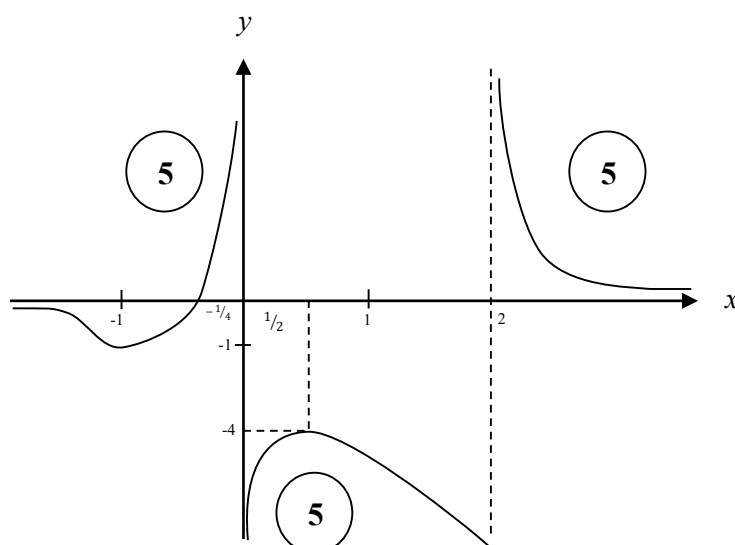

40

Note that $f(x) + |f(x)| = \begin{cases} 2f(x) & \text{if } f(x) \geq 0 \\ 0 & \text{if } f(x) < 0 \end{cases}$

$\therefore f(x) + |f(x)| > 0$ if and only if $f(x) > 0$.

\therefore The real values of satisfying $f(x) + |f(x)| > 0$ is given by

$$\Leftrightarrow -\frac{1}{4} < x < 0 \text{ or } x > 2.$$

5

10

15

(b)

For $x > 0$;

$$\text{Given: } 36 = xy + \frac{3}{8}\pi x^2 \quad (10)$$

$$\therefore y = \frac{36}{x} - \frac{3}{8}\pi x \quad \text{for } x > 0$$

$$p = 2x + 2y + 2\left(\frac{3}{8}\pi x\right) \quad (10)$$

$$= 2x + 2\left(\frac{36}{x} - \frac{3}{8}\pi x\right) + \frac{3}{4}\pi x$$

$$\therefore p = 2x + \frac{72}{x} \quad (5)$$

$$\frac{dp}{dx} = 2 - \frac{72}{x^2}; \quad x > 0.$$

$$(5)$$

$$\frac{dp}{dx} = 0 \quad \Leftrightarrow \quad x = 6. \quad (5)$$

For $0 < x < 6$, $\frac{dp}{dx} < 0$ and

for $x > 6$, $\frac{dp}{dx} > 0$.

$\therefore p$ is minimum when $x = 6$. (5)

40

15.(a) Find the values of the constants A , B and C such that

$$x^4 + 3x^3 + 4x^2 + 3x + 1 = A(x^2 + 1)^2 + Bx(x^2 + 1) + Cx^2 \text{ for all } x \in \mathbb{R}.$$

Hence, write down $\frac{x^4 + 3x^3 + 4x^2 + 3x + 1}{x(x^2 + 1)^2}$ in partial fractions and

find $\int \frac{x^4 + 3x^3 + 4x^2 + 3x + 1}{x(x^2 + 1)^2} dx$.

(b) Let $I = \int_0^{\frac{1}{4}} \sin^{-1}(\sqrt{x}) dx$. Show that $I = \frac{\pi}{24} - \frac{1}{2} \int_0^{\frac{1}{4}} \sqrt{\frac{x}{1-x}} dx$ and hence, evaluate I .

(c) Show that $\frac{d}{dx}(x \ln(x^2 + 1) + 2 \tan^{-1} x - 2x) = \ln(x^2 + 1)$.

Hence, find $\int \ln(x^2 + 1) dx$ and show that $\int_0^1 \ln(x^2 + 1) dx = \frac{1}{2}(\ln 4 + \pi - 4)$.

Using the result $\int_0^a f(x) dx = \int_0^a f(a-x) dx$, where a is a constant,

find the value of $\int_0^1 \ln[(x^2 + 1)(x^2 - 2x + 2)] dx$.

(a)

$$\begin{aligned} x^4 + 3x^3 + 4x^2 + 3x + 1 &= A(x^2 + 1)^2 + Bx(x^2 + 1) + Cx^2 \\ &= A(x^4 + 2x^2 + 1) + B(x^3 + x) + Cx^2 \end{aligned}$$

Comparing coefficients of powers of x ;

$$x^0 : 1 = A$$

$$x : 3 = B$$

$$x^2 : 4 = 2A + C$$

$$\textcircled{5} + \textcircled{5}$$

$$x^3 : 3 = B$$

$$x^4 : 1 = A$$

$$\therefore A = 1, B = 3 \text{ and } C = 2.$$

$$\textcircled{5}$$

15

$$\frac{x^4 + 3x^3 + 4x^2 + 3x + 1}{x(x^2 + 1)^2} = \frac{1}{x} + \frac{3}{x^2 + 1} + \frac{2x}{(x^2 + 1)^2} \quad (10)$$

$$\int \frac{x^4 + 3x^3 + 4x^2 + 3x + 1}{x(x^2 + 1)^2} = \int \frac{1}{x} dx + 3 \int \frac{1}{x^2 + 1} dx + 2 \int \frac{x}{(x^2 + 1)^2} dx. \quad (5)$$

$$= \ln|x| + 3 \tan^{-1} x - \frac{1}{x^2 + 1} + E, \quad \text{where E is an arbitrary constant.}$$

(5) (5) (5) (5)

35

(b)

$$I = \int_0^{\frac{1}{4}} \sin^{-1}(\sqrt{x}) dx$$

$$= x \sin^{-1}(\sqrt{x}) \Big|_0^{\frac{1}{4}} - \int_0^{\frac{1}{4}} x \frac{1}{\sqrt{1-x}} \cdot \frac{1}{2\sqrt{x}} dx. \quad (10)$$

$$= \frac{1}{4} \cdot \frac{\pi}{6} - \frac{1}{2} \int_0^{\frac{1}{4}} \sqrt{\frac{x}{1-x}} dx \quad (5)$$

$$= \frac{\pi}{24} - \frac{1}{2} \int_0^{\frac{1}{4}} \sqrt{\frac{x}{1-x}} dx \quad (5)$$

20

Let $\sqrt{x} = \sin \theta \Rightarrow dx = 2 \sin \theta \cos \theta d\theta$

(5)

$\theta = 0$ when $x = 0$

$\theta = \frac{\pi}{6}$ when $x = \frac{1}{4}$ (5)

$$\int_0^{\frac{1}{4}} \sqrt{\frac{x}{1-x}} dx = \int_0^{\frac{\pi}{6}} \frac{\sin \theta}{\cos \theta} 2 \sin \theta \cos \theta d\theta \quad (5)$$

$$= \int_0^{\frac{\pi}{6}} (1 - \cos 2\theta) d\theta \quad (5)$$

PAPERMASTER.LK

$$= \left(\theta - \frac{1}{2} \sin 2\theta \right) \Big|_0^{\frac{\pi}{6}} \quad (5)$$

$$= \frac{\pi}{6} - \frac{1}{2} \cdot \frac{\sqrt{3}}{2}$$

$$= \frac{\pi}{6} - \frac{\sqrt{3}}{4} \quad (5)$$

$$\therefore I = \frac{\pi}{24} - \frac{1}{2} \left(\frac{\pi}{6} - \frac{\sqrt{3}}{4} \right) = -\frac{\pi}{24} + \frac{\sqrt{3}}{8} = \frac{3\sqrt{3} - \pi}{24}$$

(5)

35

(c)

$$\frac{d}{dx} (x \ln(x^2 + 1) + 2 \tan^{-1} x - 2x)$$

$$= x \left(\frac{1}{x^2 + 1} \right) (2x) + \ln(x^2 + 1) + \frac{2}{1 + x^2} - 2 \quad (10)$$

$$= \ln(x^2 + 1) + \underbrace{\frac{2x^2 + 2 - 2(1 + x^2)}{1 + x^2}}_{=0}$$

$$= \ln(x^2 + 1). \quad (5)$$

15

$$\int \ln(x^2 + 1) dx = x \ln(x^2 + 1) + 2 \tan^{-1} x - 2x + C, \text{ where } C \text{ is an arbitrary constant.} \quad (5)$$

$$\therefore \int_0^1 \ln(x^2 + 1) dx = \ln 2 + 2 \left(\frac{\pi}{4} \right) - 2 \quad (5)$$

$$= \ln 2 + \frac{\pi}{2} - 2$$

$$= \frac{1}{2} (2 \ln 2 + \pi - 4)$$

$$= \frac{1}{2} (\ln 4 + \pi - 4) \quad (5)$$

15

$$\int_0^1 \ln[(x^2 + 1)(x^2 - 2x + 2)] dx$$
$$= \int_0^1 \ln(x^2 + 1) + \int_0^1 \ln(x^2 - 2x + 2) dx \quad (5)$$

Now $\int_0^1 \ln(x^2 - 2x + 2) dx$

$$= \int_0^1 \ln((1-x)^2 - 2(1-x) + 2) dx$$
$$= \int_0^1 \ln(x^2 + 1) dx \quad (5)$$

$$\therefore \int_0^1 \ln[(x^2 + 1)(x^2 - 2x + 2)] dx = 2 \int_0^1 \ln(x^2 + 1) dx$$
$$= \ln 4 + \pi - 4 \quad (5)$$

15

16. Let $P \equiv (x_1, y_1)$ and l be the straight line given by $ax + by + c = 0$. Show that the coordinates of any point on the line through the point P and perpendicular to l are given by $(x_1 + at, y_1 + bt)$, where $t \in \mathbb{R}$.

Deduce that the perpendicular distance from P to l is $\frac{|ax_1 + by_1 + c|}{\sqrt{a^2 + b^2}}$.

Let l be the straight line $x + y - 2 = 0$. Show that the points $A \equiv (0, 6)$ and $B \equiv (3, -3)$ lie on opposite sides of l .

Find the acute angle between l and the line AB .

Find the equations of the circles S_1 and S_2 with centres at A and B , respectively, and touching l .

Let C be the point of intersection of l and the line AB . Find the coordinates of the point C .

Find also the equation of the other common tangent through C to S_1 and S_2 .

Show that the equation of the circle that passes through the origin, bisects the circumference of S_1 and orthogonal to S_2 is $3x^2 + 3y^2 - 38x - 22y = 0$.

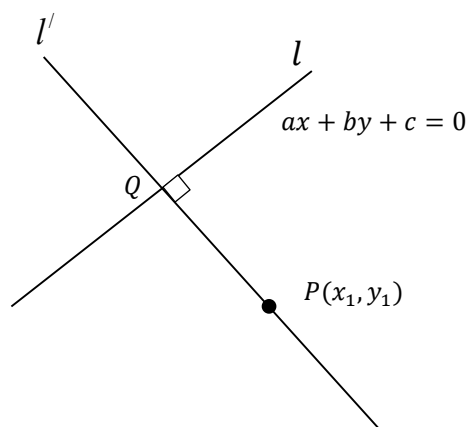

(Note that $a^2 + b^2 \neq 0$)

The equation of l^{\perp} : $y - y_1 = \frac{b}{a} (x - x_1)$. 5

$\therefore \frac{y - y_1}{b} = \frac{x - x_1}{a} = t$ (say) 5

Then $x = x_1 + at$, $y = y_1 + bt$ 5

(This is valid even when $a = 0$ and $b \neq 0$ or when $a \neq 0$ and $b = 0$.)

15

Let $Q \equiv (x_2, y_2) \equiv (x_1 + at_1, y_1 + bt_1)$ be the point of intersection of l and l^\perp .

Since Q is on l , we have $a(x_1 + at_1) + b(y_1 + bt_1) + c = 0$.

$$\therefore t_1 = -\frac{(ax_1 + by_1 + c)}{a^2 + b^2}. \quad (5)$$

The perpendicular distance from P to $l = PQ$

$$= \sqrt{(x_2 - x_1)^2 + (y_2 - y_1)^2} \quad (5)$$

$$= \sqrt{a^2 t_1^2 + b^2 t_1^2}$$

$$= \sqrt{a^2 + b^2} |t_1|. \quad (5)$$

$$= \sqrt{a^2 + b^2} \cdot \frac{|ax_1 + by_1 + c|}{(a^2 + b^2)}$$

$$= \frac{|ax_1 + by_1 + c|}{\sqrt{a^2 + b^2}}. \quad (5)$$

20

$$\ell \quad 2 = 0 \quad (5)$$

$$(0 + 6 - 2)(3 - 3 - 2) = -8 < 0 \quad (5)$$

$\therefore A$ and B lie on opposite sides of ℓ

10

The gradient of $AB = -3 \quad (5)$

The acute angle between ℓ and AB

$$\tan \theta = \left| \frac{-1 - (-3)}{1 + (-1)(-3)} \right| \quad (5)$$

$$\therefore \theta = \tan^{-1} \left(\frac{1}{2} \right) \quad (5)$$

15

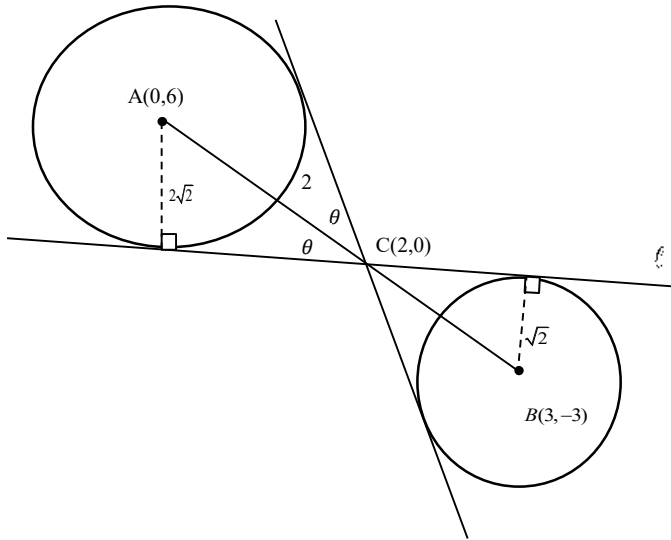

The radius of $S_1 = \frac{|0+6-2|}{\sqrt{2}} = 2\sqrt{2}$ and the radius of $S_2 = \frac{|3-3-2|}{\sqrt{2}} = \sqrt{2}$.

$\therefore S_1 : x^2 + (y-6)^2 = 8$

i.e. $x^2 + y^2 - 12y + 28 = 0$.

$S_2 : (x-3)^2 + (y+3)^2 = 2$

i.e. $x^2 + y^2 - 6x + 6y + 16 = 0$

30

$AC : CB = 2\sqrt{2} : \sqrt{2} = 2 : 1$

$\therefore C \equiv \left(\frac{6+0}{3}, \frac{-6+6}{3} \right) = (2,0)$

Let m be the slope of the other common tangent through C .

$\therefore \tan \theta = \frac{1}{2} = \frac{|m - (-3)|}{|1 + m(-3)|}$

$\Leftrightarrow 1 - 3m = 2m + 6$ or $3m - 1 = 2m + 6$

$\Leftrightarrow m = -1$ or $m = 7$

$\therefore m = 7$.

\therefore The required equation is $y - 0 = 7(x - 2)$.

i.e. $7x - y - 14 = 0$.

25

Let $S \equiv x^2 + y^2 + 2gx + 2fy + c = 0$ be the required circle.

Since S passes through the origin, $c = 0$. (5)

As S bisects the circumference of S_1 , the common chord passes through A .

The common chord is $S - S_1 \equiv 2gx + (2f + 12)y - 28 = 0$ (5)

$A \equiv (0, 6)$ is on $S - S_1 = 0$, we have

$$(2f + 12)(6) - 28 = 0. \quad (5)$$

$$(f + 6)(3) - 7 = 0, \text{ which gives us } f = -\frac{11}{3}. \quad (5)$$

Since S is orthogonal to S_2 , $2g(-3) + 2f(3) = 0 + 16$. (5)

$$\therefore -3g + 3\left(\frac{-11}{3}\right) = 8, \text{ which gives us } \Rightarrow g = -\frac{19}{3}. \quad (5)$$

\therefore The required circle is

$$x^2 + y^2 + 2\left(\frac{-19}{3}\right)x + 2\left(\frac{-11}{3}\right)y = 0 \quad (5)$$

i.e. $3x^2 + 3y^2 - 38x - 22y = 0.$

35

17.(a) Write down $\cos(A+B)$ and $\cos(A-B)$ in terms of $\cos A$, $\cos B$, $\sin A$ and $\sin B$.

Hence, show that $\cos C + \cos D = 2 \cos\left(\frac{C+D}{2}\right) \cos\left(\frac{C-D}{2}\right)$

Deduce that $\cos C - \cos D = -2 \sin\left(\frac{C+D}{2}\right) \sin\left(\frac{C-D}{2}\right)$.

Solve the equation $\cos 9x + \cos 7x + \cot x (\cos 9x - \cos 7x) = 0$.

(b) In the usual notation, state and prove the **Cosine Rule** for a triangle ABC .

Let $x \neq n\pi + \frac{\pi}{2}$ for $n \in \mathbb{Z}$. Show that $\sin 2x = \frac{2 \tan x}{1 + \tan^2 x}$.

In a triangle ABC , it is given that $AB = 20$ cm, $BC = 10$ cm and $\sin 2B = \frac{24}{25}$.

Show that there are two distinct such triangles and find the length of AC for each.

(c) Solve the equation $\sin^{-1}\left[(1+e^{-2x})^{-\frac{1}{2}}\right] + \tan^{-1}(e^x) = \tan^{-1}(2)$.

(a)

$\cos(A+B) = \cos A \cos B - \sin A \sin B$

→ (1) (5)

$\cos(A-B) = \cos A \cos B + \sin A \sin B$

→ (2) (5)

10

(1) + (2)

$\cos(A+B) + \cos(A-B) = 2 \cos A \cos B$ (5)

Taking $A+B=C$ and $A-B=D$, we have $A = \frac{C+D}{2}$, $B = \frac{C-D}{2}$

$\therefore \cos C + \cos D = 2 \cos\left(\frac{C+D}{2}\right) \cos\left(\frac{C-D}{2}\right)$ (5)

10

Now, $\cos C - \cos D = \cos C + \cos(\pi - D)$ (5)

$= 2 \cos\left(\frac{C+(\pi-D)}{2}\right) \cos\left(\frac{C-(\pi-D)}{2}\right)$

$= 2 \sin\left(\frac{D-C}{2}\right) \sin\left(\frac{C+D}{2}\right)$

$= -2 \sin\left(\frac{C-D}{2}\right) \sin\left(\frac{C+D}{2}\right)$ (5)

10

PAPERMASTER.LK

$$\cos 9x + \cos 7x + \cot x (\cos 9x - \cos 7x) = 0 \quad (\sin x \neq 0)$$

$$\therefore 2 \cos 8x \cos x + \frac{\cos x}{\sin x} (-2 \sin 8x \sin x) = 0 \quad (5)$$

$$\therefore \cos x = 0 \text{ or } (\cos 8x - \sin 8x) = 0. \quad (5)$$

$$\therefore \cos x = 0 \text{ or } \tan 8x = 1.$$

$$x = 2m\pi \pm \frac{\pi}{2} \text{ for } m \in \mathbb{Z} \text{ or } 8x = n\pi + \frac{\pi}{4} \text{ for } n \in \mathbb{Z}$$

$$x = 2m\pi \pm \frac{\pi}{2} \text{ for } m \in \mathbb{Z} \text{ or } x = \frac{n\pi}{8} + \frac{\pi}{32} \text{ for } n \in \mathbb{Z}. \quad (5) + (5)$$

20

(b)

Cosine Rule: Let ABC be a triangle. (5)

$$\text{Then } a^2 = b^2 + c^2 - 2bc \cos A$$

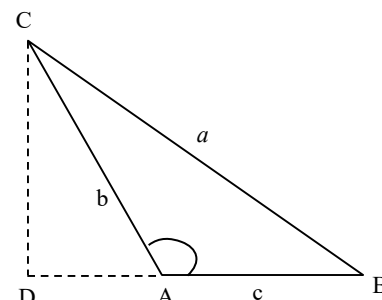
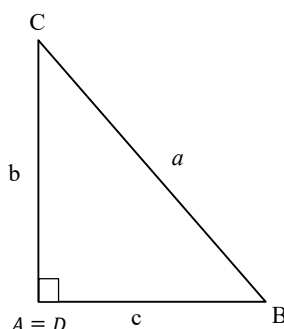
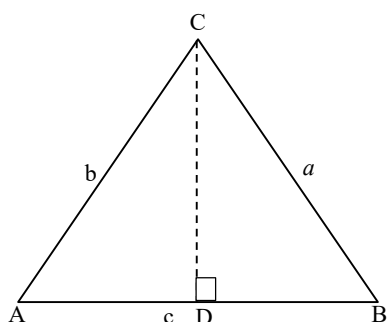

Proof: Let D be the perpendicular of the foot from C on AB . Then by the Pythagoras Theorem.

$$BC^2 = BD^2 + DC^2 \quad (1) \quad (5)$$

Case (i) A is acute;

$$DC = b \sin A$$

$$DB = c - b \cos A \quad (5)$$

Case (ii) A is obtuse

$$DC = b \sin(\pi - A) = b \sin A$$

$$DB = c + b \cos(\pi - A) = c - b \cos A \quad (5)$$

\therefore In both cases, (1) gives us $a^2 = b^2 \sin^2 A + (c - b \cos A)^2$

$$= b^2 \sin^2 A + c^2 - 2bc \cos A + b^2 \cos^2 A$$

$$= b^2 + c^2 - 2bc \cos A \quad (\because \sin^2 A + \cos^2 A = 1) \quad (5)$$

When $A = \frac{\pi}{2}$, $\cos A = 0$ and this holds in that case too. (5)

30

Let $x \neq n\pi + \frac{\pi}{2}$. ($\cos x \neq 0$)

$$\sin 2x = \frac{2 \sin x \cos x}{\cos^2 x} \times \cos^2 x \quad (5)$$

$$= \frac{2 \tan x}{\sec^2 x}$$

$$= \frac{2 \tan x}{1 + \tan^2 x} \quad (5)$$

10

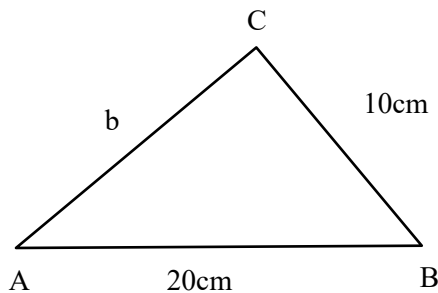

$$\sin 2B = \frac{24}{25} \Rightarrow B \text{ is acute}$$

$$\therefore \frac{2t}{1+t^2} = \frac{24}{25}, \text{ where } t = \tan B \quad (5)$$

$$12t^2 - 25t + 12 = 0$$

$$(4t - 3)(3t - 4) = 0$$

$$t = \frac{3}{4} \text{ or } \frac{4}{3} \quad (5) + (5)$$

\therefore two distinct solutions for B .

\therefore two distinct such triangles.

B is an acute angle $\cos B = \frac{3}{5}$ or $\cos B = \frac{4}{5}$

When $\cos B = \frac{3}{5}$; $AC^2 = (20)^2 + 10^2 - 2(20)(10)\left(\frac{3}{5}\right) \Rightarrow AC = 2\sqrt{65}$. (5)

When $\cos B = \frac{4}{5}$; $AC^2 = (20)^2 + (10)^2 - 2(20)(10)\left(\frac{4}{5}\right) \Rightarrow AC = 6\sqrt{5}$. (5)

25

(c)

Let $\alpha = \sin^{-1}(1 + e^{-2x})^{\frac{1}{2}}$. Since $(1 + e^{-2x})^{\frac{1}{2}} > 0$, α is an acute angle.

Then $\sin \alpha = (1 + e^{-2x})^{\frac{1}{2}} = \frac{e^x}{\sqrt{1 + (e^x)^2}}$

$\therefore \tan \alpha = e^x$. (5)

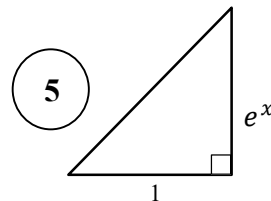

Then, the given equation becomes $\alpha + \alpha = \lambda$.

$$\therefore \frac{2 \tan \alpha}{1 - \tan^2 \alpha} = \tan \lambda \quad (5)$$

$$\Rightarrow \frac{2e^x}{1 - e^{2x}} = 2 \quad (5)$$

$$\Rightarrow e^x = 1 - e^{2x}$$

$$\Rightarrow e^{2x} + e^x - 1 = 0$$

$$\Rightarrow e^x = \frac{-1 \pm \sqrt{5}}{2} \quad (5)$$

Since $e^x > 0$, (-) sign cannot be taken.

$$\therefore e^x = \frac{-1 + \sqrt{5}}{2} \quad (5)$$

$$\therefore x = \ln \left(\frac{\sqrt{5} - 1}{2} \right). \quad (5)$$

Note that this value of x satisfies the given equation.

35

G. C. E (Advanced Level) Examination - 2021(2022)

10 - Combined Mathematics II**Distribution of Marks****Paper II**

$$\text{Part A} \quad = \quad 10 \times 25 \quad = \quad 250$$

$$\text{Part B} \quad = \quad 05 \times 150 \quad = \quad 750$$

$$\text{Total} \quad = \quad \frac{1000}{10}$$

$$\text{Final marks} \quad = \quad 100$$

Common Techniques of Marking Answer Scripts.

It is compulsory to adhere to the following standard method in marking answer scripts and entering marks into the mark sheets.

1. Use a red color ball point pen for marking. (Only Chief/Additional Chief Examiner may use a mauve color pen.)
2. Note down Examiner's Code Number and initials on the front page of each answer script.
3. Write off any numerals written wrong with a clear single line and authenticate the alterations with Examiner's initials.
4. Write down marks of each subsection in a \triangle and write the final marks of each question as a rational number in a \square with the question number. Use the column assigned for Examiners to write down marks.

Example: Question No. 03

(i)	✓	\triangle $\frac{4}{5}$
		
		
(ii)	✓	\triangle $\frac{3}{5}$
		
		
(iii)	✓	\triangle $\frac{3}{5}$
		
		

03

(i) $\frac{4}{5}$

+

(ii) $\frac{3}{5}$

+

(iii) $\frac{3}{5}$

=

$\frac{10}{15}$

MCQ answer scripts: (Template)

1. Marking templates for G.C.E.(A/L) and GIT examination will be provided by the Department of Examinations itself. Marking examiners bear the responsibility of using correctly prepared and certified templates.
2. Then, check the answer scripts carefully. If there are more than one or no answers Marked to a certain question write off the options with a line. Sometimes candidates may have erased an option marked previously and selected another option. In such occasions, if the erasure is not clear write off those options too.
3. Place the template on the answer script correctly. Mark the right answers with a 'v' and the wrong answers with a 'X' against the options column. Write down the number of correct answers inside the cage given under each column. Then, add those numbers and write the number of correct answers in the relevant cage.

Structured essay type and assay type answer scripts:

1. Cross off any pages left blank by candidates. Underline wrong or unsuitable answers. Show areas where marks can be offered with check marks.
2. Use the right margin of the overland paper to write down the marks.
3. Write down the marks given for each question against the question number in the relevant cage on the front page in two digits. Selection of questions should be in accordance with the instructions given in the question paper. Mark all answers and transfer the marks to the front page, and write off answers with lower marks if extra questions have been answered against instructions.
4. Add the total carefully and write in the relevant cage on the front page. Turn pages of answer script and add all the marks given for all answers again. Check whether that total tallies with the total marks written on the front page.

Preparation of Mark Sheets.

Except for the subjects with a single question paper, final marks of two papers will not be calculated within the evaluation board this time. Therefore, add separate mark sheets for each of the question paper. Write paper 01 marks in the paper 01 column of the mark sheet and write them in words too. Write paper II Marks in the paper II Column and write the relevant details.

Part A

1. A particle P of mass m and a particle Q of mass $2m$ moving on a smooth horizontal table along the same straight line towards each other with speeds $4u$ and u , respectively, collide directly. The coefficient of restitution between P and Q is $\frac{4}{5}$. Show that the particles P and Q move away from each other after the collision. Find the time taken, after the collision, for P and Q to be at a distance a apart.

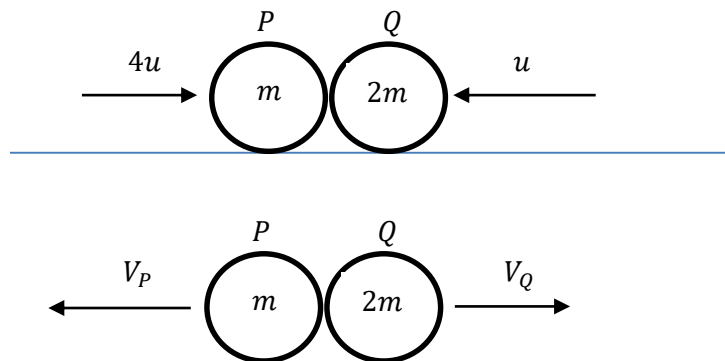
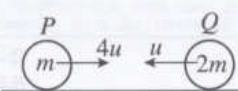

$\underline{I} = \Delta(m\underline{V})$ for the system:

$$0 = (2mV_Q - mV_P) - (4mu - 2mu) \quad (5)$$

$$\Rightarrow 2V_Q - V_P = 2u \quad (1)$$

$I = \Delta(m\underline{v})$ for P and Q

By Newton's Experimental Law,

$$V_Q + V_P = \frac{4}{5}(4u + u) \quad (5)$$

$$V_Q + V_P = 4u \quad (2)$$

$$\therefore V_Q = 2u \text{ and } V_P = 2u. \quad (5)$$

Newton's Experimental Law

For both V_p and V_Q

$(1) + (2): V_Q > 0 \text{ and } V_P > 0.$

$\therefore P$ and Q move away from each other after the collision. (5)

For both $V_p > 0$ and $V_Q > 0$ or equivalent

$$\underline{V}(P, Q) = \underline{V}(P, E) + \underline{V}(E, Q)$$

$$= \overline{2u} + \overline{2u}$$

$$= 4u \quad \leftarrow$$

The required time = $\frac{a}{4u}$. (5)

$\frac{a}{4u}$ seen.

2. A particle is projected from a point O at a vertical distance a above a horizontal ground with initial velocity \sqrt{ga} and at an angle α ($0 < \alpha < \frac{\pi}{2}$) to the horizontal, as shown in the figure. The particle strikes the ground at a horizontal distance a from O . Show that $\tan \alpha = 1 + \sqrt{2}$.

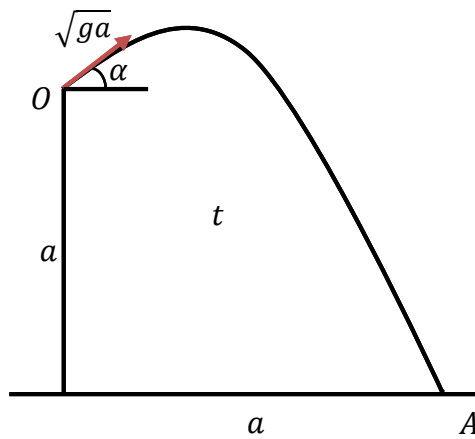
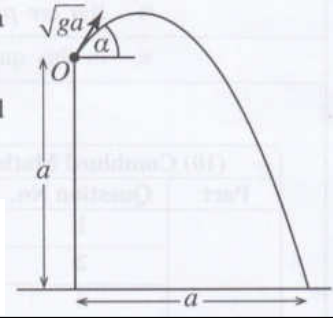

From O to A $S = ut + \frac{1}{2}at^2$:

$\rightarrow a = \sqrt{ga} \cos \alpha t$ ----- (1) **5**

$\rightarrow s = u + \frac{1}{2}at^2$

$\uparrow -a = \sqrt{ga} \sin \alpha t - \frac{1}{2}gt^2$ ----- (2) **5**

$\uparrow s = u + \frac{1}{2}at^2$

① given us $t = \frac{a}{\sqrt{ga} \cos \alpha}$.

② given us $-a = a \tan \alpha - \frac{1}{2}g \frac{a^2}{ga \cos^2(\alpha)}$.

$\therefore -2 = 2 \tan \alpha - (1 + \tan^2 \alpha)$. **5**

For the quadratic in $\tan \alpha$

i.e. $\tan^2 \alpha - 2 \tan \alpha - 1 = 0$.

$\therefore \tan \alpha = \frac{-2 \pm \sqrt{4 + 4}}{2} = 1 \pm \sqrt{2}$ **5**

both \pm

(-) sign is not possible as $0 < \alpha < \frac{\pi}{2}$.

$\therefore \tan \alpha = 1 + \sqrt{2}$. **5**

Selecting the correct sign

3. A particle P of mass m is placed on a smooth horizontal table and is connected to a light smooth pulley Q by a light inextensible string which passes over a fixed small smooth pulley at the point A of the edge of the table. A light inextensible string which passes over the pulley Q is connected to particles of masses $2m$ and $3m$, as shown in the figure. The particles and the strings lie in a vertical plane. The system is released from rest with the strings taut. Obtain equations sufficient to determine the acceleration of Q .

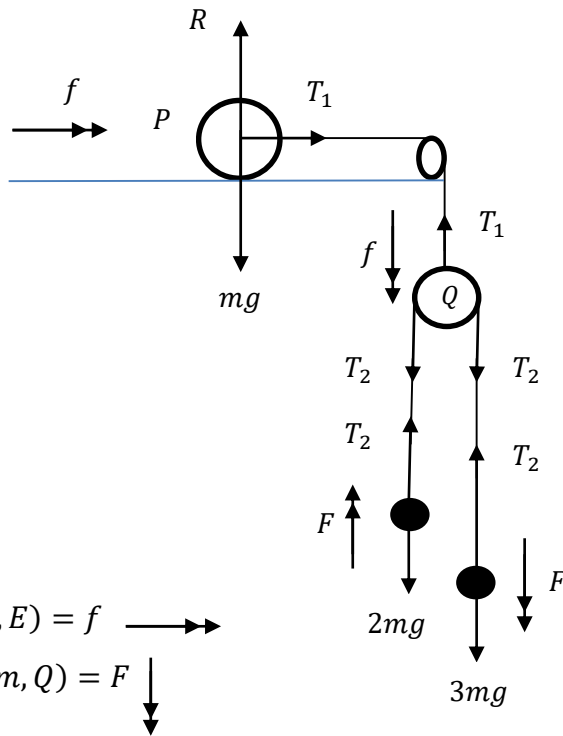
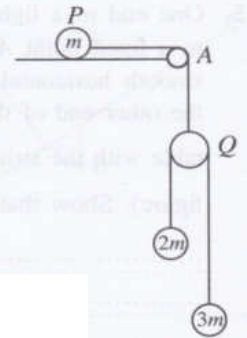

$$\underline{a}(P, E) = f \longrightarrow$$

$$\underline{a}(3m, Q) = F \downarrow$$

5

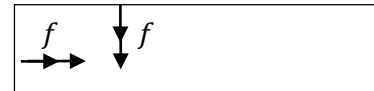

Applying $\underline{F} = m\underline{a}$:

$(P) \longrightarrow T_1 = mf$ (5)

$\underline{F} = m\underline{a}$ for P

$(Q) \downarrow 2T_2 - T_1 = 0$ (5)

$\underline{F} = m\underline{a}$ for Q

$(2m) \uparrow T_2 - 2mg = 2m(F - f)$ (5)

$\underline{F} = m\underline{a}$ for $2m$

$(3m) \downarrow 3mg - T_2 = 3m(F + f)$ (5)

$\underline{F} = m\underline{a}$ for $3m$

or

$(Q) (2m) \text{ and } (3m) \downarrow T_1 - 2mg - 3mg = 2m(f - F) - 3m(f + F)$

$\underline{F} = m\underline{a}$ for $Q, 2m$ and $3m$

Note: Any 4 correct independent equations

20

25

4. A car of mass M kg moves upwards with a constant acceleration along a straight road of inclination $\sin^{-1}\left(\frac{1}{20}\right)$ to the horizontal. There is a constant resistance of R N to its motion. The distance travelled by the car to increase its speed from 36 km h^{-1} to 72 km h^{-1} is 500 m. Obtain equations sufficient to determine the power exerted by the car when its speed is 54 km h^{-1} .

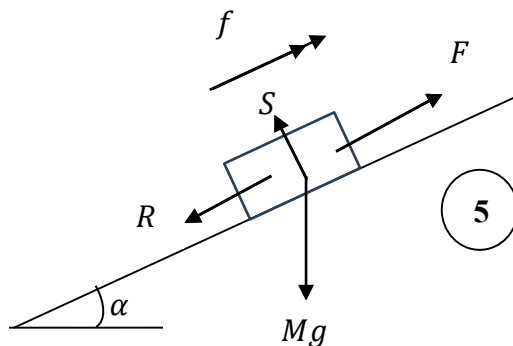

For forces with or without S

$$\sin \alpha = \frac{1}{20}$$

$$\frac{36 \times 1000}{3600} = 10 \text{ ms}^{-1}$$

$$\frac{72 \times 1000}{3600} = 20 \text{ ms}^{-1} \quad (5)$$

For all three conversions of speeds

$$\frac{54 \times 1000}{3600} = 15 \text{ ms}^{-1}$$

$$\begin{aligned} \nearrow v^2 &= u^2 + 2as: \\ 20^2 &= 10^2 + 2f(500) \quad (5) \end{aligned}$$

Applying $v^2 = u^2 + 2as$ \nearrow

$$f = \frac{150}{500} = \frac{3}{10} \text{ ms}^{-2}$$

$$\begin{aligned} \nearrow \underline{F} &= m\underline{a}: \\ F - R - Mg \sin \alpha &= Mf \quad (5) \end{aligned}$$

Applying $\underline{F} = m\underline{a}$ \nearrow

$$\begin{aligned} P &= F \cdot V \\ &= F \cdot 15 \quad (5) \end{aligned}$$

$P = F \cdot 15$ seen

25

5. One end of a light inextensible string of length $2a$ is attached to a fixed point A which is at a distance a vertically above a smooth horizontal table. A particle P of mass m , attached to the other end of the string, moves in a horizontal circle on the table with the string taut and with uniform speed $\sqrt{\frac{ga}{2}}$ (see the figure). Show that the magnitude of the normal reaction on the particle P from the table is $\frac{5}{6}mg$

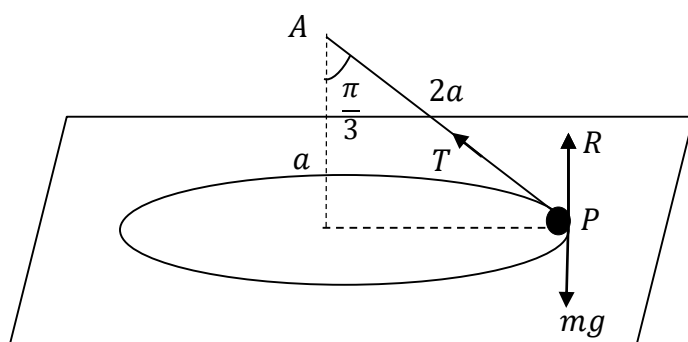
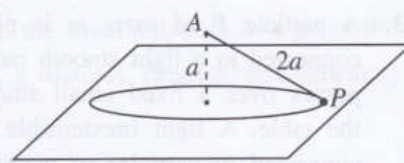

5

For the forces

Applying $\underline{F} = m\underline{a}$:

$$\leftarrow T \sin \frac{\pi}{3} = m \cdot \frac{ga}{2(2a \sin \frac{\pi}{3})} \quad (5)$$

$$\underline{F} = m\underline{a} \quad \leftarrow$$

$$\therefore T = \frac{mg}{3} \quad (5)$$

$$T = \frac{mg}{3} \text{ seen or implied}$$

$$\uparrow R - mg + T \cos \frac{\pi}{3} = 0 \quad (5)$$

$$\underline{F} = m\underline{a} \quad \uparrow$$

$$\therefore R = mg - \frac{mg}{6}$$

$$= \frac{5}{6}mg \quad (5)$$

Work leading to the answer

25

6. In the usual notation, the position vectors of two points A and B , with respect to a fixed origin O are $2\mathbf{i} - 3\mathbf{j}$ and $\mathbf{i} - 2\mathbf{j}$, respectively. Using $\overrightarrow{AO} \cdot \overrightarrow{AB}$, find $O\hat{A}B$.
Let C be the point on OA such that $O\hat{C}B = \frac{\pi}{2}$. Find \overrightarrow{OC} .

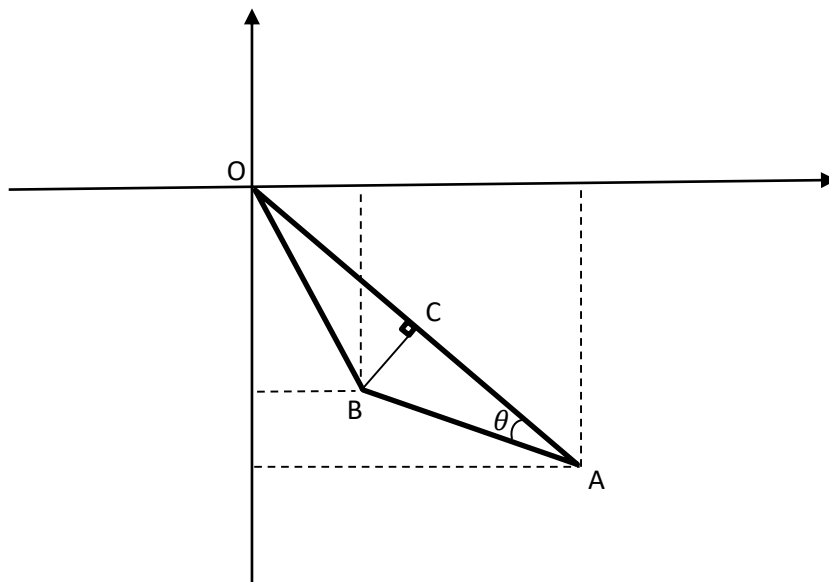

$$\overrightarrow{OA} = 2\mathbf{i} - 3\mathbf{j} \text{ and } \overrightarrow{OB} = \mathbf{i} - 2\mathbf{j}$$

$$\therefore \overrightarrow{AO} = -2\mathbf{i} + 3\mathbf{j} \text{ and}$$

$$\overrightarrow{AB} = (\mathbf{i} - 2\mathbf{j}) - (2\mathbf{i} - 3\mathbf{j}) \quad (5)$$

$$= -\mathbf{i} + \mathbf{j}$$

\overrightarrow{AO} is terms of \mathbf{i} and \mathbf{j}

$$\overrightarrow{AO} \cdot \overrightarrow{AB} = |\overrightarrow{AO}| |\overrightarrow{AB}| \cos \theta \quad (5)$$

Definition of $\overrightarrow{AO} \cdot \overrightarrow{AB}$ or equivalent

$$2 + 3 = \sqrt{13}\sqrt{2} \cos \theta$$

$$\therefore \cos \theta = \frac{5}{\sqrt{26}} \quad (5)$$

$\cos \theta = \frac{5}{\sqrt{26}}$ seen

$$\therefore \theta = \cos^{-1}\left(\frac{5}{\sqrt{26}}\right)$$

$$\overrightarrow{OC} = \lambda \overrightarrow{OA}, \text{ where } \lambda \in \mathbb{R}, \text{ and } \overrightarrow{CB} = (\mathbf{i} - 2\mathbf{j}) - \lambda(2\mathbf{i} - 3\mathbf{j})$$

condition for $O\hat{C}B = \frac{\pi}{2}$ using dot product

$$\overrightarrow{OA} \cdot \overrightarrow{CB} = 0 \text{ gives as } 2(1 - 2\lambda) - 3(-2 + 3\lambda) = 0 \quad (5)$$

$$\therefore \lambda = \frac{8}{13} \quad (5)$$

value of λ or equivalent

and
$$\overrightarrow{OC} = \frac{8}{13} (2\mathbf{i} - 3\mathbf{j})$$

25

7. A uniform rod AB of length $8a$ and weight W has its end A smoothly hinged to a fixed point. One end of a light inextensible string of length $4a$ is attached to the point C on the rod such that $AC = 3a$, and the other end is attached to a fixed point D vertically above A such that $AD = 5a$ (see the figure). The rod is in equilibrium. Show that the tension of the string is $\frac{16}{15}W$. Also, find the horizontal component of the reaction at A .

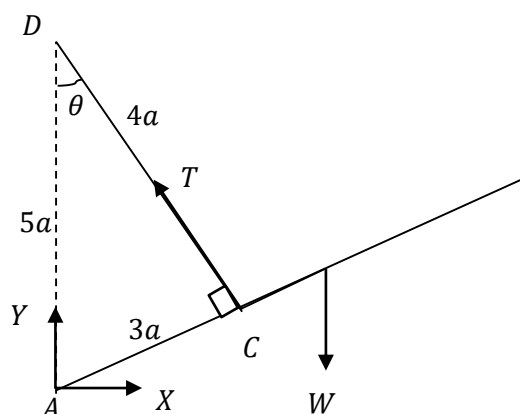
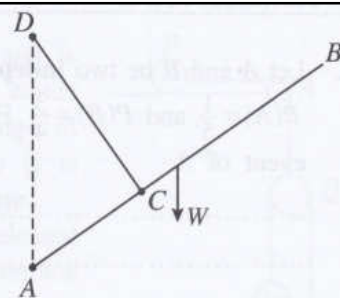

5

For the forces

$$\hat{ACD} = \frac{\pi}{2}$$

5

For the equilibrium of the rod:

$$\hat{ACD} = \frac{\pi}{2} \text{ seen}$$

$$\curvearrowleft A \quad W \times 4a \cos \theta - T \times 3a = 0 \quad 5$$

An equation sufficient to find T .

$$\therefore T = \frac{4W}{3} \cos \theta$$

$$= \frac{4W}{3} \times \frac{4}{5} = \frac{16W}{15} \quad 5$$

work leading to the answer

$$\rightarrow X = T \sin \theta$$

$$= \frac{16W}{15} \times \frac{3}{5}$$

$$= \frac{16W}{25} \quad 5$$

$$\frac{16W}{25} \text{ seen.}$$

25

8. A particle P of mass m is placed on a rough plane inclined at an angle $\frac{\pi}{4}$ to the horizontal. One end of a light inextensible string which passes over a fixed small smooth pulley fixed to the edge of the inclined plane at A , is attached to the particle P and the other end to a particle Q of mass λmg , as shown in the figure. The coefficient of friction between the particle P and the inclined plane is $\frac{1}{2}$. The line PA is a line of greatest slope of the inclined plane and the particles P and Q stay in equilibrium with the string taut.

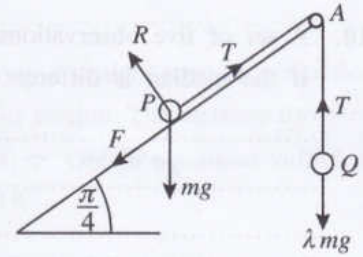

Show that $\frac{1}{2\sqrt{2}} \leq \lambda \leq \frac{3}{2\sqrt{2}}$. (The relevant forces are marked in the figure.)

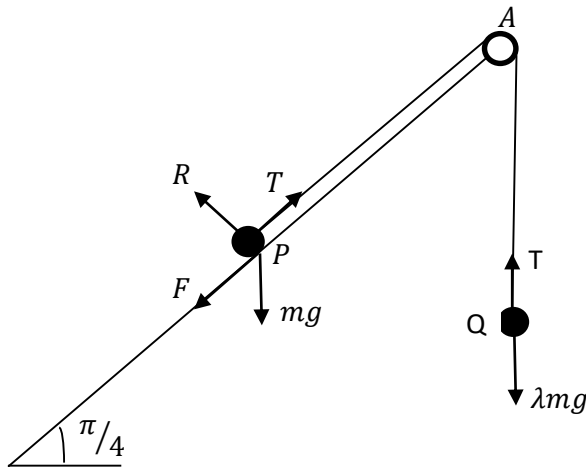

For the equilibrium:

(P) $R - mg \cos\left(\frac{\pi}{4}\right) = 0$ (5)

$\therefore R = \frac{mg}{\sqrt{2}}$

An equation leading to the value of R .

(Q) $T - \lambda mg = 0$ (5)

$\therefore T = \lambda mg$

An equation leading to the value of T .

(P) $T - F - mg \sin\left(\frac{\pi}{4}\right) = 0$ (5)

$\therefore F = \lambda mg - \frac{mg}{\sqrt{2}} = \frac{mg}{\sqrt{2}}(\sqrt{2}\lambda - 1)$

An equation leading to the value of F .

For the equilibrium of P :

$\frac{1}{2} \geq \frac{|F|}{R}$ (5)

$\therefore |\sqrt{2}\lambda - 1| \leq \frac{1}{2}$

Condition for non-slipping with absolute value.

work leading to the answer

(5) $\therefore \frac{1}{2\sqrt{2}} \leq \lambda \leq \frac{3}{2\sqrt{2}}$

25

9. Let A and B be two **independent** events of a sample space Ω . In the usual notation, it is given that $P(A) = \frac{1}{5}$ and $P(B) = \frac{3}{4}$. Find $P(A \cup B)$, $P(A|A \cup B)$ and $P(B|A')$, where A' denotes complementary event of A .

$$P(A) = \frac{1}{5}, P(B) = \frac{3}{4}$$

Since A and B are independent,

$$P(A \cap B) = P(A) \cdot P(B) \quad (5)$$

$$= \frac{3}{20}$$

For the condition for independence

$$P(A \cup B) = P(A) + P(B) - P(A \cap B) \quad (5)$$

$$= \frac{1}{5} + \frac{3}{4} - \frac{3}{20} = \frac{4}{5}$$

Formula a for $P(A \cup B)$

$$P(A|A \cup B) = \frac{P(A \cap (A \cup B))}{P(A \cup B)} = \frac{P(A)}{P(A \cup B)} = \frac{1/5}{4/5} = \frac{1}{4} \quad (5)$$

$\frac{1}{4}$ or equivalent seen.

$$P(B|A') = \frac{P(B \cap A')}{P(A')}$$

$$P(B \cap A') = P(B) - P(A \cap B) = \frac{3}{4} - \frac{3}{20} = \frac{3}{5} \quad (5)$$

$\frac{3}{5}$ or equivalent seen.

$$\left(\boxed{\text{OR}} \right) P(B \cap A') = P(B) \cdot P(A') = \frac{3}{4} \times \frac{4}{5} = \frac{3}{5}$$

$$P(B|A') = \frac{3/5}{4/5} = \frac{3}{4} \quad (5)$$

$\frac{3}{4}$ or equivalent seen.

25

10. A set of five observations of positive integers has mean 6 and range 10. It has two modes. If the median is different from the modes, find the five observations.

Let the numbers in the increasing order be

$$a, a, b, c, c$$

Since the range is 10, we have $c - a = 10$.

5

Condition for the range

$$\therefore c = a + 10 \quad \text{—————(1)}$$

Since the mean is 6, we have $\frac{2a+b+2c}{5} = 6$.

5

For this or an equivalence

(1) and (2) gives us $4a + b + 20 = 30$

$$i.e. \quad 4a + b = 10 \quad \text{—————(3)}$$

5

An equation sufficient to determine the observations

Since a and b are positive integers,

Then, (3) implies that $4a \leq 9$ and the only possible values for a are 1 and 2.

If $a = 1$, then $b = 6$.

If $a = 2$, then $b = 2$, and it is not possible as the median is different from the modes.

5

Mean \neq mode used.

\therefore The numbers are 1, 1, 6, 11, 11.

5

1, 1, 6, 11, 11 seen.

25

11.(a) A particle P , projected with a velocity $u \text{ m s}^{-1}$ vertically upwards from a point O , reaches a point A after 4 seconds and comes back to A again after another 2 seconds. At the instant when the particle P is at A for the second time, another particle Q is projected with the same velocity $u \text{ m s}^{-1}$ vertically upwards from O . Sketch the velocity-time graph for the motions of P and Q , in the same diagram.

Hence, find the value of u and the height of OA in terms of g , and the time taken by Q to collide with P .

(b) A ship S is sailing due north with uniform speed $u \text{ km h}^{-1}$ relative to earth. At a certain instant, a boat P is at a distance $d \text{ km}$ east of S and another boat Q is at a distance $\sqrt{3}d \text{ km}$ south of S . The boat P travels in a straight line path intending to intercept S with uniform speed $2u \text{ km h}^{-1}$ relative to earth and the boat Q travels in a straight line path intending to intercept P with uniform speed $3u \text{ km h}^{-1}$ relative to earth.

Show that

(i) the time taken by the boat P to intercept the ship S is $\frac{d}{\sqrt{3}u} \text{ h}$,

(ii) the boat P intercepts the ship S before the boat Q intercepts the boat P .

(a)

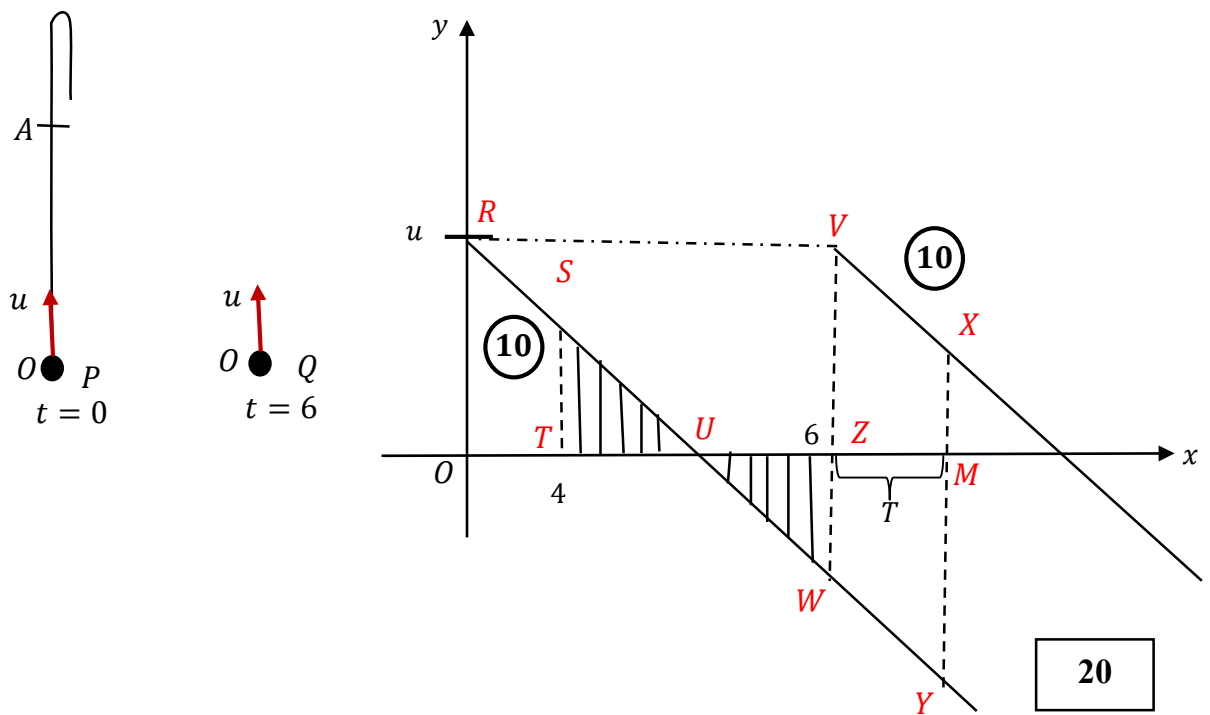

Since Area $\Delta STU = \text{Area } \Delta UZW$,

we have $TU = UZ$.

$TZ = 2 \Rightarrow TU = 1$. (5)

$\therefore OU = 5$. (5)

PAPERMASTER.LK

From ΔROU , we have $g = \frac{u}{5}$.

$$\therefore u = 5g. \quad (5)$$

From ΔSTU , we have $g = \frac{ST}{1} = ST. \quad (5)$

The height of $OA = \text{Area of } ORST.$

$$= \frac{1}{2}(OR + ST) \times OT \quad (5)$$

$$= \frac{1}{2}(u + g) \times 4 \quad (5)$$

$$= \frac{1}{2} \times 6g \times 4$$

$$= 12g \quad (5)$$

Let T be the time taken by Q to collide with P .

$$OA = \text{Area } VZMX + \text{Area } WZMY$$

$$= \text{Area } VWYX \quad (10)$$

$$= \frac{1}{2}(VW + XT) \times ZM$$

$$\therefore 12g = \frac{1}{2}(6g + 6g) \times T \quad (10)$$

$$\therefore T = 2 \text{ sec.} \quad (5)$$

60

(b)

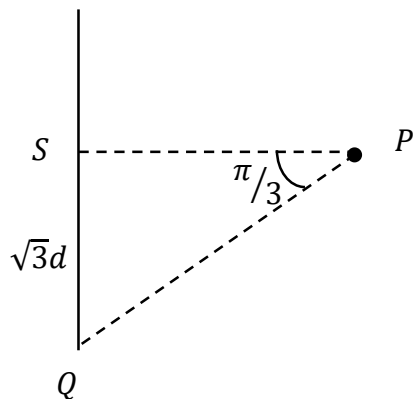

$$\underline{V}(S, E) = \uparrow u$$

$$\underline{V}(P, E) = 2u$$

$$\underline{V}(Q, E) = 3u$$

$$\underline{V}(P, S) = \leftarrow$$

$$\underline{V}(Q, P) = \begin{array}{c} \nearrow \\ \pi/3 \end{array}$$

(i)

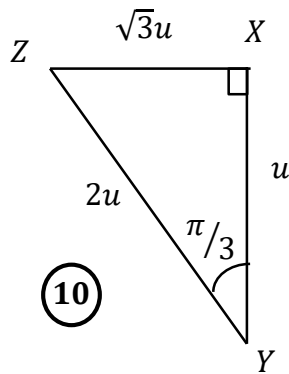

$$\begin{aligned} \underline{V}(P, S) &= \underline{V}(P, E) + \underline{V}(E, S) && \textcircled{5} + \textcircled{5} \\ &= \underline{V}(E, S) + \underline{V}(P, E) \\ &= \overline{XY} + \overline{YZ} \\ &= \overline{XZ} \end{aligned}$$

The required time = $\frac{d}{XZ} = \frac{d}{\sqrt{3}u} h.$ $\textcircled{5}$

25

(ii)

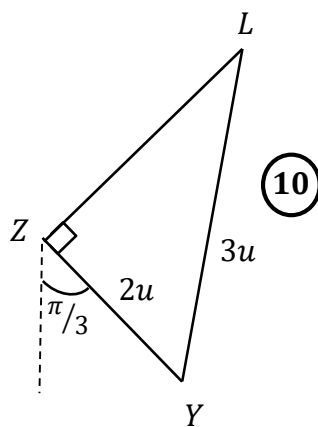

$$\begin{aligned} \underline{V}(Q, P) &= \underline{V}(Q, E) + \underline{V}(E, P) && \textcircled{5} \\ &= \underline{V}(E, P) + \underline{V}(Q, E) \\ &= \overline{ZY} + \overline{YL} \\ &= \overline{ZL} \end{aligned}$$

$$ZL = \sqrt{(3u)^2 - (2u)^2} = \sqrt{5}u \quad \textcircled{5}$$

Let t_2 be the time taken by Q to intercept P .

$$\begin{aligned} \text{Then, } t_2 &= \frac{\sqrt{3} d \sec(\pi/6)}{\sqrt{5} u} \\ &= \frac{2d}{\sqrt{5} u} h. && \textcircled{10} \end{aligned}$$

$$\therefore t_1 < t_2. \quad \textcircled{10}$$

70

12.(a) Equilateral triangle ABC in the figure is the vertical cross-section through the centre of gravity of a smooth uniform wedge of mass $3m$ with $AB = BC = AC = 6a$ such that the face containing BC is placed on a smooth horizontal floor. The lines AB and AC are lines of greatest slope of the faces containing those. The point D is a fixed point on the vertical wall which is at a distance a from the point B of the wedge, and in the plane of ABC such that AD is horizontal. One end of a light inextensible string of length $5a$ passing over a small smooth pulley fixed at A is attached to a particle P of mass $2m$ kept on AC and the other end is attached to the fixed point D on the wall. A particle Q of mass m is held on AB . The system is released from the rest with $AP = AQ = a$, as shown in the figure. Obtain equations sufficient to determine the velocity of Q relative to the wedge at the instant when the wedge strikes the wall.

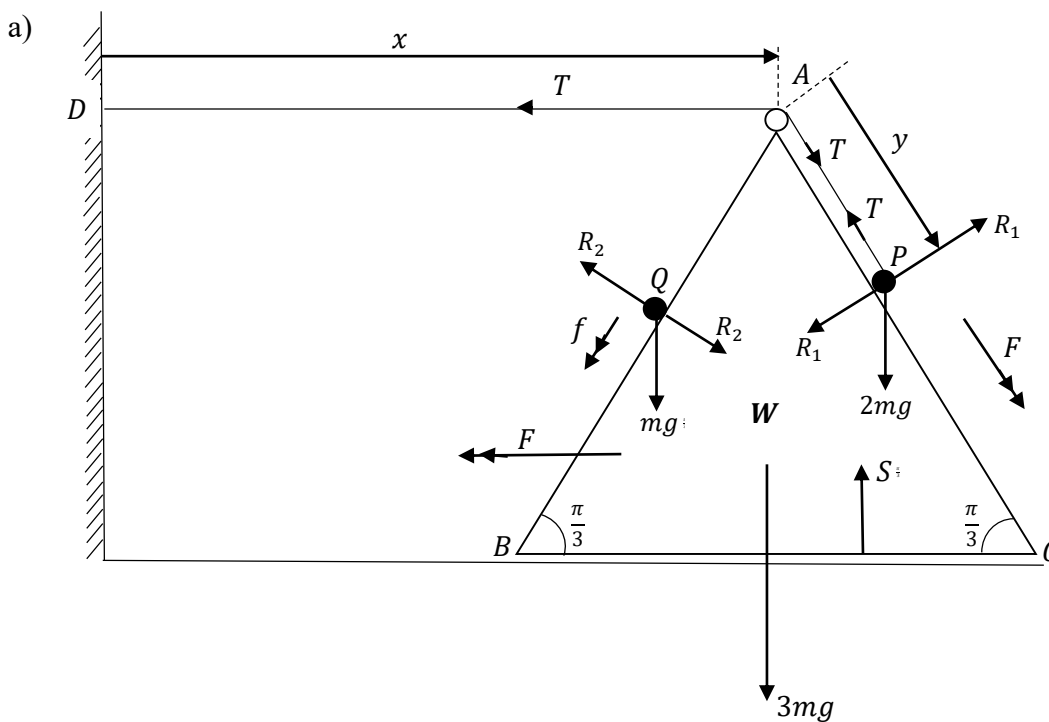
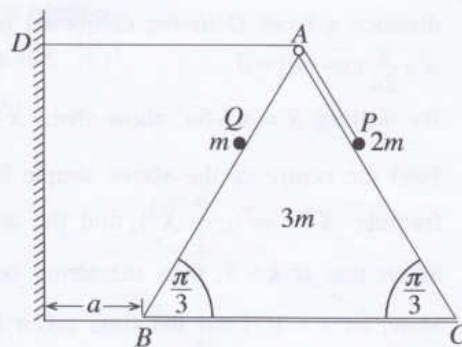

$$x + y = \text{constant.} \quad (5)$$

$$\therefore \ddot{x} + \ddot{y} = 0. \quad (1) \quad (5)$$

Let $\underline{a}(W, E) = F \leftarrow$

$$\therefore \underline{a}(P, W) = F \searrow \quad (\text{by (1)}) \quad (5)$$

Also, let $\underline{a}(Q, W) = f \swarrow$

PAPERMASTER.LK

Applying $\underline{F} = m\underline{a}$:

$$\textcircled{P} \searrow \quad \textcircled{5} \text{ (for forces)} \quad \textcircled{5} \text{ (for acceleration)} \\ 2mg \sin\left(\frac{\pi}{3}\right) - T = 2m\left(F - F \cos\left(\frac{\pi}{3}\right)\right) \quad \textcircled{5} \text{ (for equation)}$$

$$\textcircled{Q} \swarrow \quad mg \sin\left(\frac{\pi}{3}\right) = m\left(f + F \cos\left(\frac{\pi}{3}\right)\right) \quad \textcircled{5} \text{ (for equation)}$$

$$\textcircled{5} \qquad \qquad \qquad \textcircled{5}$$

For the system (P , Q , and W), \longleftarrow

$$T = 3mF + 2m\left(F - F \cos\left(\frac{\pi}{3}\right)\right) + m\left(F + f \cos\left(\frac{\pi}{3}\right)\right) \quad \textcircled{5} \text{ (for equation)}$$

$$\textcircled{5} \quad \textcircled{5} \qquad \qquad \textcircled{5} \qquad \qquad \textcircled{5}$$

Applying $S = ut + \frac{1}{2}at^2$:

$$\longleftarrow \textcircled{W} \quad a = \frac{1}{2}ft^2 \quad \textcircled{5}$$

Applying $v = u + at$:

$$v = Ft \quad \textcircled{5}$$

(b) A thin wire $ABCDEF$ is fixed in a vertical plane, as shown in the figure. The portion ABC is a thin **smooth** semicircular wire with centre O and radius a . The portion CD is a thin **rough** horizontal wire of length a . The portion DEF is also a thin **smooth** semicircular wire of radius a . The diameters AC and DF are vertical. A small smooth bead P of mass m is placed at A and is given a velocity u ($>3\sqrt{ag}$) horizontally, and begins to move along the wire. It is given that the magnitude of the frictional force on the bead from the wire, during its motion from C to D , is $\frac{1}{2}mg$. Show that the speed v of the bead P , during its motion from A to C , when \overrightarrow{OP} makes an angle θ ($0 \leq \theta \leq \pi$) with \overrightarrow{OA} , is given by $v^2 = u^2 - 2ag(1 - \cos \theta)$.

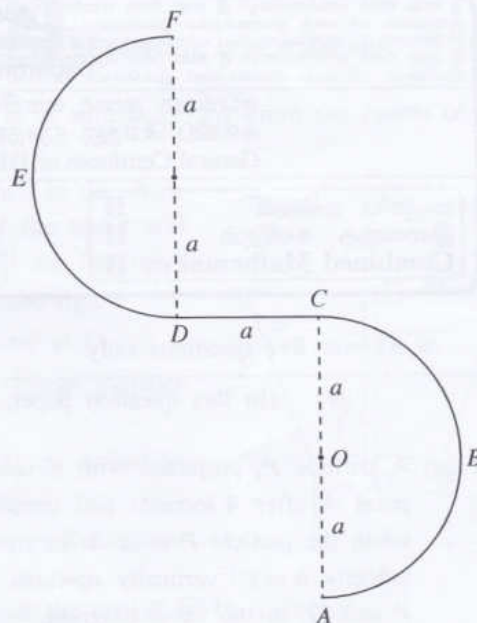

Show that the speed w of the bead P just before it leaves the wire at F is given by $w^2 = u^2 - 9ag$, and find the reaction on the bead P from the wire at that instant.

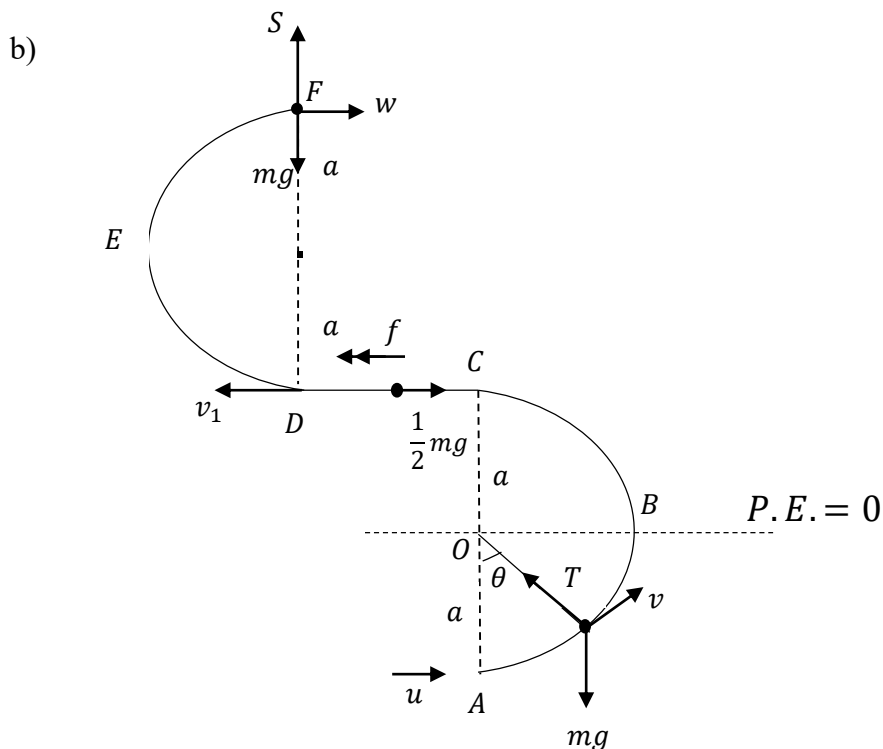

By the conservation of energy,

$$\frac{1}{2}mv^2 - mga \cos \theta = \frac{1}{2}mu^2 - mga \quad (15) \quad \boxed{\text{PE (5)+KE (5)+Equation (5)}}$$

$$\therefore v^2 = u^2 - 2ga(1 - \cos \theta) \quad (5)$$

$$\text{When } \theta = \pi, v^2 = u^2 - 4ga \quad (1) \quad (5)$$

25

From C to D, $\leftarrow \underline{F} = m\underline{a}$:

$$-\frac{1}{2}mg = mf \quad (5)$$

$$\therefore f = -\frac{g}{2} \quad (5)$$

$$\begin{aligned} \leftarrow v^2 = u^2 + 2as : v_1^2 &= (u^2 - 4ga) - 2 \cdot \frac{g}{2} a \\ &= u^2 - 5ga. \quad (10) \end{aligned}$$

$$\text{Using (1), we have } w^2 = v_1^2 - 4ga \quad (10)$$

$$= u^2 - 9ga. \quad (5)$$

$\underline{F} = m\underline{a}$ \downarrow at F:

$$mg - S = m \frac{w^2}{a} \quad (5)$$

$$\therefore S = mg - \frac{m}{a}(u^2 - 9ga)$$

$$= \frac{m}{a}(10ag - u^2) \quad (5)$$

45

13. One end of a light elastic string of natural length $4a$ is attached to a fixed point O and the other end to a particle P of mass m . The particle hangs in equilibrium at a distance $5a$ below O .

Show that the modulus of elasticity of the string is $4mg$.

Now, another particle Q of mass m moving vertically upwards collides and coalesces with P , and form a combined particle R . The speed of the particle Q just before it collides with the particle P is $\sqrt{2kga}$. Find the velocity with which R begins to move.

Show that, in the subsequent motion while the string is not slack, the distance x from O to the combined particle R satisfies the equation $\ddot{x} + \frac{g}{2a}(x - 6a) = 0$.

By writing $X = x - 6a$, show that, $\ddot{X} + w^2X = 0$ where $w = \sqrt{\frac{g}{2a}}$.

Find the centre of the above simple harmonic motion and using the formula $\dot{X}^2 = w^2(c^2 - X^2)$, find the amplitude c .

Show that if $k > 3$, then the string becomes slack,

Now, let $k = 8$. Find the time taken by the combined particle R to strike an **inelastic horizontal floor** at a distance $\frac{15}{2}a$ below the point O , from the instant of coalescing of the particles P and Q .

Also, find the maximum height reached by the combined particle R after striking the floor.

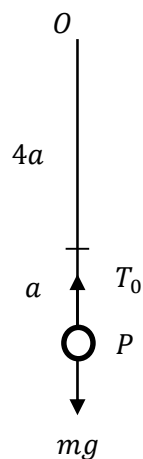
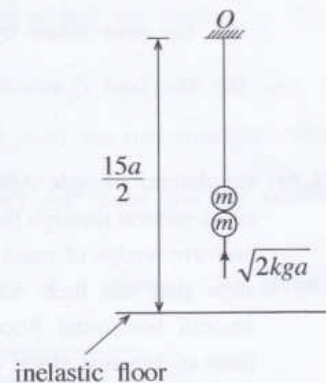

For the equilibrium of P ,

$$\uparrow T_0 = mg \quad (5)$$

$$T_0 = \frac{\lambda a}{4a} = \frac{\lambda}{4} \quad (5)$$

$$\therefore \lambda = 4mg$$

(5)

15

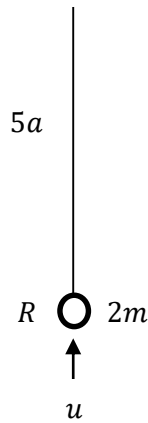
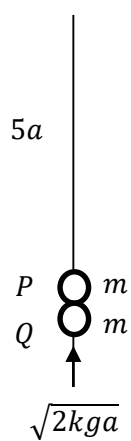

Applying $\underline{I} = \Delta(m\underline{v})$ for P and Q:

$$\uparrow 0 = 2mu - m\sqrt{2kga} \quad (5)$$

$$\therefore u = \sqrt{\frac{kga}{2}} \quad (5)$$

10

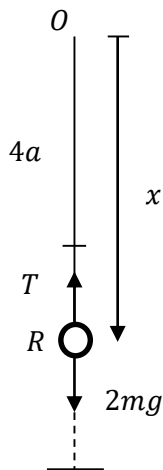

Applying $\underline{F} = m\underline{a}$ for R:

$$\uparrow T - 2mg = -2m\ddot{x} \quad (10)$$

$$T = 4mg \frac{(x - 4a)}{4a} \quad (5)$$

$$\therefore \frac{mg}{a}(x - 4a) - 2mg = -2m\ddot{x}$$

$$\ddot{x} + \frac{g}{2a}(x - 6a) = 0 \quad (1) \quad (5)$$

20

$$X = x - 6a$$

$$\therefore \dot{X} = \dot{x}$$

$$\therefore \ddot{X} = \ddot{x} \quad (5)$$

$$\text{Then (1)} \Rightarrow \ddot{X} + \omega^2 X = 0, \text{ where } \omega = \sqrt{\frac{g}{2a}}. \quad (5)$$

10

Centre is given by $X = 0$.

i.e. $x = 6a$. (5)

$$\dot{X}^2 = \omega^2(c^2 - X^2) \text{.....(2)}$$

When $x = 5a$, we have $X = -a$ and $\dot{X} = -\frac{1}{2}\sqrt{2kga}$. (5)

$$\text{Then (2)} \Rightarrow \frac{kga}{2} = \frac{g}{2a}(c^2 - a^2).$$

$$\Rightarrow ka^2 = c^2 - a^2.$$

$$\Rightarrow c = \sqrt{k+1} a. \quad (5)$$

15

Let $k > 3$. Then, $c > 2a$.

\therefore Amplitude $> 2a$. (5)

\therefore the string becomes slack. (5)

10

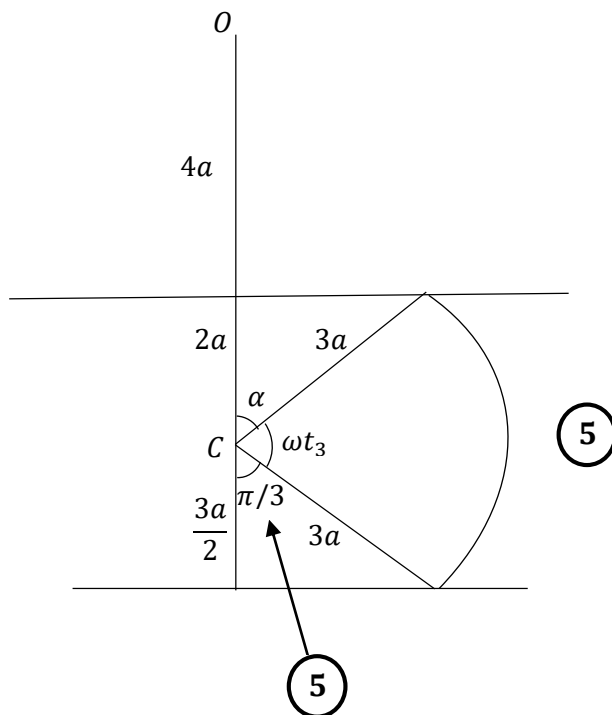

$$\omega t_3 = \frac{2\pi}{3} - \alpha \quad (5)$$

$$\therefore t_3 = \frac{1}{\omega} \left(\frac{2\pi}{3} - \alpha \right)$$

\therefore The required time = $t_1 + t_2 + t_3$

$$= \frac{1}{\omega} (\beta - \alpha) + \sqrt{\frac{10a}{g}} + \frac{1}{\omega} \left(\frac{2\pi}{3} - \alpha \right)$$

$$= \sqrt{\frac{10a}{g}} + \sqrt{\frac{2a}{g}} \left\{ \frac{2\pi}{3} + \cos^{-1} \left(\frac{1}{3} \right) - 2 \cos^{-1} \left(\frac{2}{3} \right) \right\} \quad (10)$$

60

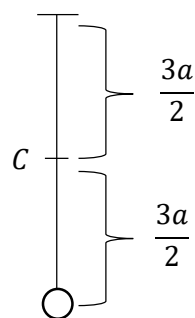

After hitting the floor, R performs only simple harmonic motion. 5

$$\therefore \text{The maximum height} = \frac{3a}{2} + \frac{3a}{2}$$

$$= 3a \quad (5)$$

10

14. (a) Let \mathbf{a} and \mathbf{b} be non-zero and non-parallel vectors, and $\lambda, \mu \in \mathbb{R}$.
 Show that if $\lambda\mathbf{a} + \mu\mathbf{b} = \mathbf{0}$, then $\lambda = 0$ and $\mu = 0$.
 Let ABC be a triangle. The mid-point of AB is D and the mid-point of CD is E . The lines AE (extended) and BC meet at F . Let $\overrightarrow{AB} = \mathbf{a}$ and $\overrightarrow{AC} = \mathbf{b}$. Using the triangle law of addition, show that $\overrightarrow{AE} = \frac{\mathbf{a} + 2\mathbf{b}}{4}$.
 Explain why $\overrightarrow{AF} = \alpha\overrightarrow{AE}$ and $\overrightarrow{CF} = \beta\overrightarrow{CB}$, where $\alpha, \beta \in \mathbb{R}$.
 Considering the triangle ACF , show that $(\alpha - 4\beta)\mathbf{a} + 2(\alpha + 2\beta - 2)\mathbf{b} = \mathbf{0}$.
Hence, find the values of α and β .

(b) Let ABC be an equilateral triangle of sides $2a$ and let D, E, F be the mid points of AB, BC and AC respectively. Forces of magnitudes $2P, \sqrt{3}P, 2\sqrt{3}P$ and αP act respectively along $\overrightarrow{AB}, \overrightarrow{AE}, \overrightarrow{DC}$ and \overrightarrow{BC} . It is given that the resultant of this system of forces is acting parallel to \overrightarrow{AC} . Find the value of α .
 The system of forces is equivalent to a single force of magnitude R acting through A together with a couple of magnitude G . Find the values of R and G .
 Write down the magnitude and the direction of the resultant of this system of forces and find the distance from A to the point at which the line of action of the resultant meets AB .
 A couple of magnitude H is now added to the system. The resultant of this new system acts through the point B . Find the value of H and the sense of this couple.

(a)

$\underline{a}, \underline{b} \neq \underline{0}$ and $\underline{a} \nparallel \underline{b}$

$\lambda\underline{a} + \mu\underline{b} = \underline{0}$ _____ (1)

If $\lambda \neq 0$, then $\underline{a} = -\frac{\mu}{\lambda}\underline{b}$. (5)

This contradicts the given condition.

$\therefore \lambda = 0$. (5)

Now, (1) gives us $\mu\underline{b} = \underline{0}$

Since $\underline{b} \neq \underline{0}$, we have $\mu = 0$ (5)

$\therefore \lambda = 0$ and $\mu = 0$

15

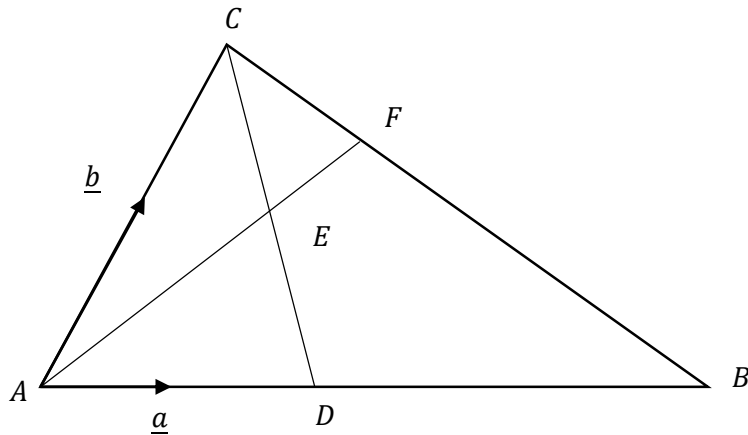

$$\begin{aligned} \vec{AE} &= \vec{AD} + \vec{DE} && \textcircled{5} \\ &= \vec{AD} + \frac{1}{2}\vec{DC} && \textcircled{5} \\ &= \frac{1}{2}\underline{a} + \frac{1}{2}(\vec{DA} + \vec{AC}) && \textcircled{5} \\ &= \frac{1}{2}\underline{a} + \frac{1}{2}\left(-\frac{1}{2}\underline{a} + \underline{b}\right) \\ &= \frac{\underline{a} + 2\underline{b}}{4}. && \textcircled{5} \end{aligned}$$

20

$$\begin{aligned} AF \parallel AE \text{ (or } A, E, F \text{ are collinear)} &&& \textcircled{5} \\ CF \parallel CB \text{ (or } C, F, B \text{ are collinear)} &&& \textcircled{5} \end{aligned}$$

10

$$\begin{aligned} \vec{AF} &= \vec{AC} + \vec{CF} && \textcircled{5} \\ \therefore \alpha\vec{AE} &= \underline{b} + \beta\vec{CB} \\ \therefore \alpha\left(\frac{\underline{a} + 2\underline{b}}{4}\right) &= \underline{b} + \beta(\vec{CA} + \vec{AB}) && \textcircled{5} \end{aligned}$$

PAPERMASTER.LK

$$\therefore \alpha \underline{a} + 2\alpha \underline{b} = 4\underline{b} + 4\beta(-\underline{b} + \underline{a})$$

$$\therefore (\alpha - 4\beta)\underline{a} + (2\alpha + 4\beta - 4)\underline{b} = \underline{0} \quad (5)$$

$\underline{a}, \underline{b} \neq 0$ and $\underline{a} \nparallel \underline{b}$ give us,

$$\alpha - 4\beta = 0 \text{ or } 2\alpha + 4\beta - 4 = 0$$

$$\therefore \alpha = \frac{4}{3} \text{ and } \beta = \frac{1}{3}$$

(5)

(5)

25

(b)

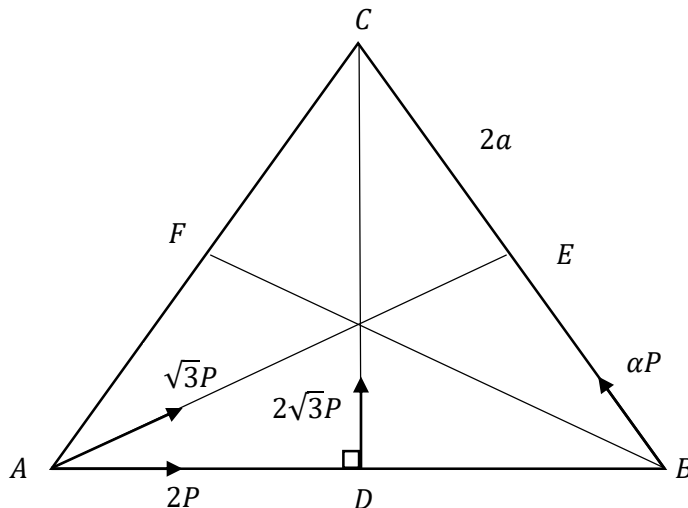

$$\rightarrow X = 2P + \sqrt{3}P \cos \frac{\pi}{6} - \alpha P \cos \frac{\pi}{3} \quad (5)$$

$$= 2P + \frac{3P}{2} - \frac{\alpha P}{2}$$

$$= \frac{1}{2}(7 - \alpha)P$$

$$\uparrow Y = \sqrt{3}P \sin \frac{\pi}{6} + 2\sqrt{3}P + \alpha P \sin \frac{\pi}{3} \quad (5)$$

$$= \frac{\sqrt{3}}{2}P + 2\sqrt{3}P + \frac{\sqrt{3}}{2}\alpha P$$

$$= \frac{\sqrt{3}}{2}(5 + \alpha)P$$

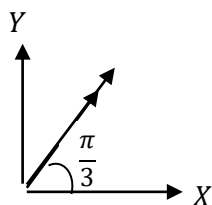

$$\tan \frac{\pi}{3} = \frac{Y}{X} \quad (5)$$

$$\therefore Y = \sqrt{3}X$$

$$\text{i.e. } \frac{\sqrt{3}}{2}(5 + \alpha)P = \sqrt{3} \cdot \frac{1}{2}(7 - \alpha)P$$

$$\therefore \alpha = 1 \quad (5)$$

20

OR

10

$$\alpha P \left(\frac{\sqrt{3}}{2} \right) + 2\sqrt{3}P \left(\frac{1}{2} \right) - \sqrt{3}P \left(\frac{1}{2} \right) - 2P \left(\frac{\sqrt{3}}{2} \right) = 0. \quad (5)$$

$$\Rightarrow \alpha = 1 + 2 - 2.$$

$$\Rightarrow \alpha = 1. \quad (5)$$

20

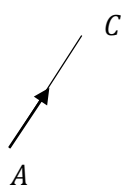

$$R = \sqrt{3}P \left(\frac{\sqrt{3}}{2} \right) + 2P \left(\frac{1}{2} \right) + 2\sqrt{3}P \left(\frac{\sqrt{3}}{2} \right) + P \left(\frac{1}{2} \right) \quad (10)$$

$$= \frac{3P}{2} + \frac{2P}{2} + \frac{6P}{2} + \frac{P}{2}$$

$$= 6P.$$

(5)

$$\overset{\curvearrowleft}{A}; G = 2\sqrt{3}P \cdot a + P \left(\frac{\sqrt{3}}{2} \right) \cdot 2a \quad (5)$$

$$G = 2\sqrt{3}Pa \left(1 + \frac{1}{2} \right)$$

$$G = 3\sqrt{3}Pa \quad (5)$$

25

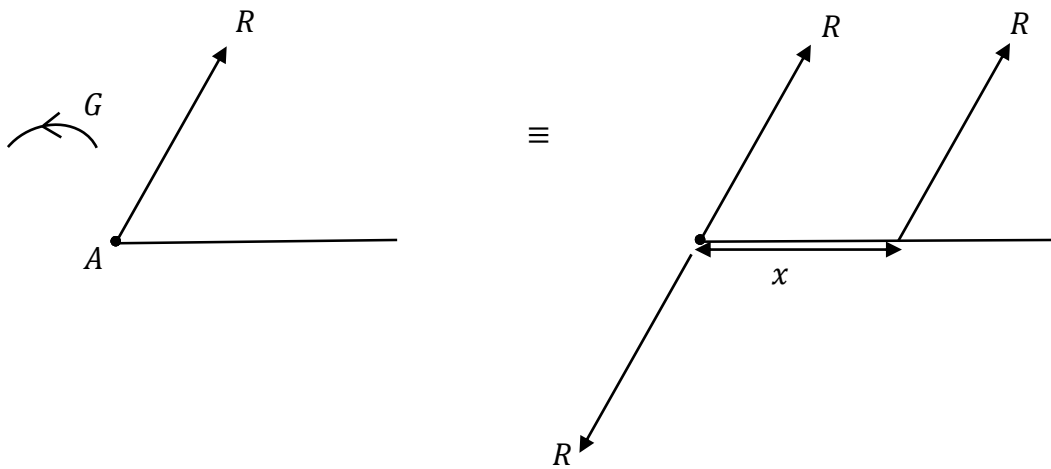

Magnitude of the resultant = $R = 6P$ (5)

Direction:

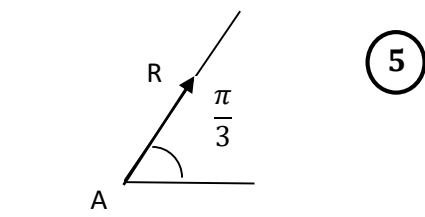

$A; 3\sqrt{3}Pa = 6P \left(\frac{\sqrt{3}}{2}\right)x$ (5)

$\therefore x = a$ (5)

20

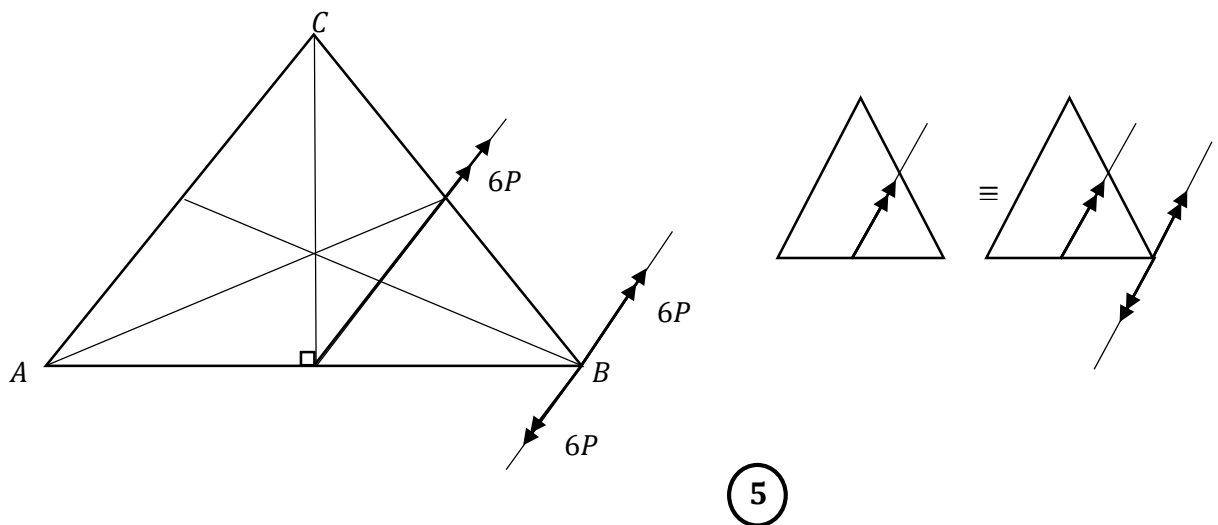

(5)

$$\curvearrowleft H = 6P \cdot a \left(\frac{\sqrt{3}}{2} \right)$$

$$= 3\sqrt{3}Pa \quad (5)$$

Contra-clockwise sense

$$\curvearrowleft (5)$$

15

15.(a) Two uniform rods AB and BC , each of length $2a$, are smoothly joined at the end B . The weights of the rods AB and BC are W and $2W$, respectively. The end A is smoothly hinged to a fixed point on a horizontal floor. A particle of weight W is attached to the point D on rod AB such that $AD = \frac{a}{2}$. The system is in equilibrium in a vertical plane such that $\widehat{BAC} = \theta$ and the end-point C of the rod BC on a rough portion of the above horizontal floor, as shown in the figure. The coefficient of friction between the rod BC and the floor is μ . Show that $\cot \theta \leq \frac{15}{7}\mu$. Find the reaction exerted on AB by CB at the joint B .

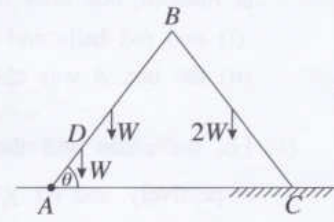

(b) The framework shown in the figure consists of five light rods AB , BC , CD , DA and DB of equal lengths smoothly joined at their ends. A load W is suspended at the joint D and the framework is smoothly hinged at A to a fixed point and kept in equilibrium in a vertical plane with BD vertical by a force P applied to it at the joint C and perpendicular to the rod CD , in the direction shown in the figure.

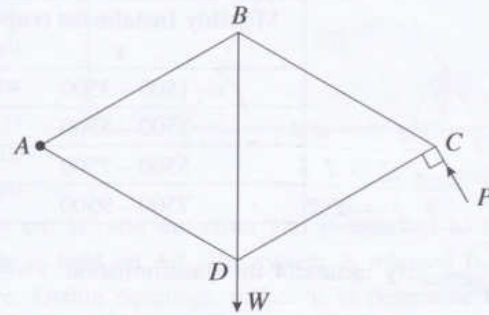

(i) Find the value of P .

(ii) Draw a stress diagram using Bow's notation for the joints C , B and D .

Hence, find the stresses in the rods, stating whether they are tensions or thrusts.

(a)

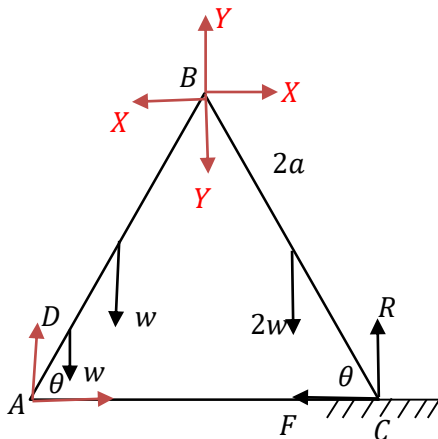

For the system;



$$R \cdot 4a \cos \theta - w \left(\frac{a}{2} \cos \theta + a \cos \theta \right) - 2w(2a \cos \theta + a \cos \theta) = 0 \quad (15)$$

$$\therefore 4R = \frac{3}{2}w + 6w$$

$$R = \frac{15}{8}w.$$

For BC :

$$B \curvearrowright 2wa \cos \theta + F2a \sin \theta - R \cdot 2a \cos \theta = 0 \quad (10)$$

$$\therefore w + F \tan \theta = R$$

$$\therefore F \tan \theta = \frac{15}{8}w - w.$$

$$\therefore F = \frac{7}{8}w \cot \theta. \quad (5)$$

For the Equilibrium,

$$\mu \geq \frac{F}{R}.$$

$$\frac{7}{8}w \cot \theta \leq \mu \frac{15}{8}w$$

$$\cot \theta \leq \frac{15}{7}\mu. \quad (5)$$

45

$$\leftarrow BC: \quad X = F = \frac{7}{8}w \cot \theta \quad (5)$$

$$\uparrow R + Y = 2w \quad (5)$$

$$Y = 2w - R$$

$$= 2w - \frac{15}{8}w$$

$$= \frac{w}{8} \quad (5)$$

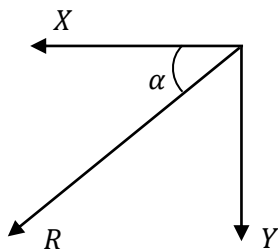

$$R^2 = X^2 + Y^2$$

$$= \frac{49}{64}w^2 \cot^2 \theta + \frac{w^2}{64}$$

$$R = \frac{w}{8} \sqrt{1 + 49 \cot^2 \theta} \quad (5)$$

$$\tan \alpha = \frac{Y}{X} = \frac{w/8}{7w/8 \cot \theta} = \frac{\tan \theta}{7}$$

$$\alpha = \tan^{-1} \left(\frac{\tan \theta}{7} \right) \quad (5)$$

20

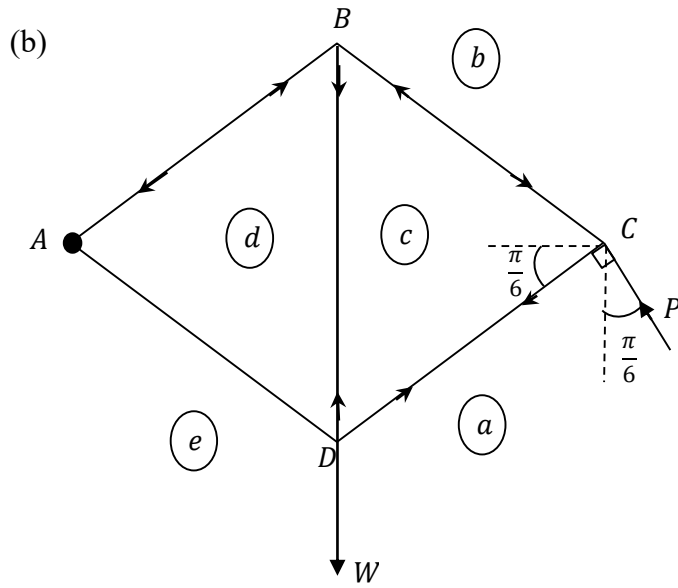

$$\sum \tau_A = 0 \quad P \cos \frac{\pi}{6} \cdot 2x - Wx = 0 \quad (5)$$

(Here $AC = 2x$)

$$\therefore P = \frac{W}{\sqrt{3}} \quad (5)$$

10

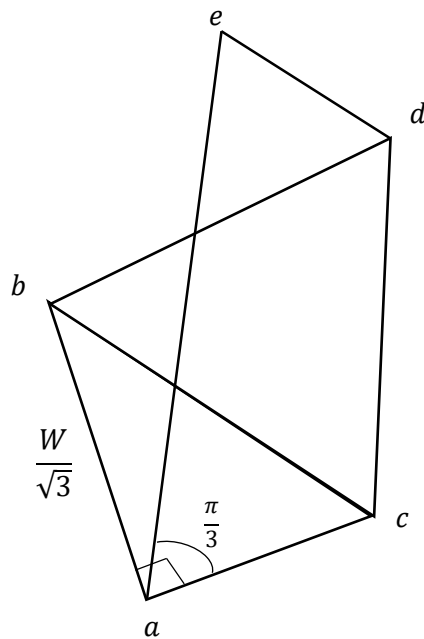

$$(10) + (10) + (10)$$

Each Joint (10)

30

Rod	Tension	Thrust
AB		$\frac{2W}{3}$
BC		$\frac{2W}{3}$
CD	$\frac{W}{3}$	
DA	$\frac{W}{3}$	
BD	$\frac{2W}{3}$	

magnitude - (5) each

Tension/Thrust (15)

All 5 correct (15)

4 correct (10)

3 correct (5)

50

16. Show that the centre of mass of

- (i) a thin uniform wire in the shape of a semi-circular arc of radius a , is at a distance $\frac{2a}{\pi}$ from its centre,
- (ii) a uniform hollow right circular cone of height h is at a distance $\frac{1}{3}h$ from the centre of the base of the cone.

A bucket is made by rigidly fixing to a uniform thin shell in the shape of a frustum of hollow right circular cone of radii of the upper and lower circular rims $2a$ and a , respectively and height $\frac{4a}{3}$ the following parts at the places each meets this shell as shown in the figure:

- A uniform thin circular plate of radius a and centre at O .
- A uniform thin shell in the shape of a hollow right circular cylinder of radius a and height $\frac{2a}{3}$.
- A uniform thin wire in the shape of a semi-circle of radius $2a$ and centre at C .

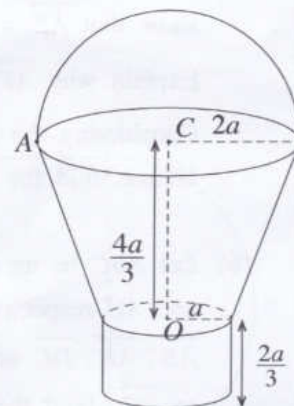

The mass per unit area of the frustum, plate and the cylinder is σ and the mass per unit length of the wire is $11a\sigma$.

Show that the distance from O to the centre of mass of the bucket is $(10\pi + 27)\frac{a}{9\pi}$.

Find the angle OC makes with the downward vertical in the equilibrium position, when the bucket is hung freely by a vertical string from the point A at which the wire meets the upper rim of the frustum.

(i)

Semi-circular wire

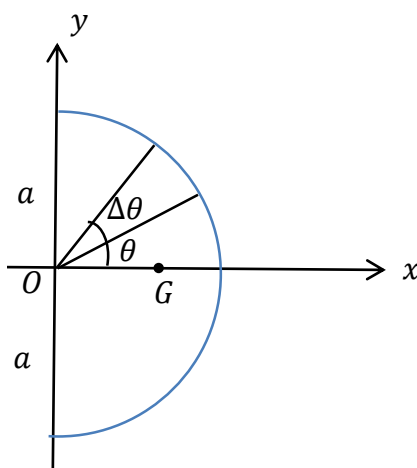

By Symmetry, centre of mass G lies on x -axis. 5

$\Delta m = a\Delta\theta\rho$, where ρ is the mass per unit length.

Let $OG = \bar{x}$.

PAPERMASTER.LK

Then

$$\bar{x} = \frac{\int_{-\pi/2}^{\pi/2} a\rho \cos \theta d\theta}{\int_{-\pi/2}^{\pi/2} a\rho d\theta} = \frac{a \sin \theta \Big|_{-\pi/2}^{\pi/2}}{\theta \Big|_{-\pi/2}^{\pi/2}} = \frac{2a}{\pi}$$

30

(ii)

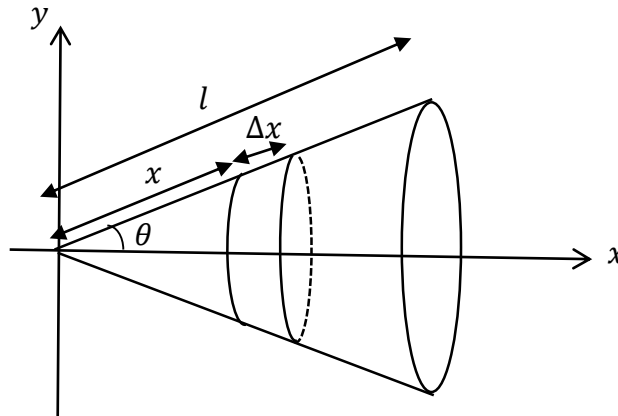

By Symmetry, centre of mass G lies on x -axis. (5)

$$h = l \cos \theta$$





$\Delta m = 2\pi(x \sin \theta)\Delta x\sigma$, where σ is the mass per unit length.

$$\therefore \bar{x} = \frac{\int_0^l x \cos \theta 2\pi\sigma x \sin \theta dx}{\int_0^l 2\pi\sigma x \sin \theta dx} = \frac{\cos \theta \int_0^l x^2 dx}{\int_0^l x dx} = \frac{h/2 \frac{x^3}{3} \Big|_0^l}{\frac{x^2}{2} \Big|_0^l} = \frac{2h}{3}$$

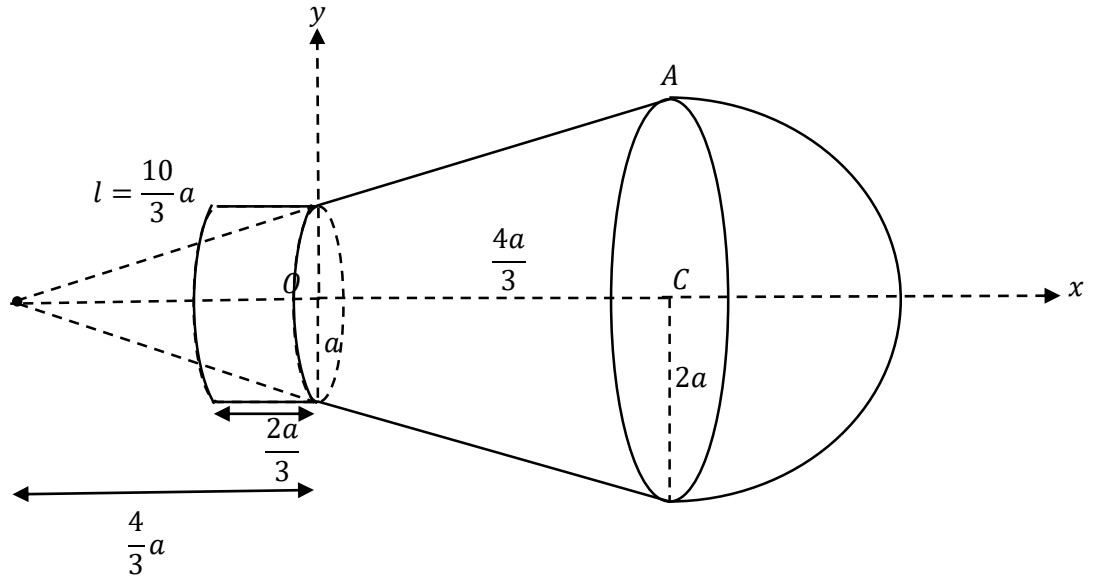
\therefore The required distance = $\frac{h}{3}$.

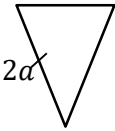
30

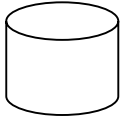

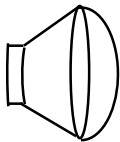
Object	Mass	Distance from $O(\uparrow)$	
	$\pi(2a)(11a\sigma)$ $= 22\pi a^2\sigma \quad (5)$	$\frac{4}{3}a + 2\frac{(2a)}{\pi} = \frac{4}{3}a + \frac{4a}{\pi}$	(5)
	$\pi(2a)\left(\frac{10}{3}a\right)\sigma$ $= \frac{20}{3}\pi a^2\sigma \quad (5)$	$\left[\frac{2}{3}\left(\frac{8}{3}a\right) - \frac{4}{3}a\right] = \frac{4}{9}a$	(5)
	$\pi(a)\left(\frac{5}{3}a\right)\sigma$ $= \frac{5}{3}\pi a^2\sigma \quad (5)$	$-\frac{1}{3}\left(\frac{4}{3}a\right) = -\frac{4}{9}a$	(5)
	$2\pi a\left(\frac{2}{3}a\right)\sigma$ $= \frac{4}{3}\pi a^2\sigma \quad (5)$	$-\frac{1}{3}a$	(5)
	$\pi a^2\sigma$	0	(5)
	$22\pi a^2\sigma + \frac{20}{3}\pi a^2\sigma + \frac{5}{3}\pi a^2\sigma$ $+ \frac{4}{3}\pi a^2\sigma$ $= \frac{88}{3}\pi a^2\sigma \quad (5)$	\bar{x}	

By symmetry, centre of mass lies on the x -axis. (5)

$$\frac{88}{3}\pi a^2\sigma \bar{x} = 22\pi a^2\sigma \left(\frac{4}{3}a + \frac{4a}{\pi}\right) + \frac{20}{3}\pi a^2\sigma \left(\frac{4}{9}a\right) - \frac{5}{3}\pi a^2\sigma \left(-\frac{4}{9}a\right) + \frac{4}{3}\pi a^2\sigma \left(-\frac{1}{3}a\right)$$

$$\frac{88}{3}\bar{x} = 4a \left(\frac{22}{3} + \frac{22}{\pi} + \frac{20}{27} + \frac{5}{27} - \frac{1}{9} \right) \quad (15)$$

$$\underbrace{\frac{22}{27} + \frac{5}{27}}_{\frac{22}{27}}$$

$$\frac{88}{3}\bar{x} = 22 \times 4a \left(\frac{10}{27} + \frac{22}{\pi} \right)$$

PAPERMASTER.LK

$$\frac{88}{3}\bar{x} = 88a\left(\frac{(10\pi + 27)}{27\pi}\right)$$

$$\bar{x} = \frac{a}{9\pi}(10\pi + 27) \quad (5)$$

75

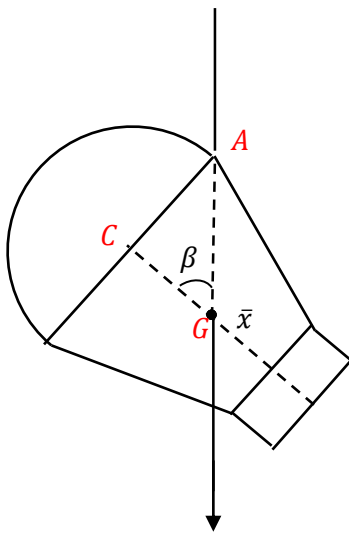

$$\begin{aligned} \tan \beta &= \frac{AC}{CG} = \frac{2a}{\frac{4}{3}a - \bar{x}} \quad (5) \\ &= \frac{18\pi}{27 - 2\pi} \quad (5) \\ \therefore \beta &= \tan^{-1}\left(\frac{18\pi}{27 - 2\pi}\right) \end{aligned}$$

15

- 17.(a) Two identical boxes A and B, each contains 10 balls which are identical in all respects except for their colour. The box A contains 6 white balls and 4 red balls, and the box B contains 8 white balls and 2 red balls. A box is chosen at random and 3 balls are drawn from that box at random, one after the other, without replacement. Find the probability that
- (i) two red balls and one white ball are drawn,
 - (ii) the box A was chosen, given that two red balls and one white ball are drawn.

- (b) Let the mean and the standard deviation of the set of data $\{x_1, x_2, \dots, x_n\}$ be \bar{x} and σ_x respectively, and let $y_i = \frac{x_i - \alpha}{\beta}$ for $i = 1, 2, \dots, n$ where α and β (>0) are real constants. Show that $\bar{y} = \frac{\bar{x} - \alpha}{\beta}$ and $\sigma_y = \frac{\sigma_x}{\beta}$, where \bar{y} and σ_y are respectively the mean and the standard deviation of the set of data $\{y_1, y_2, \dots, y_n\}$.

Monthly instalments for an insurance scheme by 100 employees of a company are given in the following frequency table:

Monthly Instalment (rupees) x	Number of employees
1500 – 3500	30
3500 – 5500	40
5500 – 7500	20
7500 – 9500	10

By means of the transformation $y = \frac{x - 500}{1000}$, estimate the mean and the standard deviation of y , and also the coefficient of skewness of y defined by $\frac{3(\text{mean} - \text{median})}{\text{standard deviation}}$.

Hence, estimate the mean, the standard deviation and the coefficient of skewness of x .

(a)

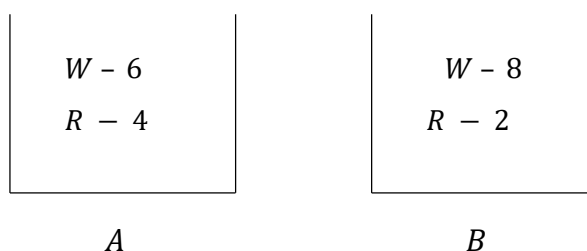

Let X be the event that two red balls and one white ball are drawn.

(i) $P(X) = P(X|A)P(A) + P(X|B)P(B)$ _____ (1)

5

$P(A) = P(B) = \frac{1}{2}$ 5

PAPERMASTER.LK

$$\begin{aligned}
 P(X|A) &= \frac{4}{10} \times \frac{3}{9} \times \frac{6}{8} + \frac{4}{10} \times \frac{6}{9} \times \frac{3}{8} + \frac{6}{10} \times \frac{4}{9} \times \frac{3}{8} \\
 &= \frac{3}{10} \cdot \textcircled{5}
 \end{aligned}$$

$$\begin{aligned}
 P(X|B) &= \frac{2}{10} \times \frac{1}{9} \times \frac{8}{8} + \frac{2}{10} \times \frac{8}{9} \times \frac{1}{8} + \frac{8}{10} \times \frac{2}{9} \times \frac{1}{8} \\
 &= \frac{1}{15} \cdot \textcircled{5}
 \end{aligned}$$

Now (1) given as,

$$P(X) = \frac{3}{10} \times \frac{1}{2} + \frac{1}{15} \times \frac{1}{2} = \frac{11}{60} \textcircled{5}$$

55

(ii)

$$P(A|X) = \frac{P(X|A)P(A)}{P(X)} \textcircled{5} \quad [\text{or Bayes' theorem}]$$

$$= \frac{\frac{3}{10} \times \frac{1}{2}}{\frac{11}{60}}$$

$$= \frac{9}{11} \textcircled{5}$$

10

(b)

$$\bar{y} = \frac{\sum_{i=1}^n y_i}{n} \quad (5)$$

$$y_i = \frac{x_i - \alpha}{\beta}$$

$$= \frac{1}{n\beta} \sum_{i=1}^n (x_i - \alpha)$$

$$= \frac{1}{n\beta} \left\{ \sum_{i=1}^n x_i - n\alpha \right\}$$

$$= \frac{1}{\beta} \left\{ \frac{\sum_{i=1}^n x_i}{n} - \alpha \right\}$$

$$= \frac{\bar{x} - \alpha}{\beta} \quad (5)$$

$$\sigma_y^2 = \frac{\sum_{i=1}^n (y_i - \bar{y})^2}{n} \quad (5)$$

$$= \frac{1}{n} \sum_{i=1}^n \left(\frac{x_i - \alpha}{\beta} - \frac{\bar{x} - \alpha}{\beta} \right)^2$$

$$= \frac{1}{n\beta^2} \sum_{i=1}^n (x_i - \bar{x})^2$$

$$= \frac{\sigma_x^2}{\beta^2}$$

$$\therefore \sigma_y = \frac{\sigma_x}{\beta} \quad (5) \quad (\because$$

20

Class Interval x	f	Class Interval y	Mid-point y	fy	fy^2
1500-3500	30	1-3	2	60	120
3500-5500	40	3-5	4	160	640
5500-7500	20	5-7	6	120	720
7500-9500	10	7-9	8	80	640
				$\sum fy = 420$	$\sum fy^2 = 2120$

$$\bar{y} = \frac{\sum fy}{\sum f} = \frac{420}{100} = 4.2 \quad (5)$$

$$\begin{aligned} \sigma_y &= \sqrt{\frac{\sum fy^2}{\sum f} - \bar{y}^2} = \sqrt{\frac{2120}{100} - 4.2^2} \\ &= \sqrt{21.2 - 17.64} \\ &= \sqrt{3.56} \approx 1.887 \end{aligned} \quad (5)$$

Let $M_y =$ Median of $y = 50^{\text{th}}$ data

Then

$$M_y = 3 + \frac{(50 - 30)}{40}(5 - 3) = 4 \quad (5)$$

$$\therefore \text{The coefficient of skewness: } y \approx \frac{3(4.2 - 4)}{\sqrt{3.56}} \approx 0.317$$

$$\begin{aligned}\bar{x} &= 1000\bar{y} + 500 \\ &= 1000 \times 4.2 + 500 \\ &= 4700 \quad (5)\end{aligned}$$

$$\begin{aligned}\sigma_x &= 1000 \sigma_y \\ &\approx 1000 \times 1.887 \\ &= 1887 \quad (5)\end{aligned}$$

The coefficient of skewness does not change.

$$S_x = S_y \approx 0.317 \quad (5)$$

15