



Department of Examinations - Sri Lanka

G.C.E. (A/L) Examination - 2022 (2023)

10 - Combined Mathematics I

Marking Scheme

PAPERMASTER.LK

This document has been prepared for the use of Marking Examiners. Some changes would be made according to the views presented at the Chief Examiners' meeting.

Amendments to be included

1. Using the Principle of Mathematical Induction, prove that $\sum_{r=1}^n \frac{1}{r(r+1)} = \frac{n}{n+1}$ for all $n \in \mathbb{Z}^+$.

For $n=1$, L.H.S. = $\frac{1}{2}$ and R.H.S. = $\frac{1}{2}$. (5)

∴ The result is true for $n=1$. (5)

Take any $k \in \mathbb{Z}^+$ and assume that the result is true for $n=k$.

i.e. $\sum_{r=1}^k \frac{1}{r(r+1)} = \frac{k}{k+1}$ (1) (5)

Now, $\sum_{r=1}^{k+1} \frac{1}{r(r+1)} = \sum_{r=1}^k \frac{1}{r(r+1)} + \frac{1}{(k+1)(k+2)}$

$= \frac{k}{k+1} + \frac{1}{(k+1)(k+2)}$ (5)

$= \frac{k(k+2)+1}{(k+1)(k+2)}$

$= \frac{(k+1)^2}{(k+1)(k+2)}$

$= \frac{k+1}{k+2}$. (5)

Hence, if the result is true for $n=k$, it is also true for $n=k+1$. We have already proved that the result is true for $n=1$.

Hence, by the Principle of Mathematical Induction, the result is true for all $n \in \mathbb{Z}^+$. (5)

2. Sketch the graphs of $y = 2 - |x - 2|$ and $y = ||x| - 2|$ in the same diagram.

Hence or otherwise, find all real values of x satisfying the inequality $||x| - 2| + |x - 2| \leq 2$.

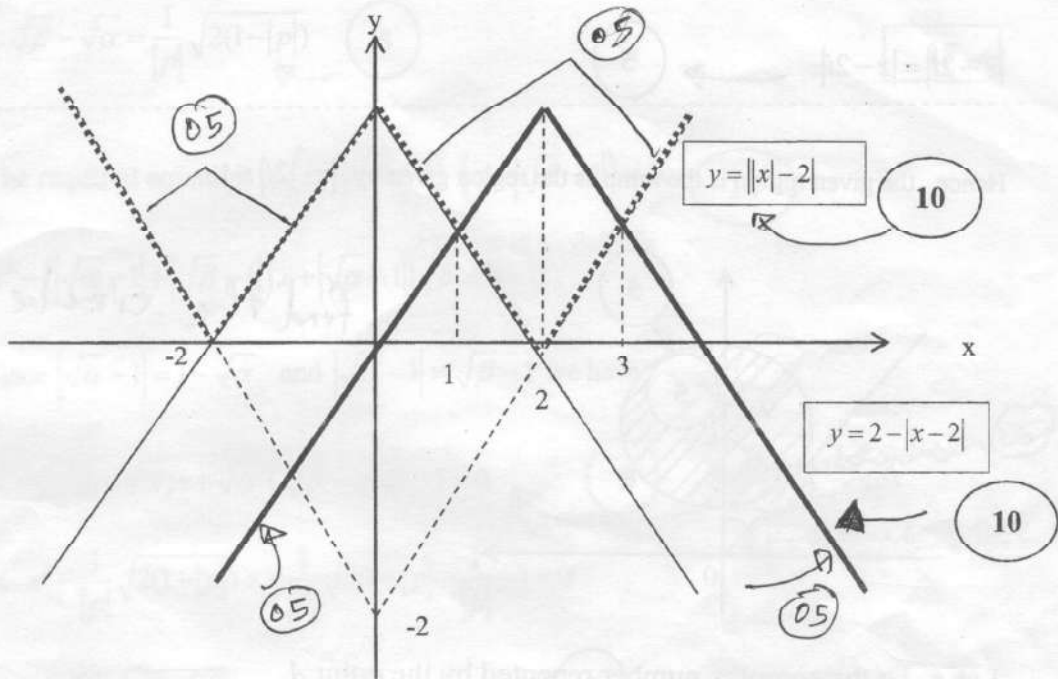

$$||x| - 2| + |x - 2| \leq 2$$

$$\Leftrightarrow ||x| - 2| \leq 2 - |x - 2|$$

From the graph, we have $1 \leq x \leq 3$. 5

1, 3 find for 05 marks.

3. Shade in an Argand diagram, the region consisting of points that represent the complex numbers z satisfying the inequality $|\bar{z} + 2i| \leq 1$.
Find the greatest value of $\text{Arg } z$ for the complex numbers z represented by the points in this shaded region.

$$|\bar{z} + 2i| = |z - 2i| \quad \rightarrow \quad (5)$$

Hence, the given region is the same as the region given by $|z - 2i| \leq 1$.

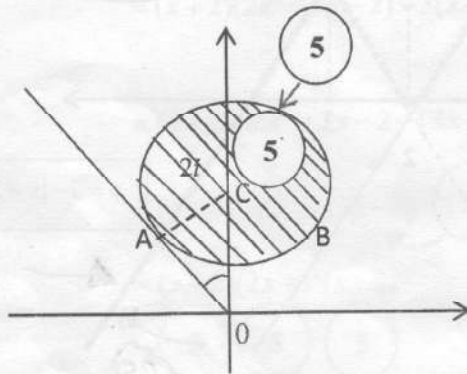

find the circle - (05)

Let z_0 be the complex number represented by the point A.

From the $\triangle OAC$, we have $\angle AOC = \frac{\pi}{6}$. (5)

The required greatest value of $\text{Arg } z = \text{Arg } z_0$

$$\begin{aligned} &= \frac{\pi}{2} + \frac{\pi}{6} \\ &= \frac{2\pi}{3} \end{aligned} \quad (5)$$

Direct solve (10) marks

Aliter for the first (5) :

Let $z = x + iy$, where $x, y \in \mathbb{R}$

$$\begin{aligned} \text{Then } |\bar{z} + 2i|^2 &= |x - (y - z)i|^2 \\ &= x^2 + (y - 2)^2 \end{aligned} \quad (5)$$

Hence, the given region is the same as the region given by $x^2 + (y - 2)^2 \leq 1$.

4. Let $a \in \mathbb{R}$. Write down the expansion of $(2+ax)^5$ in ascending powers of x up to and including x^2 term. Hence, find the values of a for which the coefficient of x^2 in the expansion of $(4-5x)(2+ax)^5$ is -80 .

The required expansion = ${}^5C_0 2^5 + {}^5C_1 2^4(ax) + {}^5C_2 2^3(ax)^2$ (5) ← In

= $32 + 5 \times 16ax + 10 \times 8a^2x^2$ (5)

= $32 + 80ax + 80a^2x^2$ ←

Direct gives (10) marks

Now, $(4-5x)(2+ax)^5 = 4(2+ax)^5 - 5x(2+ax)^5$

The coefficient of $x^2 = 4 \times 80a^2 - 5 \times 80a$ (5)

It is given that $4 \times 80a^2 - 5 \times 80a = -80$ ← (5)

$\therefore 4a^2 - 5a + 1 = 0$. ← Direct gives (10) Marks

$\therefore (4a-1)(a-1) = 0$.

$\therefore a = \frac{1}{4}$ or $a = 1$. (5)

5. Show that $\lim_{x \rightarrow 0} \frac{x((1+x)\operatorname{cosec} 2x - \cot 2x)}{\sqrt{1+2x} - \sqrt{1-2x}} = \frac{1}{4}$.

$$\begin{aligned} & \lim_{x \rightarrow 0} \frac{x((1+x)\operatorname{cosec} 2x - \cot 2x)}{\sqrt{1+2x} - \sqrt{1-2x}} \\ &= \lim_{x \rightarrow 0} \frac{x}{\sin 2x} \cdot \frac{(1+x - \cos 2x)}{(\sqrt{1+2x} - \sqrt{1-2x})} \quad (5) \\ &= \lim_{x \rightarrow 0} \frac{x}{\sin 2x} \cdot \frac{(1+x - \cos 2x)}{(\sqrt{1+2x} - \sqrt{1-2x})} \times \frac{(\sqrt{1+2x} + \sqrt{1-2x})}{(\sqrt{1+2x} + \sqrt{1-2x})} \quad (5) \\ &= \lim_{x \rightarrow 0} \frac{1}{2} \cdot \frac{2x}{\sin 2x} \cdot \frac{(2\sin^2 x + x)}{[(1+2x) - (1-2x)]} \cdot (\sqrt{1+2x} + \sqrt{1-2x}) \\ &= \lim_{x \rightarrow 0} \frac{1}{2} \cdot \frac{2x}{\sin 2x} \cdot \left(\frac{2\sin^2 x}{4x} + \frac{1}{4} \right) (\sqrt{1+2x} + \sqrt{1-2x}) \quad (5) \\ &= \frac{1}{2} \times 1 \times \frac{1}{4} \times 2 \quad (10) \\ &= \frac{1}{4} \end{aligned}$$

conjugate gives (8)

bank $\frac{1}{2}$ ← gives (5)

All three limits correct	(10)
Any two	(5)

6. Using $\frac{d}{dx} \{x(x^2+1) \tan^{-1} x\} = (3x^2+1) \tan^{-1} x + x$, show that $\int_0^1 (3x^2+1) \tan^{-1} x \, dx = \frac{1}{2}(\pi-1)$.

The region enclosed by the curves $y = \sqrt{2(3x^2+1) \tan^{-1} x}$, $x=1$ and $y=0$ is rotated about the x-axis through 2π radians. Show that the volume of the solid thus generated is $\pi(\pi-1)$.

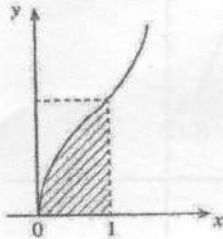

Using $\frac{d}{dx} \{x(x^2+1) \tan^{-1} x\} = (3x^2+1) \tan^{-1} x + x$,

we have

$$\int_0^1 [(3x^2+1) \tan^{-1} x + x] \, dx = x(x^2+1) \tan^{-1} x \Big|_0^1 \quad (5)$$

$$\therefore \int_0^1 (3x^2+1) \tan^{-1} x \, dx + \int_0^1 x \, dx = 2 \tan^{-1} 1$$

$$\therefore \int_0^1 (3x^2+1) \tan^{-1} x \, dx + \frac{x^2}{2} \Big|_0^1 = 2 \frac{\pi}{4} \quad (5)$$

$$\therefore \int_0^1 (3x^2+1) \tan^{-1} x \, dx = \left(\frac{\pi}{2} - \frac{1}{2} \right)$$

$$= \frac{1}{2}(\pi-1) \quad (5)$$

The required volume = $\pi \int_0^1 2(3x^2+1) \tan^{-1} x \, dx \quad (5)$

$$= 2\pi \frac{1}{2}(\pi-1) \quad (5)$$

$$= \pi(\pi-1).$$

No limit gives 05

No limit gives 05

7. Let $a, b > 0$. A curve is parametrically given by $x = a \sec \theta$ and $y = b \tan \theta$ for $0 < \theta < \frac{\pi}{2}$. The tangent line to the curve at the point $P \equiv (a \sec \theta, b \tan \theta)$ passes through the point $(0, -b)$. Find the coordinates of P .

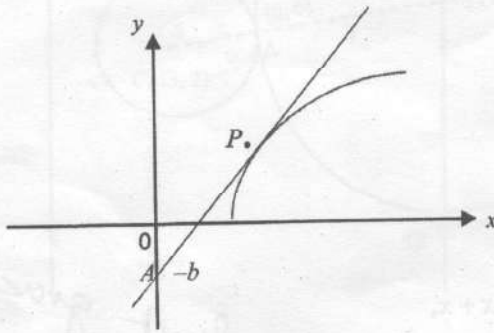

$$x = a \sec \theta, \quad y = b \tan \theta$$

$$\frac{dx}{d\theta} = a \sec \theta \tan \theta, \quad \frac{dy}{d\theta} = b \sec^2 \theta \quad (5)$$

If both correct

$$\therefore \frac{dy}{dx} = \frac{b \sec^2 \theta}{a \sec \theta \tan \theta} \quad (5)$$

$$\therefore = \frac{b \sec \theta}{a \tan \theta} \quad (10) \quad \text{If correct gives } (10) \text{ marks}$$

The gradient of $AP = \frac{b + b \tan \theta}{a \sec \theta}$.

From the given condition, we have $\frac{b \sec \theta}{a \tan \theta} = \frac{b(1 + \tan \theta)}{a \sec \theta} \quad (5)$

$$\begin{aligned} \therefore \sec^2 \theta &= \tan \theta + \tan^2 \theta \quad (5) \\ \therefore \tan \theta &= 1 \quad \text{If correct gives } (5) \\ \therefore \theta &= \frac{\pi}{4} \\ \therefore P &\equiv (\sqrt{2}a, b) \quad (5) \end{aligned}$$

8. Let $ABCD$ be a square with $A \equiv (1, 3)$ and $C \equiv (7, 5)$. Find the x -coordinates of B and D .

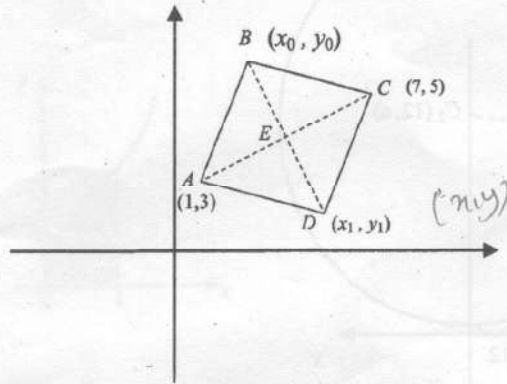

$E \equiv (4, 4)$
 $\frac{y-4}{x-4} = -3$
 $y-4 = -3(x-4)$
 $y = -3x + 16$
 $x = 4 + t$
 $y = -3t + 16$
 $AE = DE$
 $\sqrt{(x-4)^2 + (y-4)^2} = \sqrt{(x-4)^2 + (y-4)^2}$
 $|t| = 1$
 $t = \pm 1$
 $B \equiv (5, 13)$
 $D \equiv (3, 13)$

Let $B = (x_0, y_0)$ and $D = (x_1, y_1)$

Since E is the mid-point of AC , we have $E \equiv (4, 4)$. (5)

Then, $AE^2 = 3^2 + 1^2 = 10$

Since $ABCD$ is a square, we have $BE = AE$.

Hence, $(x_0 - 4)^2 + (y_0 - 4)^2 = 10$. ----- (1) (5)

Also, $AE \perp BE$.

$\therefore \left(\frac{4-3}{4-1}\right) \times \left(\frac{y_0-4}{x_0-4}\right) = -1$. (5)

Hence, $y_0 - 4 = -3(x_0 - 4)$ ----- (2)

(1) and (2) $\Rightarrow (x_0 - 4)^2 + 9(x_0 - 4)^2 = 10$. (5)

Hence, $y_0 - 4 = -3(x_0 - 4)$.

$\therefore (x_0 - 4)^2 = 1$.

$\therefore (x_0 - 4) = \pm 1$.

$\therefore x_0 = 5$ or $x_0 = 3$. (5)

Note that (x_1, y_1) also satisfies (1) and (2), when (x_0, y_0) is replaced by (x_1, y_1) .

Hence, x coordinates of B and D are 3 and 5.

PAPERMASTER.LK

9. Find the equation of the circle that touches the circle $x^2 + y^2 - 6x - 4y - 12 = 0$ externally at the point $(6, 6)$ and has its centre on the line $x = 12$.

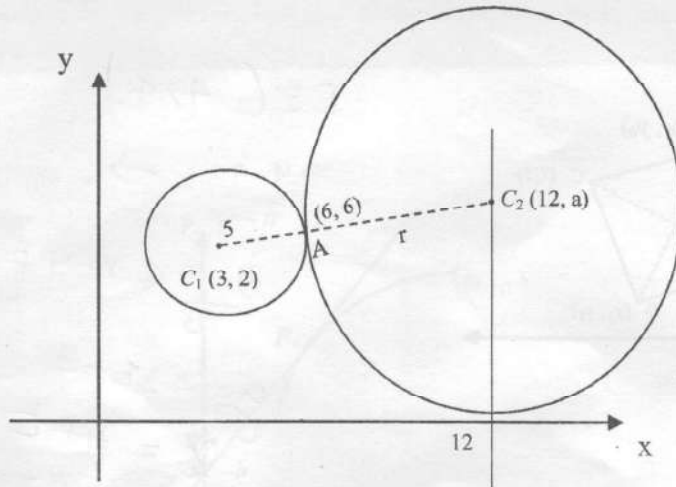

Let the center of the given circle be C_1 and the center of the required circle be C_2

Then $C_1 \equiv (3, 2)$ and $C_2 \equiv (12, a)$; where $a \in \mathbb{R}$ (5)

Since the circles touch externally C_2 lies on the line C_1A .

$$\therefore \frac{6-2}{6-3} = \frac{a-2}{12-3} \quad (5)$$

$$\therefore 3a - 18 = 24.$$

$$\therefore a = 14. \quad (5)$$

find radius - 10

The radius of the required circle $C_2 = \sqrt{(12-6)^2 + (14-6)^2}$
 $= 10. \quad (5)$

Hence, the required equation is $(x-12)^2 + (y-14)^2 = 100. \quad (5)$

Me-11
 $5 + \sqrt{(12-6)^2 + (14-6)^2} = \sqrt{(12-3)^2 + (14-2)^2}$

25

$$\begin{aligned} 9a^2 - 252a + 1764 &= 0 \\ a^2 - 28a + 196 &= 0 \\ (a-14)^2 &= 0 \Rightarrow a = 14 \end{aligned}$$

144 / 196 / 40

10. Show that $\cos 5\theta = \cos 3\theta$ if and only if $\theta = \frac{n\pi}{4}$ for $n \in \mathbb{Z}$.

Show also that $\frac{\sin 5\theta - \sin 3\theta}{\cos 5\theta - \cos 3\theta} = -\cot 4\theta$ for $\theta \neq \frac{n\pi}{4}$ and $n \in \mathbb{Z}$.

$$\cos 5\theta = \cos 3\theta$$

$$\Leftrightarrow 5\theta = 2n\pi \pm 3\theta \text{ for } n \in \mathbb{Z}, \quad (5)$$

\Leftrightarrow not important

$$\Leftrightarrow 8\theta = 2n\pi \text{ or } 2\theta = 2n\pi \text{ for } n \in \mathbb{Z},$$

$$\Leftrightarrow \theta = \frac{n\pi}{4} \text{ or } \theta = n\pi \text{ for } n \in \mathbb{Z}, \quad (5)$$

$$\Leftrightarrow \theta = \frac{n\pi}{4} \text{ for } n \in \mathbb{Z},$$

$$\frac{\sin 5\theta - \sin 3\theta}{\cos 5\theta - \cos 3\theta} = \frac{2 \cos 4\theta \sin \theta}{-2 \sin 4\theta \sin \theta} \quad (5)$$

$$= -\cot 4\theta \quad (5)$$

25

Part B

* Answer five questions only.

11. (a) Let $0 < |p| < 1$. Show that the equation $p^2x^2 - 2x + 1 = 0$ has real distinct roots.

Let α and β ($\beta > \alpha$) be these roots. Show that α and β are both positive.

Find $(\alpha-1)(\beta-1)$ in terms of p , and deduce that $\alpha < 1$ and $\beta > 1$.

Show that $\sqrt{\beta} - \sqrt{\alpha} = \frac{1}{|p|} \sqrt{2(1-|p|)}$

It is given that $\sqrt{\beta} + \sqrt{\alpha} = \frac{1}{|p|} \sqrt{2(1+|p|)}$. Show that the quadratic equation whose roots are

$|\sqrt{\alpha}-1|$ and $|\sqrt{\beta}-1|$ is $|p|x^2 - \sqrt{2(1-|p|)}x + \sqrt{2(1+|p|)} - |p| - 1 = 0$.

(b) Let $p(x) = 2x^3 + ax^2 + bx - 4$, where $a, b \in \mathbb{R}$. It is given that $(x+2)$ is a factor of both $p(x)$ and $p'(x)$, where $p'(x)$ is the derivative of $p(x)$ with respect to x . Find the values of a and b . For these values of a and b , completely factorise $p(x) - 3p'(x)$.

(a)

$0 < |p| < 1$.

Let Δ be the discriminant of $p^2x^2 - 2x + 1 = 0$.

$\therefore \Delta = 4 - 4p^2 = 4(1 - p^2) > 0$, since $p^2 < 1$.

5 5 5

\therefore The equation has real distinct roots.

Handwritten: ≥ 0 Not give 05 marks

15

Let α and β ($\beta > \alpha$) be these roots.

Then $\alpha\beta = \frac{1}{p^2} > 0$. 5

α and β are both positive or both negative.

But, $\alpha + \beta = \frac{2}{p^2} > 0$ gives α and β are both positive. 5

15

$(\alpha-1)(\beta-1) = \alpha\beta - (\alpha + \beta) + 1 = \frac{1}{p^2} - \frac{2}{p^2} + 1 = \frac{p^2 - 1}{p^2} < 0$ and $\alpha - 1 < \beta - 1$.

5 5 5

Handwritten: since $\beta > \alpha$ plus 05

$\therefore \alpha - 1 < 0$ and $\beta - 1 > 0$. 5

$\therefore \alpha < 1$ and $\beta > 1$.

20

PAPERMASTER.LK

$$(\sqrt{\beta} - \sqrt{\alpha})^2 = \alpha + \beta - 2\sqrt{\alpha\beta} = \frac{2}{p^2} - 2 \frac{1}{|p|} = \frac{2}{p^2}(1 - |p|).$$

$$\therefore \sqrt{\beta} - \sqrt{\alpha} = \frac{1}{|p|} \sqrt{2(1 - |p|)}$$

15

The required equation is $(x - |\sqrt{\alpha} - 1|)(x - |\sqrt{\beta} - 1|) = 0.$

$$x^2 - (|\sqrt{\alpha} - 1| + |\sqrt{\beta} - 1|)x + |\sqrt{\alpha} - 1||\sqrt{\beta} - 1| = 0$$

Since $|\sqrt{\alpha} - 1| = 1 - \sqrt{\alpha}$ and $|\sqrt{\beta} - 1| = \sqrt{\beta} - 1$ we have

$$x^2 - (\sqrt{\beta} - \sqrt{\alpha})x + \sqrt{\alpha} + \sqrt{\beta} - \sqrt{\alpha\beta} - 1 = 0$$

$$\therefore x^2 - \frac{1}{|p|} \sqrt{2(1 - |p|)}x + \frac{1}{|p|} \sqrt{2(1 + |p|)} - \frac{1}{|p|} - 1 = 0$$

$$\therefore |p|x^2 - \sqrt{2(1 - |p|)}x + \sqrt{2(1 + |p|)} - |p| - 1 = 0$$

20

$$p(x) = 2x^3 + ax^2 + bx - 4$$

$$\therefore p'(x) = 6x^2 + 2ax + b.$$

Since $(x + 2)$ is a factor of $p(x)$,

We have $p(-2) = 0.$

Now, $p(-2) = -16 + 4a - 2b - 4 = 0.$

$$\therefore 2a - b = 10 \text{ ----- (1)}$$

Since $(x + 2)$ is a factor of $p'(x)$,

We have $p'(-2) = 0.$

Now, $p'(-2) = 24 - 4a + b = 0.$

$$\therefore 4a - b = 24. \text{ ----- (2)}$$

(1) and (2) $\Rightarrow a=7$ and $b=4$
 (5) (5)

35

$$\begin{aligned}
 p(x) - 3p'(x) &= (2x^3 + 7x^2 + 4x - 4) - 3(6x^2 + 14x + 4) \quad (5) \\
 &= (x+2)(2x^2 + 3x - 2) - 3(x+2)(6x+2) \quad (5) \\
 &= (x+2)[2x^2 + 3x - 2 - 18x - 6] \\
 &= (x+2)(2x^2 - 15x - 8) \quad (5) \\
 &= (x+2)(2x+1)(x-8) \quad (5) \quad (5) \quad (5)
 \end{aligned}$$

30

Aliter

$$p(x) = 2x^3 + ax^2 + bx - 4$$

Since $(x+2)$ is a factor of both $p(x)$ and $p'(x)$, we can write

$$p(x) = (x+2)^2(2x+k) \quad (5) \quad \text{where } k \text{ is a constant.}$$

(10)

By comparing the constant terms, we have $4k = -4$

$$\therefore k = -1 \quad (5)$$

$$\therefore p(x) = (x+2)^2(2x-1).$$

$$\therefore p(x) = (x^2 + 4x + 4)(2x - 1) = 2x^3 + 7x^2 + 4x - 4. \quad (5)$$

By comparing the coefficients of powers of x : $b=4$ and $a=7$.

PAPERMASTER (5) (5)

35

$$\therefore p(x) = 2x^3 + 7x^2 + 4x - 4$$

$$\therefore p'(x) = 6x^2 + 14x + 4 = 2(3x^2 + 7x + 2) = 2(x+2)(3x+1) \quad (5)$$

$$\therefore p(x) - 3p'(x) = (x+2)^2(2x-1) - 3(2(x+2)(3x+1)) \quad (5)$$

$$= (x+2)[(x+2)(2x-1) - 6(3x+1)]$$

$$= (x+2)(2x^2 - 15x - 8) \quad (5)$$

$$= (x+2)(2x+1)(x-8) \quad (5)$$

$$(5) \quad (5)$$

30

Q11

15	15	20	15	20	35	30
----	----	----	----	----	----	----

PAPERMASTER.LK

12.(a) Six mangoes and four oranges are to be distributed among eight students so that each student receives at least one fruit.

Find the number of different ways in which

- (i) six students get one fruit each and out of the remaining two students one gets two mangoes and the other gets two oranges,
- (ii) seven students get one fruit each, and the other student gets three mangoes,
- (iii) seven students get one fruit each, and the other student gets three fruits.

(b) Let $U_r = \frac{4(2r+7)}{(2r+1)(2r+3)(2r+5)}$ for $r \in \mathbb{Z}^+$. Also, let $f(r) = \frac{A}{(2r+1)} + \frac{B}{(2r+3)}$ for $r \in \mathbb{Z}^+$, where A and B are real constants. Determine the values of A and B such that $U_r = f(r) - f(r+1)$ for $r \in \mathbb{Z}^+$.

Hence or otherwise, show that $\sum_{r=1}^n U_r = \frac{4}{5} - \frac{3}{2n+3} + \frac{1}{2n+5}$ for $n \in \mathbb{Z}^+$.

Deduce that the infinite series $\sum_{r=1}^{\infty} U_r$ is convergent and find its sum.

Hence, find the value of the real constant k such that $\sum_{r=1}^{\infty} (U_r + kU_{r+1}) = 1$.

(a) (i)

2 students

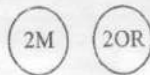

$8C_2$

x

6 students



$${}^6C_4 \times {}^2C_2$$

$${}^6C_2 \binom{2}{1} \binom{2}{1} = 840$$

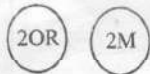

$8C_2$

x

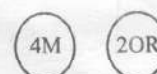

$${}^6C_4 \times {}^2C_2$$

$$\frac{25}{25}$$

Answer : $2 \times {}^8C_2 \times \binom{6}{4} \times {}^2C_2$ (5)

(05) (10) games

$$= 2 \times \frac{8!}{6!2!} \times \frac{6!}{4!2!} = 2 \times 28 \times 15 = 840 \text{ ways.} \quad (5)$$

(5)

25

3M

8C_1 x ${}^7C_3 \times {}^4C_4$

05

05

05

தேவையான வழிகள்: ${}^8C_1 \times {}^7C_3 \times {}^4C_4 = 8 \times 4 \frac{7!}{4!3!} = 8 \times 35 = 280$.

5 5 5

15

(iii) 3-பழம் : ${}^3M + {}^3OR + {}^2M + {}^1OR + {}^1M + {}^2OR$ 5

4 வகைகள்

3M வகை 280 வழிகள் (ii) இல் உள்ளவாறு

3OR வகை ${}^8C_1 \times {}^7C_3 \times {}^1C_1 = 8 \times 7 = 56$ வழிகள் 5

2M + 1OR வகை ${}^8C_1 \times {}^7C_4 \times {}^3C_3 = 8 \times 35 = 280$ வழிகள் 5

1M + 2OR வகை ${}^8C_1 \times {}^7C_5 \times {}^2C_2 = 8 \times 21 = 168$ வழிகள் 5

தேவையான வழிகள் = $280 + 56 + 280 + 168$

= 784 5

25

வேறு முறை:

(a) மாம்பழங்கள் 6; தோடம்பழங்கள் 4; மாணவர்கள் 8.

(i) ஒரு மாணவனுக்கு 2 மாம்பழங்களும், இன்னொருவருக்கு 2 தோடம்பழங்களும் வழங்கப்படுவதால் 6 மாணவர்கள் 4 மாம்பழங்கள், 2 தோடம்பழங்களில் இருந்து ஒவ்வொன்றை பெறுவர்.

						2Ma	2Or
--	--	--	--	--	--	-----	-----

$$\begin{aligned} \text{Total Number of ways} &= 280 + 280 + 168 + 56 \\ &= 784 \end{aligned}$$

5

25

(b). $r \in \mathbb{Z}^+$

$$U_r = \frac{4(2r+7)}{(2r+1)(2r+3)(2r+5)}$$

$$U_r = f(r) - f(r+1)$$

$$\frac{4(2r+7)}{(2r+1)(2r+3)(2r+5)} = \frac{A}{2r+1} + \frac{B}{2r+3} - \frac{A}{2r+3} - \frac{B}{2r+5}$$

$$\begin{aligned} \therefore 4(2r+7) &= A(2r+3)(2r+5) + (B-A)(2r+1)(2r+5) - B(2r+1)(2r+3) \\ &= (4A+4B)r + 10A - 2B \end{aligned}$$

Any Method

10

Comparing coefficient of powers of r :

$$r : 8 = 4A + 4B \Rightarrow 2 = A + B$$

$$r^0 : 28 = 10A + 2B \Rightarrow 14 = 5A + B$$

$$\left. \begin{array}{l} 5 \\ 5 \end{array} \right\} \begin{array}{l} A=3, \\ B=-1 \end{array}$$

25

$$U_r = f(r) - f(r+1) \quad \text{where} \quad f(r) = \frac{3}{2r+1} - \frac{1}{2r+3}$$

$$\left. \begin{array}{l} r=1; U_1 = f(1) - f(2) \\ r=2; U_2 = f(2) - f(3) \end{array} \right\}$$

$$\left. \begin{array}{l} r=n-1; U_{n-1} = f(n-1) - f(n) \\ r=n; U_n = f(n) - f(n+1) \end{array} \right\}$$

$$\sum_{r=1}^n U_r = f(1) - f(n+1)$$

A, B wrong gives 20 marks

$$u_{n+1} = f(n+1) - f(n)$$

$$u_2 = f(2) - f(1)$$

$$u_3 = f(3) - f(2)$$

$$\therefore \sum_{r=1}^n U_r = f(1) - f(n+1)$$

$$= 1 - \frac{1}{5} - \frac{3}{2n+3} + \frac{1}{2n+5}$$

$$= \frac{4}{5} - \frac{3}{2n+3} + \frac{1}{2n+5} \quad (5) \quad r \in \mathbb{Z}$$

30

$$u_n = f(n) - f(n+1)$$

$$u_{n+1} = f(n+1) - f(n+2)$$

$$\sum_{r=2}^n u_{n+1} = f(2) - f(n+2)$$

$$f(2) = \frac{3}{5} - \frac{1}{7} = \frac{16}{35}$$

Important

$$\lim_{n \rightarrow \infty} \sum_{r=1}^n U_r \quad (5)$$

$$= \lim_{n \rightarrow \infty} \left(\frac{4}{5} - \frac{3}{2n+3} + \frac{1}{2n+5} \right)$$

$$= \frac{4}{5} \rightarrow (5) \quad (5)$$

\therefore The infinite series $\sum_{r=1}^{\infty} U_r$ is convergent and the sum is $\frac{4}{5}$. (5)

15

$$\sum_{r=1}^{\infty} (U_r + kU_{r+1}) = 1$$

$$\sum_{r=1}^{\infty} U_r + k \sum_{r=1}^{\infty} U_{r+1} = 1$$

$$\frac{4}{5} + k(u_2 + u_3 + \dots + u_n + u_{n+1}) = 1$$

$$\frac{4}{5} + k \left(\sum_{r=1}^{\infty} U_r - U_1 \right) = 1$$

$$\frac{4}{5} + k \left(\frac{4}{5} - \frac{12}{35} \right) = 1$$

$$k = \frac{7}{16}$$

$$1 = \sum_{r=1}^{\infty} (U_r + kU_{r+1})$$

$$= (1+k) \left(\sum_{r=1}^{\infty} U_r \right) - kU_1 \quad (5)$$

$$= (1+k) \left(\frac{4}{5} \right) - k \left(\frac{12}{35} \right) \quad (5)$$

$$\therefore k = \frac{7}{16} \quad (5)$$

$$\sum_{r=1}^{\infty} u_r + k \sum_{r=2}^{\infty} u_r = 1$$

$$\frac{4}{5} + k \left(\frac{16}{35} \right) = 1$$

$$k = \frac{7}{16}$$

gives 10 marks

15

Q \Rightarrow 12

25	15	25	25	30	15	15
----	----	----	----	----	----	----

13.(a) Let $A = \begin{pmatrix} a & -2 \\ 1 & a+2 \end{pmatrix}$. Show that A^{-1} exists for all $a \in \mathbb{R}$.

The matrices $P = \begin{pmatrix} 1 & 0 & -1 \\ 0 & 1 & -2 \end{pmatrix}$, $Q = \begin{pmatrix} 2 & 3 & 2 \\ -1 & 7 & 4 \end{pmatrix}$ and $R = \begin{pmatrix} 1 & 3 \\ 2 & 4 \end{pmatrix}$ are such that $A = PQ^T + R$. Show that $a = 1$.

For this value of a , write down A^{-1} and hence, find the values of x and y such that

$$A \begin{pmatrix} x \\ y \end{pmatrix} = \begin{pmatrix} -5 \\ 10 \end{pmatrix}.$$

(b) Let $z, w \in \mathbb{C}$. Show that $\overline{z}z = |z|^2$ and hence, show that $|z+w|^2 = |z|^2 + 2\operatorname{Re}(z\overline{w}) + |w|^2$.

Deduce that $|z+w|^2 + |z-w|^2 = 2(|z|^2 + |w|^2)$ and give a geometric interpretation for it when the points representing z , w and 0 in the Argand diagram are non-collinear.

(c) Let $z = -1 + \sqrt{3}i$. Express z in the form $r(\cos\theta + i\sin\theta)$, where $r > 0$ and $\frac{\pi}{2} < \theta < \pi$.

Let $z^n = a_n + ib_n$, where $a_n, b_n \in \mathbb{R}$ for $n \in \mathbb{Z}^+$. Write down $\operatorname{Re}(z^m \cdot z^n)$ in terms of a_m, a_n, b_m and b_n for $m, n \in \mathbb{Z}^+$.

Considering z^{m+n} and using De Moivre's theorem, show that $a_m a_n - b_m b_n = 2^{m+n} \cos(m+n) \frac{2\pi}{3}$, for $m, n \in \mathbb{Z}^+$.

(a) $|A| = a(a+2) + 2 = a^2 + 2a + 2 = (a+1)^2 + 1 \neq 0$ for all $a \in \mathbb{R}$. (5)

(5) ↑ gives (15)

$\therefore A^{-1}$ exists for all $a \in \mathbb{R}$ (5)

15

$A = PQ^T + R$ (5)

$$\begin{pmatrix} a & -2 \\ 1 & a+2 \end{pmatrix} = \begin{pmatrix} 1 & 0 & -1 \\ 0 & 1 & -2 \end{pmatrix} \begin{pmatrix} 2 & -1 \\ 3 & 7 \\ 2 & 4 \end{pmatrix} + \begin{pmatrix} 1 & 3 \\ 2 & 4 \end{pmatrix} \quad (5)$$

$$= \begin{pmatrix} 0 & -5 \\ -1 & -1 \end{pmatrix} + \begin{pmatrix} 1 & 3 \\ 2 & 4 \end{pmatrix} \quad (5)$$

$$= \begin{pmatrix} 1 & -2 \\ 1 & 3 \end{pmatrix} \quad (5)$$

$a = 1$ and $a + 2 = 3$. $\therefore a = 1$ (5)

25

When $a=1$, $A = \begin{pmatrix} 1 & -2 \\ 1 & 3 \end{pmatrix} \therefore A^{-1} = \frac{1}{5} \begin{pmatrix} 3 & 2 \\ -1 & 1 \end{pmatrix}$

$|A| \Delta$ unvarying
gives 05

$$A \begin{pmatrix} x \\ y \end{pmatrix} = \begin{pmatrix} -5 \\ 10 \end{pmatrix}$$

10

$$\therefore \begin{pmatrix} x \\ y \end{pmatrix} = A^{-1} \begin{pmatrix} -5 \\ 10 \end{pmatrix} = \frac{1}{5} \begin{pmatrix} 3 & 2 \\ -1 & 1 \end{pmatrix} \begin{pmatrix} -5 \\ 10 \end{pmatrix} = \begin{pmatrix} 1 \\ 3 \end{pmatrix}$$

$$\therefore x=1 \quad \text{and} \quad y=3.$$

30

(b) Taking $z = x + iy$; $x, y \in \mathbb{R}$, we have

$$z\bar{z} = (x + iy)(x - iy) = x^2 - i^2 y^2 = x^2 + y^2 = |z|^2$$

5

5

10

$$|z + w|^2 = (z + w)(\overline{z + w})$$

$$= (z + w)(\bar{z} + \bar{w})$$

$$= z\bar{z} + z\bar{w} + \bar{z}w + w\bar{w}$$

$$= |z|^2 + z\bar{w} + \bar{z}w + |w|^2$$

$$= |z|^2 + 2\text{Re}(z\bar{w}) + |w|^2$$

(i)

20

(i) with w replace by $-w$,

$$|z - w|^2 = |z|^2 - 2\text{Re}(z\bar{w}) + |w|^2$$

(ii)

\therefore By (i) and (ii)

$$|z + w|^2 + |z - w|^2 = 2(|z|^2 + |w|^2)$$

5

Q13

15	25	30	10	20	15	15	05	15
----	----	----	----	----	----	----	----	----

$\alpha - 1 < 0$ $\beta - 1 > 0$
 $\alpha - 1 > 0$ $\beta - 1 < 0$

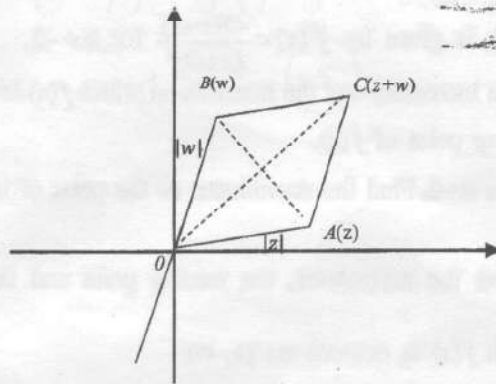

If z, w and 0 are non-collinear, then $OC^2 + AB^2 = 2(OA^2 + OB^2)$.

($\because OC = |z+w|$ and $AB = |z-w|$) $AB \perp |z-w|$

In a parallelogram, sum of the squares of the diagonals is equal to twice the sum of the squares of its sides.

5

15

(c) $z = -1 + \sqrt{3}i = 2\left(\frac{-1}{2} + \frac{\sqrt{3}}{2}i\right) = 2\left(\cos\frac{2\pi}{3} + i\sin\frac{2\pi}{3}\right)$

5

10

Here $r = 2$, and $\theta = \frac{2\pi}{3}$.

15

$\text{Re}(z^m z^n) = \text{Re}[(a_m + ib_m)(a_n + ib_n)] = a_m a_n - b_m b_n$ ----- (1)

5

05

$z^m z^n = z^{m+n} = \left[2\left(\cos\frac{2\pi}{3} + i\sin\frac{2\pi}{3}\right)\right]^{m+n} = 2^{m+n} \left[\cos\frac{2(m+n)\pi}{3} + i\sin\frac{2(m+n)\pi}{3}\right]$

$\therefore \text{Re}(z^m z^n) = 2^{m+n} \cos(m+n) \frac{2\pi}{3}$ ----- (2)

5

(1) and (2) $\Rightarrow a_m a_n - b_m b_n = 2^{m+n} \cos(m+n) \frac{2\pi}{3}$

15

14.(a) Let $f(x) = \frac{2x+3}{(x+2)^2}$, for $x \neq -2$.

Show that $f'(x)$, the derivative of $f(x)$, is given by $f'(x) = \frac{-2(x+1)}{(x+2)^3}$ for $x \neq -2$.

Hence, find the interval on which $f(x)$ is increasing and the intervals on which $f(x)$ is decreasing. Also, find the coordinates of the turning point of $f(x)$.

It is given that $f''(x) = \frac{2(2x+1)}{(x+2)^4}$ for $x \neq -2$. Find the coordinates of the point of inflection of the graph of $y = f(x)$.

Sketch the graph of $y = f(x)$ indicating the asymptotes, the turning point and the point of inflection.

State the smallest value of k for which $f(x)$ is one-one on $[k, \infty)$.

(b) The shaded region shown in the figure is of area 45 m^2 .

It is obtained by removing a rectangle of length $x \text{ m}$ and width $y \text{ m}$ from a rectangle of length $3x \text{ m}$ and width $2y \text{ m}$. Show that the perimeter $L \text{ m}$ of the shaded region is given by $L = 6x + \frac{54}{x}$ for $x > 0$.

Find the value of x such that L is minimum.

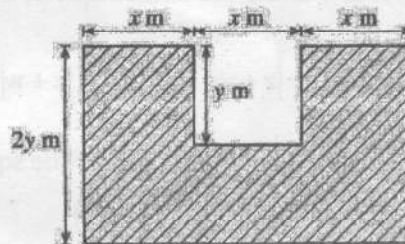

(a) For $x \neq -2$, $f(x) = \frac{2x+3}{(x+2)^2}$.

$$f'(x) = \frac{(x+2)^2(2) - 2(2x+3)(x+2)}{(x+2)^4} \quad (20)$$

$$= \frac{2(x+2)[x+2-2x-3]}{(x+2)^4} \quad (5)$$

$$= \frac{-2(x+1)}{(x+2)^3} \quad (5)$$

25

$$f'(x) = 0 \Leftrightarrow x = -1 \quad (5)$$

	$-\infty < x < -2$	$-2 < x < -1$	$-1 < x < \infty$
sign of $f'(x)$	(-)	(+)	(-)
$f(x)$ is	decreasing ↘	increasing ↗	decreasing ↘
	(5)	(5)	(5)

$\therefore f(x)$ is increasing on $(-2, -1]$ and decreasing on $(-\infty, -2)$ and $[-1, \infty)$.

20

Turning point: $(-1, 1)$ is a local maximum.

5

5

$$f''(x) = \frac{2(2x+1)}{(x+2)^4}$$

$$f''(x) = 0 \Leftrightarrow x = -\frac{1}{2}$$

5

	$-2 < x < -\frac{1}{2}$	$-\frac{1}{2} < x < \infty$
Sign of $f''(x)$	(-)	(+)
Concavity	concave down	concave up

5

5

\therefore the point of inflection is $(-\frac{1}{2}, \frac{8}{9})$

5

Horizontal Asymptote: $\lim_{x \rightarrow \pm\infty} f(x) = 0$

$\therefore y = 0$

5

Vertical Asymptote : $x = -2$

5

$$\left(\lim_{x \rightarrow -2^+} f(x) = -\infty \text{ and } \lim_{x \rightarrow -2^-} f(x) = -\infty \right)$$

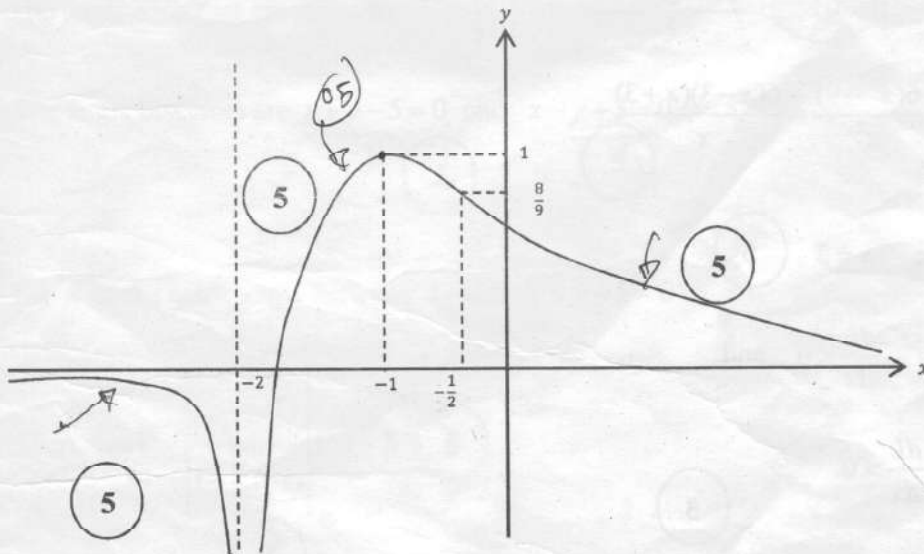

5

5

5

Smallest value of k , for which $f(x)$ is one to one on $[k, \infty)$ is $k = -1$.

5

05

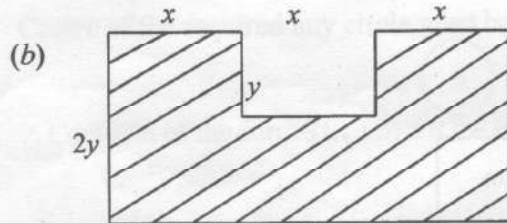

for $x > 0, y > 0$

5

5

Area of the shaded region, $45 = (3x)(2y) - xy$

$$\therefore 45 = 5xy$$

$$\therefore y = \frac{9}{x}$$

5

$$L = 6x + 6y \quad 10 / 0$$

$$= 6x + \frac{54}{x} \quad \text{for } x > 0$$

5

$$\frac{dL}{dx} = 6 - \frac{54}{x^2} = \frac{6(x^2 - 9)}{x^2} = \frac{6(x-3)(x+3)}{x^2}$$

5

$$\frac{dL}{dx} = 0 \quad \Leftrightarrow \quad x = 3$$

5

For $0 < x < 3$, $\frac{dL}{dx} < 0$ and

For $x > 3$, $\frac{dL}{dx} > 0$.

5

$\therefore L$ is minimum when $x = 3$.

45

Q14

25	20	55	05	45
----	----	----	----	----

15.(a) Find the values of the constants A , B and C such that

$$x^2 + x + 2 = A(x^2 + x + 1) + (Bx + C)(x + 1) \text{ for all } x \in \mathbb{R}.$$

Hence, write down $\frac{x^2 + x + 2}{(x^2 + x + 1)(x + 1)}$ in partial fractions and find $\int \frac{x^2 + x + 2}{(x^2 + x + 1)(x + 1)} dx$.

(b) Show that $1 + \sin 2x = 2 \cos^2\left(\frac{\pi}{4} - x\right)$ and hence, show that $\int_0^{\frac{\pi}{2}} \frac{1}{1 + \sin 2x} dx = 1$.

(c) Let $I = \int_0^{\frac{\pi}{2}} \frac{x^2 \cos 2x}{(1 + \sin 2x)^2} dx$. Using integration by parts, show that $I = -\frac{\pi^2}{8} + J$, where $J = \int_0^{\frac{\pi}{2}} \frac{x}{1 + \sin 2x} dx$.

Using the relation $\int_0^a f(x) dx = \int_0^a f(a-x) dx$ and the result in (b), evaluate J and show that $I = \frac{\pi}{8}(2 - \pi)$.

(a)

$$\begin{aligned} x^2 + x + 2 &= A(x^2 + x + 1) + (Bx + C)(x + 1) \\ &= (A + B)x^2 + (A + B + C)x + A + C \end{aligned}$$

Comparing the coefficients of powers of x :

$$\left. \begin{aligned} x^0: & \quad z = A + C \\ x: & \quad 1 = A + B + C \\ x^2: & \quad 1 = A + B \end{aligned} \right\} \quad (5)$$

$$\therefore A = 2, \quad B = -1 \quad \text{and} \quad C = 0. \quad (5)$$

$$\begin{matrix} (5) & (5) \end{matrix}$$

20

$$\frac{x^2 + x + 2}{(x^2 + x + 1)(x + 1)} = \frac{2}{x + 1} - \frac{x}{x^2 + x + 1} \quad (5)$$

$$\therefore \int \frac{x^2 + x + 2}{(x^2 + x + 1)(x + 1)} dx = 2 \int \frac{1}{x + 1} dx - \int \frac{x}{x^2 + x + 1} dx \quad (5)$$

PAPERMASTER.LK

$$\begin{aligned}
 &= 2\ln|x+1| - \frac{1}{2} \int \frac{2x+1}{x^2+x+1} dx + \frac{1}{2} \int \frac{1}{x^2+x+1} dx \\
 &= 2\ln|x+1| - \frac{1}{2} \ln(x^2+x+1) + \frac{1}{2} \frac{1}{\sqrt{3}} \tan^{-1} \frac{(x+\frac{1}{2})}{\frac{\sqrt{3}}{2}} + C \\
 & \quad \text{modulus important} \quad x^2+x+1 > 0
 \end{aligned}$$

$$= 2\ln|x+1| - \frac{1}{2} \ln(x^2+x+1) + \frac{1}{\sqrt{3}} \tan^{-1} \frac{(2x+1)}{\sqrt{3}} + C, \text{ where } C \text{ is an arbitrary constant.}$$

40

(b)

$$\begin{aligned}
 2 \cos^2\left(\frac{\pi}{4} - x\right) &= 2\left(\cos \frac{\pi}{4} \cos x + \sin \frac{\pi}{4} \sin x\right)^2 \\
 &= (\cos x + \sin x)^2 \\
 &= 1 + 2 \sin x \cos x \\
 &= 1 + \sin 2x
 \end{aligned}$$

15

$$\begin{aligned}
 \int_0^{\frac{\pi}{2}} \frac{1}{1 + \sin 2x} dx &= \int_0^{\frac{\pi}{2}} \frac{1}{2 \cos^2\left(\frac{\pi}{4} - x\right)} dx \\
 &= \frac{1}{2} \int_0^{\frac{\pi}{2}} \sec^2\left(\frac{\pi}{4} - x\right) dx \\
 &= \frac{-1}{2} \tan\left(\frac{\pi}{4} - x\right) \Big|_0^{\frac{\pi}{2}} \\
 &= \frac{-1}{2} \left(\tan\left(\frac{-\pi}{4}\right) - \tan \frac{\pi}{4} \right)
 \end{aligned}$$

PAPERMASTER.LK

$$= \frac{-1}{2}(-1-1)$$

$$= 1 \quad (5)$$

25

(C) $I = \int_0^{\frac{\pi}{2}} \frac{x^2 \cos 2x}{(1 + \sin 2x)^2} dx$

$$= x^2 \left(\frac{-1}{2} \right) \frac{1}{1 + \sin 2x} \Big|_0^{\frac{\pi}{2}} + \frac{1}{2} \int_0^{\frac{\pi}{2}} \frac{x}{1 + \sin 2x} dx \quad (5)$$

$$= \frac{-1}{2} \times \frac{\pi^2}{4} \times \frac{1}{1+0} \quad (5) + \int_0^{\frac{\pi}{2}} \frac{x}{1 + \sin 2x} dx$$

$$= \frac{-\pi^2}{8} + \int_0^{\frac{\pi}{2}} \frac{x}{1 + \sin 2x} dx$$

$$= \frac{-\pi^2}{8} + J. \quad (5)$$

25

$$J = \int_0^{\frac{\pi}{2}} \frac{x}{1 + \sin 2x} dx = \int_0^{\frac{\pi}{2}} \frac{\frac{\pi}{2} - x}{1 + \sin 2\left(\frac{\pi}{2} - x\right)} dx \quad (5)$$

$$= \frac{\pi}{2} \int_0^{\frac{\pi}{2}} \frac{1}{1 + \sin 2x} dx - \underbrace{\int_0^{\frac{\pi}{2}} \frac{x}{1 + \sin 2x} dx}_J \quad (5)$$

$$\therefore 2J = \frac{\pi}{2} \int_0^{\frac{\pi}{2}} \frac{1}{1 + \sin 2x} dx \quad (5)$$

$$\therefore J = \frac{\pi}{4} \quad (5)$$

$$\therefore I = \frac{-\pi^2}{8} + \frac{\pi}{4} = \frac{\pi}{8}(2 - \pi) \quad (5)$$

25

16. Let $P \equiv (x_0, y_0)$ and l be the straight line given by $ax+by+c=0$. Show that the perpendicular distance from P to l is $\frac{|ax_0+by_0+c|}{\sqrt{a^2+b^2}}$.

Let l_1 and l_2 be two straight lines given by $4x-3y+8=0$ and $3x-4y+13=0$, respectively. Show that l_1 and l_2 intersect at $A \equiv (1, 4)$.

Also, show that the parametric equations of the bisector of the acute angle between l_1 and l_2 can be written as $x=t$ and $y=t+3$, where $t \in \mathbb{R}$.

Hence, show that the equation of any circle touching both straight lines l_1 and l_2 , and lying in the region between l_1 and l_2 that contains the acute angle, is given by $(x-t)^2+(y-t-3)^2=\frac{1}{25}(t-1)^2$, where $t \in \mathbb{R}$ and $t \neq 1$.

From among the above circles, find the equations of the circles that intersect the circle centred at A of radius 1, orthogonally.

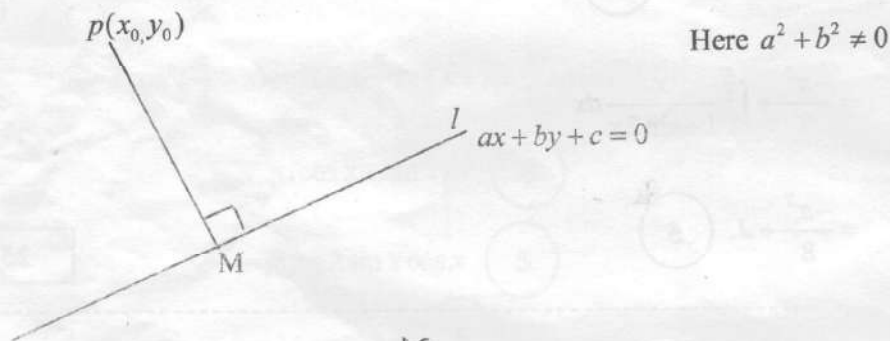

Equation of the line PM is $(y - y_0) = \frac{a}{b}(x - x_0)$ (5)

Any point on the line passing through P and perpendicular to l can be written as

$(x_0 + at, y_0 + bt)$ for $t \in \mathbb{R}$. (5)

M is on l ; $a(x_0 + at) + b(y_0 + bt) + c = 0$ (5)

$\therefore t(a^2 + b^2) = -ax_0 + by_0 + c$

$\therefore t = \frac{-(ax_0 + by_0 + c)}{a^2 + b^2}$ (5)

PAPERMASTER.LK

$$\begin{aligned} \therefore \text{Required distance } PM &= \sqrt{a^2t^2 + b^2t^2} && (5) \\ &= \sqrt{a^2 + b^2} |t| \\ &= \frac{|ax_0 + by_0 + c|}{\sqrt{a^2 + b^2}} && (5) \end{aligned}$$

30

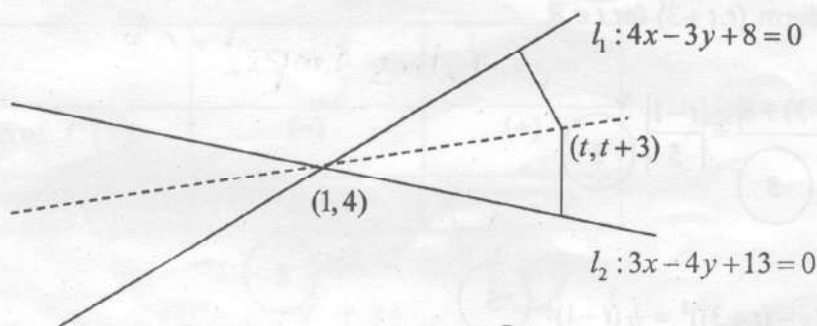

(5) (5)

Substituting the coordinates of A, to l_1 , and l_2 we get l_1 and l_2 intersect at $A = (1, 4)$ (5)

15

The angle bisectors are given by $\frac{4x - 3y + 8}{5} = \pm \frac{3x - 4y + 13}{5}$ (10)

The angle bisectors are $\underbrace{x + y - 5 = 0}_{m=-1}$ and $x - y + 3 = 0$. (5) (5)

Let θ be the acute angle between l_1 and $x + y - 5 = 0$

Then, $\tan \theta = \left| \frac{\frac{4}{3} - (-1)}{1 + \frac{4}{3}(-1)} \right| = 7 > 1$ (5)

(10)

(5)

not modulus give (5)

\therefore The acute angle bisector is $x - y + 3 = 0$ (5)

The acute angle bisector parametrically is given below.

PAPERMASTER.LK

Let $x = t$ for $t \in \mathbb{R}$. 5

Then $y = x + 3 = t + 3$. 5 55

Centre of the required any circle must be on the acute angle bisector.

\therefore Centre is of the form $(t, t + 3)$ for $t \in \mathbb{R}$ 5

Radius = $\frac{|4t - 3(t + 3) + 8|}{5}$ 5 = $\frac{|t - 1|}{5}$ 5 *modulus important*

\therefore The equation is $(x - t)^2 + (y - (t + 3))^2 = \frac{1}{25}(t - 1)^2$ 5

That is $(x - t)^2 + (y - t - 3)^2 = \frac{1}{25}(t - 1)^2$, where $t \in \mathbb{R}$. 20

Applying Pythagoras theorem to orthogonally intersecting circles gives

$(t - 1)^2 + (t + 3 - 4)^2 = 1^2 + \frac{1}{25}(t - 1)^2$ 10

$\therefore (t - 1)^2 = \frac{25}{49}$

$\Rightarrow t - 1 = \frac{5}{7}$ or $t - 1 = -\frac{5}{7}$

$\therefore t = \frac{12}{7}$ or $t = \frac{2}{7}$ 5 5

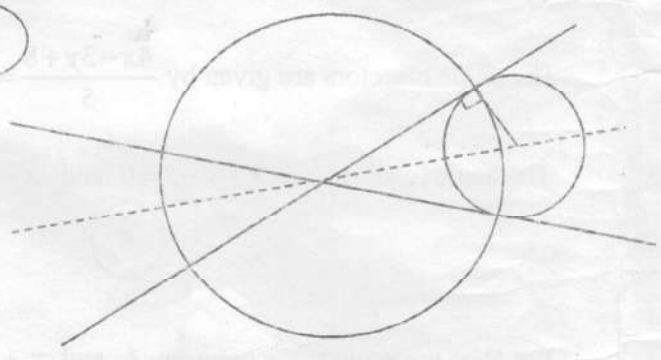

\therefore Equations of circles that intersects S orthogonally are

$\left(x - \frac{12}{7}\right)^2 + \left(y - \frac{33}{7}\right)^2 = \frac{1}{25} \left(\frac{12}{7} - 1\right)^2$ (when $t = \frac{12}{7}$) 5

$(7x - 12)^2 + (7y - 33)^2 = 1$

$$\left(x - \frac{2}{7}\right)^2 + \left(y - \frac{23}{7}\right)^2 = \frac{1}{25} \left(\frac{2}{7} - 1\right)^2 \quad \left(\text{when } t = \frac{2}{7}\right)$$

$$(7x - 2)^2 + (7y - 23)^2 = 1$$

5

30

Q.16

30	15	55	20	30
----	----	----	----	----

PAPERMASTER.LK

17.(a) Write down $\cos(A+B)$ in terms of $\cos A$, $\cos B$, $\sin A$ and $\sin B$, and obtain a similar expression for $\sin(A-B)$.

Let $k \in \mathbb{R}$ and $k \neq 1$. By separately considering the cases $k > 1$ and $k < 1$, express

$2k \cos\left(\theta + \frac{\pi}{3}\right) + 2 \sin\left(\theta - \frac{\pi}{6}\right)$ in the form $R \cos(\theta + \alpha)$, where $R (> 0)$ in terms of k , and $\alpha (0 < \alpha < 2\pi)$ are real constants to be determined.

Hence, solve $2k \cos\left(\theta + \frac{\pi}{3}\right) + 2 \sin\left(\theta - \frac{\pi}{6}\right) = |k-1|$.

(b) In the quadrilateral $ABCD$ shown in the figure $AB = 2p$, $CD = 4p$, $\widehat{ACB} = \frac{\pi}{6}$ and $\widehat{ABC} = \widehat{ACD} = \alpha$. Show that $AD^2 = 16p^2(\sin^2 \alpha - \sin 2\alpha + 1)$.

Hence, show that if $AD = 4p$, then $\alpha = \tan^{-1}(2)$.

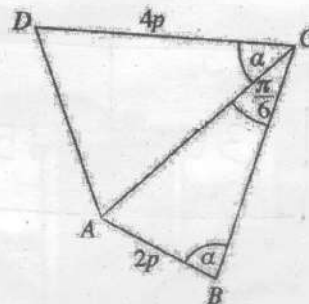

(c) Solve, $\tan^{-1}(\ln x^3) + \tan^{-1}(\ln x) + \tan^{-1}(\ln x^2) = \frac{\pi}{2}$ for $x > 1$.

(a) $\cos(A+B) = \cos A \cos B - \sin A \sin B$ (5)

$\sin(A-B) = \cos\left(\frac{\pi}{2} - (A-B)\right)$ (5)

$= \cos\left(\left(\frac{\pi}{2} - A\right) + B\right)$

$= \cos\left(\frac{\pi}{2} - A\right) \cos B - \sin\left(\frac{\pi}{2} - A\right) \sin B$ (5)

$= \sin A \cos B - \cos A \sin B$ (5)

20

direct working given (5)
 $\sin(A-B) = \sin A \cos B - \cos A \sin B$
 \neq

$2k \cos\left(\theta + \frac{\pi}{3}\right) + 2 \sin\left(\theta - \frac{\pi}{6}\right)$ (5)

$= 2k \left(\cos \theta \cos \frac{\pi}{3} - \sin \theta \sin \frac{\pi}{3} \right) + 2 \left(\sin \theta \cos \frac{\pi}{6} - \cos \theta \sin \frac{\pi}{6} \right)$ (5)

$= k(\cos \theta - \sqrt{3} \sin \theta) + (\sqrt{3} \sin \theta - \cos \theta)$ (5)

$= (k-1)(\cos \theta - \sqrt{3} \sin \theta)$

$= 2(k-1) \left(\frac{1}{2} \cos \theta - \frac{\sqrt{3}}{2} \sin \theta \right)$ (5)

$= 2(k-1) \cos(\theta + \beta)$ where $\beta = \frac{\pi}{3}$

5

$$\text{when } k > 1 \quad 2k \cos\left(\theta + \frac{\pi}{3}\right) + 2 \sin\left(\theta - \frac{\pi}{6}\right) = 2(k-1) \cos\left(\theta + \frac{\pi}{3}\right)$$

$$\text{where } R = 2(k-1) \text{ and } \alpha = \frac{\pi}{3}. \quad (5)$$

$$\begin{aligned} \text{when } k < 1 \quad 2k \cos\left(\theta + \frac{\pi}{3}\right) + 2 \sin\left(\theta - \frac{\pi}{6}\right) &= 2(1-k) \cos\left(\pi + \theta + \frac{\pi}{3}\right) \\ &= 2(1-k) \cos\left(\theta + \frac{4\pi}{3}\right) \end{aligned}$$

$$\text{where } R = 2(1-k) \text{ and } \alpha = \frac{4\pi}{3}. \quad (5)$$

35

$$2k \cos\left(\theta + \frac{\pi}{3}\right) + 2 \sin\left(\theta - \frac{\pi}{6}\right) = |k-1|$$

when $k > 1$

$$2(k-1) \cos\left(\theta + \frac{\pi}{3}\right) = k-1$$

$$\therefore \cos\left(\theta + \frac{\pi}{3}\right) = \frac{1}{2} \quad (5)$$

$$\Rightarrow \theta + \frac{\pi}{3} = 2n\pi \pm \frac{\pi}{3} \quad n \in \mathbb{Z}$$

$$\therefore \theta = 2n\pi - \frac{\pi}{3} \pm \frac{\pi}{3}, \text{ where } n \in \mathbb{Z}. \quad (5)$$

when $k < 1$

$$2(1-k) \cos\left(\theta + \frac{4\pi}{3}\right) = 1-k$$

$$\therefore \cos\left(\theta + \frac{4\pi}{3}\right) = \frac{1}{2} \quad (5)$$

$$\theta + \frac{4\pi}{3} = 2n\pi \pm \frac{\pi}{3} \quad n \in \mathbb{Z}.$$

$$\therefore \theta = 2n\pi - \frac{4\pi}{3} \pm \frac{\pi}{3}, \text{ where } n \in \mathbb{Z}. \quad (5)$$

20

PAPERMASTER.LK

(b) Sine Rule for the triangle ABC :

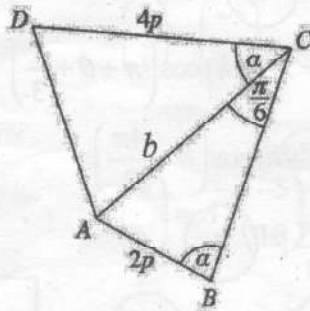

$$\frac{b}{\sin \alpha} = \frac{2p}{\sin \frac{\pi}{6}} \Rightarrow b = 4p \sin \alpha \quad (5)$$

Cosine Rule for the triangle ACD :

$$\begin{aligned} AD^2 &= b^2 + (4p)^2 - 2b(4p) \cos \alpha \quad (10) \\ &= 16p^2 \sin^2 \alpha + 16p^2 - 2(4p)^2 \sin \alpha \cos \alpha \\ &= 16p^2 (\sin^2 \alpha - \sin 2\alpha + 1) \quad (5) \end{aligned}$$

30

If $AD = 4p$, the ADC is an isosceles triangle, we have

$$\begin{aligned} \sin^2 \alpha - \sin 2\alpha + 1 &= 1 \\ \sin \alpha (\sin \alpha - 2 \cos \alpha) &= 0 \quad (5) \end{aligned}$$

Since $\sin \alpha \neq 0$,

$$\begin{aligned} \sin \alpha &= 2 \cos \alpha \quad (5) \\ \frac{\sin \alpha}{\cos \alpha} &= 2 \quad \cos \alpha \neq 0 \end{aligned}$$

$$\begin{aligned} \therefore \tan \alpha &= 2 \\ \alpha &= \tan^{-1}(2) \quad (5) \end{aligned}$$

15

Q17

	20	35	20	30	15	30
--	----	----	----	----	----	----

(c)

For $x > 1$

$$\underbrace{\tan^{-1}\left(\ln x^{\frac{2}{3}}\right)}_{\alpha} + \underbrace{\tan^{-1}(\ln x)}_{\beta} + \underbrace{\tan^{-1}(\ln x^2)}_{\theta} = \frac{\pi}{2}$$

$$\beta + \theta = \frac{\pi}{2} - \alpha \quad (5)$$

$$\tan(\beta + \theta) = \cot \alpha \quad (5)$$

$$\frac{\tan \beta + \tan \theta}{1 - \tan \beta \tan \theta} = \frac{1}{\tan \alpha} \quad (5)$$

$$\therefore \frac{\ln x + \ln x^2}{1 - \ln x \ln x^2} = \frac{1}{\ln x^{\frac{2}{3}}} \quad (5)$$

$$\frac{\ln x^3}{1 - 2(\ln x)^2} = \frac{1}{\frac{2}{3} \ln x}$$

Taking $t = \ln x$,

$$3 \times \frac{2}{3} t^2 = 1 - 2t^2 \quad (5)$$

$$4t^2 = 1$$

$$\ln x = t = \frac{1}{2} \quad (\because t \neq -\frac{1}{2} \text{ as } t = \ln x \text{ and } x > 1)$$

$$\therefore x = e^{\frac{1}{2}} \quad (5)$$

30

Verification

$$\tan^{-1}\left(\ln\left(e^{\frac{1}{2}}\right)^{\frac{2}{3}}\right) + \tan^{-1}\left(\ln e^{\frac{1}{2}}\right) + \tan^{-1}(\ln e) \doteq \frac{\pi}{2}$$

$$\Leftrightarrow \underbrace{\tan^{-1}\left(\frac{1}{3}\right) + \tan^{-1}\left(\frac{1}{2}\right)}_{\frac{\frac{1}{3} + \frac{1}{2}}{1 - \frac{1}{3} \cdot \frac{1}{2}}} \doteq \frac{\pi}{4}$$

$$\begin{aligned} &= \frac{5}{6} \\ &= \frac{5}{6} \\ &= 1 \end{aligned}$$

PAPERMASTER.LK



Department of Examinations - Sri Lanka

G.C.E. (A/L) Examination - 2022 (2023)

10 - Combined Mathematics II

Marking Scheme

This document has been prepared for the use of Marking Examiners. Some changes would be made according to the views presented at the Chief Examiners' meeting.

Amendments to be included

Part A

1. Three particles A, B and C, each of mass m , are placed in a straight line on a smooth horizontal table with A and B distance a apart, and connected by a light inextensible string of length a , as shown in the figure.



The particle B is given an impulse in the direction of \overrightarrow{AB} such that its velocity just after the impulse is u . Show that the velocity of B just after it collides with C is $\frac{1}{2}(1-e)u$ in the direction of \overrightarrow{AB} , where e is the coefficient of restitution between B and C.

Also, find the time taken, after this collision, for A to collide with B.

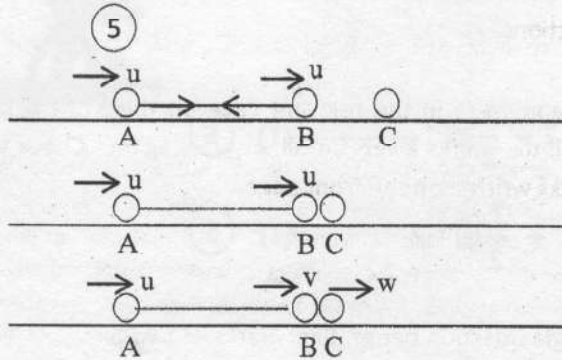

Apply $I = \Delta(mv)$ for B and C :

$$\rightarrow 0 = mv + mw - mu \rightarrow \textcircled{5}$$

$$\therefore v + w = u \dots\dots\dots (1)$$

Apply Newton's Law of restitution:

$$w - v = eu \dots\dots\dots (2) \textcircled{5}$$

$$(1) - (2) : 2v = u - eu$$

$$\therefore v = \frac{1}{2}(1-e)u \textcircled{5}$$

$$\begin{aligned} \text{Required time taken} &= \frac{a}{u-v} \\ &= \frac{2a}{(1+e)u} \textcircled{5} \end{aligned}$$

2. *A* and *B* are two points on a horizontal ground such that $AB = a$. Two particles *P* and *Q* are projected from the points *A* and *B* respectively, at the same instant and in the vertical plane that contains the line *AB* such that they collide with each other after a time *T* at a point in space. The initial velocities of *P* and *Q* are given in the figure.

Show that $u = \sqrt{ga}$ and find *T* in terms of *a* and *g*.

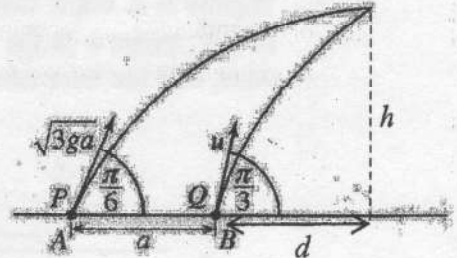
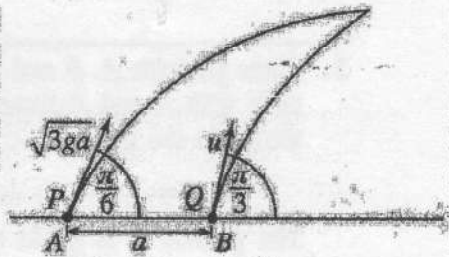

Apply $s = ut + \frac{1}{2}at^2$:

(P) $\uparrow h = \sqrt{3ga} \cdot \frac{1}{2} T - \frac{1}{2}gT^2$ (1) (5)

(Q) $\uparrow h = u \cdot \frac{\sqrt{3}}{2} \cdot T - \frac{1}{2}gT^2$ (2) (5)

(1) - (2) : $u \frac{\sqrt{3}}{2} T = \sqrt{3ga} \cdot \frac{1}{2} T$ \rightarrow (5)

$\Rightarrow u = \sqrt{ga}$

(P) $\rightarrow a + d = \sqrt{3ga} \frac{\sqrt{3}}{2} T$
 (Q) $\rightarrow d = \sqrt{ag} \cdot \frac{1}{2} \cdot T$ } (5) (for both)

$\therefore a + \frac{\sqrt{ag}}{2} T = 3 \frac{\sqrt{ag}}{2} T$

$\Rightarrow a = 2 \frac{\sqrt{ag}}{2} T$

$\Rightarrow T = \sqrt{\frac{a}{g}}$ (5)

3. Two particles A and B of masses m and $3m$, respectively, are attached to the ends of a light inextensible string. The particle A is held at rest on a horizontal table with the string passing over a small smooth pulley fixed at the edge of the table. The particle B hangs vertically below the pulley. The system is released from rest with the particle A at a distance a from the pulley. In the subsequent motion, a constant frictional force of magnitude $\frac{1}{2}mg$ acts on A. Find the acceleration of A. Also, find the speed of A at the instant when A reaches the pulley.

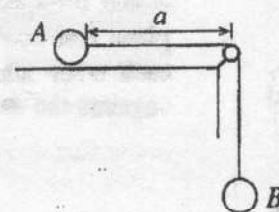

Apply $\vec{F} = m\vec{a}$

For B : $\downarrow 3mg - T = 3mf$ (1) (5)

For A : $\rightarrow T - \frac{1}{2}mg = mf$ (2) (5)

(1) - (2) : $\frac{5}{2}mg = 4mf$

$f = \frac{5}{8}g$ (5)

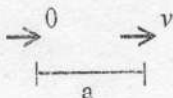

Apply $v^2 = u^2 + 2as$:

$v^2 = 2fa$ (5)

$\therefore v^2 = 2 \times \frac{\sqrt{5ag}}{8} \times a$

$\therefore v = \frac{\sqrt{5ag}}{2}$ (5)

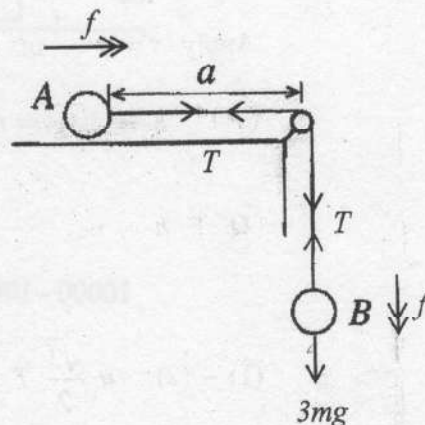

f is wrong

4. A car of mass 1500 kg working with a constant power 80 kW moves on a horizontal road against a constant resistance. The acceleration of the car is 2 m s^{-2} , when it moves with the speed 20 m s^{-1} . Obtain equations sufficient to determine the acceleration of the car when it moves upward on a road of inclination $\sin^{-1}\left(\frac{2}{3}\right)$ to the horizontal with speed 8 m s^{-1} working with the same constant power against the same constant resistance.

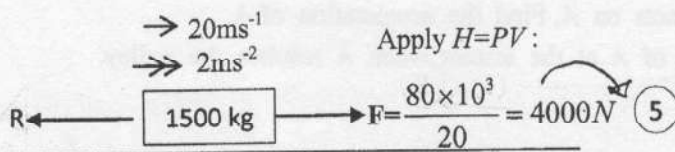

$$\text{Apply } \vec{F} = m\vec{a}: \rightarrow 4000 - R = 1500 \times 2 \quad (5)$$

$$\therefore R = 1000\text{N}$$

$$10000 - 1000 - 1500 \times \frac{2}{3}g = 1500a \quad (10) / 0$$

$$9000 - 1000g = 1500a$$

$$3a = 18 - 2g$$

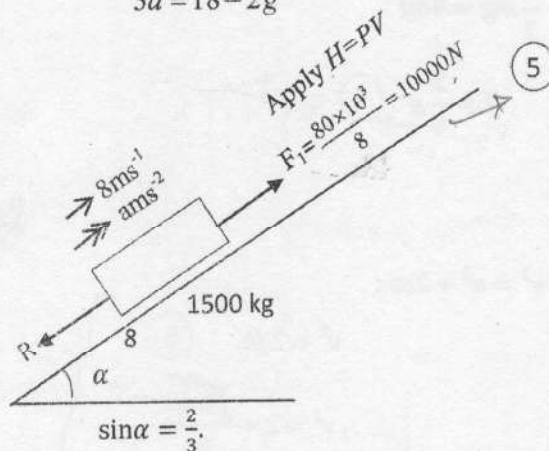

5. One end of a light inextensible string of length a is attached to a fixed point and the other end to a particle of mass m . The particle moves in a horizontal circle with constant angular speed ω . The string makes an angle θ ($0 < \theta < \frac{\pi}{2}$) with the downward vertical. Show that $\omega > \sqrt{\frac{g}{a}}$.

Apply $\vec{F} = m\vec{a}$

$$\uparrow T \cos \theta = mg \quad \text{----- (1) } \textcircled{5}$$

$$\leftarrow T \sin \theta = m\omega^2 a \sin \theta \quad \text{----- (2) } \textcircled{5}$$

$$\therefore T = m\omega^2 a$$

$$(1) \text{ and } (2): \Rightarrow \cos \theta = \frac{g}{\omega^2 a} \quad \textcircled{5}$$

$$\text{Since } 0 < \theta < \frac{\pi}{2}, \text{ we have } \cos \theta < 1. \quad \textcircled{5}$$

$$\therefore \frac{g}{\omega^2 a} < 1.$$

$$\therefore \omega > \sqrt{\frac{g}{a}} \quad \textcircled{5}$$

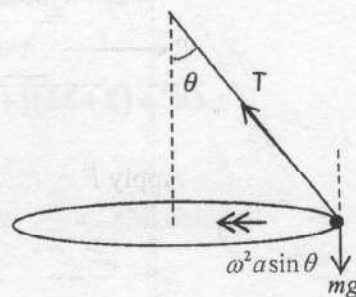

6. In the usual notation, the position vectors of two points A and B with respect to a fixed origin O are $3\mathbf{i} + 2\mathbf{j}$ and $2\mathbf{i} + 4\mathbf{j}$, respectively. Show that O , A and B are non-collinear.

Let C be the point such that $\overrightarrow{BC} = \lambda \overrightarrow{OA}$, where $\lambda \in \mathbb{R}$. Find \overrightarrow{OC} in terms of \mathbf{i} , \mathbf{j} and λ .

Show that if $\widehat{BOC} = \frac{\pi}{2}$, then $\lambda = -\frac{10}{7}$.

Since $3:2 \neq 2:4$, O , A and B are non-collinear. (5)

$$\begin{aligned} \overrightarrow{OC} &= \overrightarrow{OB} + \overrightarrow{BC} \quad (5) \\ &= 2\mathbf{i} + 4\mathbf{j} + \lambda(3\mathbf{i} + 2\mathbf{j}). \end{aligned}$$

$$\therefore \overrightarrow{OC} = (2 + 3\lambda)\mathbf{i} + (4 + 2\lambda)\mathbf{j}. \quad (5)$$

since $\widehat{BOC} = \frac{\pi}{2}$, we have $\overrightarrow{OB} \cdot \overrightarrow{OC} = 0$.

$$\therefore (2\mathbf{i} + 4\mathbf{j}) \cdot ((2 + 3\lambda)\mathbf{i} + (4 + 2\lambda)\mathbf{j}) = 0. \quad (5)$$

$$\therefore 4 + 6\lambda + 16 + 8\lambda = 0.$$

$$\therefore \lambda = -\frac{10}{7}. \quad (5)$$

$$\begin{aligned} \overrightarrow{OA} &= \lambda \overrightarrow{OB} \\ (3\mathbf{i} + 2\mathbf{j}) &\neq \lambda(2\mathbf{i} + 4\mathbf{j}) \end{aligned}$$

7. A uniform rod AB is kept in equilibrium with its upper end A resting on a smooth peg by applying a force P to its lower end B at an angle β to the vertical, as shown in the figure. The rod makes an angle $\frac{\pi}{6}$ with the horizontal. Show that $\tan \beta = \frac{\sqrt{3}}{5}$.

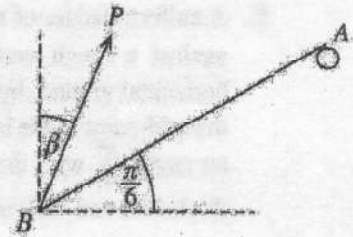

$$\triangle BMN; BM = a \cos \frac{\pi}{6} = a \frac{\sqrt{3}}{2} \quad (5)$$

$$MN = a \sin \frac{\pi}{6} = \frac{a}{2} \quad (5)$$

$$\triangle ALN; LN = \frac{a}{\cos \frac{\pi}{3}} = 2a \quad (5)$$

$$\therefore LM = 2a + \frac{a}{2} = \frac{5a}{2} \quad (5)$$

$$\triangle BLM; \tan \beta = \frac{BM}{LM} = \frac{a \frac{\sqrt{3}}{2}}{\frac{5a}{2}} = \frac{\sqrt{3}}{5} \quad (5)$$

$$\tan \beta = \frac{\sqrt{3}}{5}$$

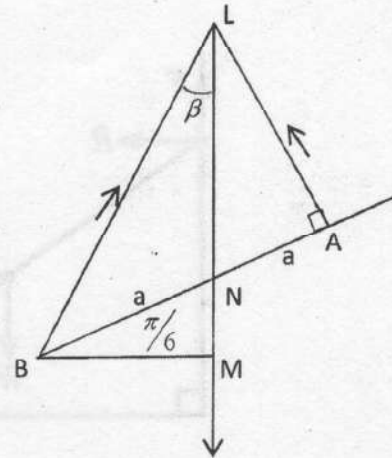

Aliter

$$B \curvearrowright W a \cos \frac{\pi}{6} = R \cdot (2a) \Rightarrow R = \frac{\sqrt{3}W}{4} \quad (5)$$

$$\uparrow P \cos \beta + R \cos \frac{\pi}{6} = W \quad (5)$$

$$P \cos \beta = W - \frac{\sqrt{3}}{4} \cdot \frac{\sqrt{3}W}{2} = \frac{5W}{8} \quad (5)$$

$$\rightarrow P \sin \beta = R \sin \frac{\pi}{6} \quad (5)$$

$$= \frac{\sqrt{3}W}{4} \left(\frac{1}{2} \right)$$

$$= \frac{\sqrt{3}W}{8}$$

$$\therefore \tan \beta = \frac{\sqrt{3}W}{8} \div \frac{5W}{8} = \frac{\sqrt{3}}{5} \quad (5)$$

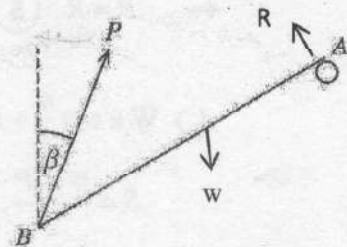

Aliter: (m+n) at-rule

8. A uniform ladder of weight W and length $2a$ is kept in equilibrium against a rough vertical wall with its lower end on a smooth horizontal ground, by a horizontal force of magnitude P applied at the mid-point of the ladder as shown in the figure. The ladder makes an angle $\frac{\pi}{4}$ with the ground. The coefficient of friction between the ladder and the wall is $\frac{1}{6}$. Show that, $\frac{3W}{4} \leq P \leq \frac{3W}{2}$.

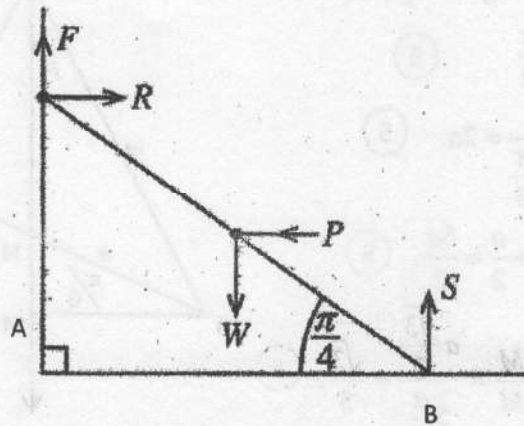
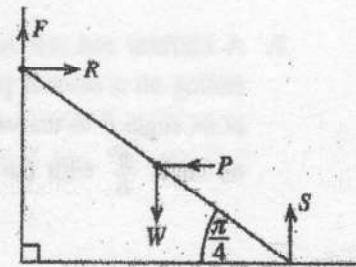

For the equilibrium of the ladder :

$$\uparrow F + S = W \quad (5)$$

$$\leftarrow P = R \quad (5)$$

$$A) \quad W a \cos \frac{\pi}{4} + P \cdot a \cdot \sin \frac{\pi}{4} - S \cdot 2a \cos \frac{\pi}{4} = 0 \quad (5)$$

$$\therefore S = \frac{W + P}{2},$$

$$\text{and } F = \frac{W - P}{2}.$$

$$\text{Now, } \frac{1}{6} \geq \frac{|F|}{R}$$

less. (05)

$$\Rightarrow -\frac{1}{6} \leq \frac{W - P}{2P} \leq \frac{1}{6}$$

$$\Rightarrow -P \leq 3(W - P) \leq P$$

$$\Rightarrow \frac{3W}{4} \leq P \leq \frac{3W}{2} \quad (10)$$

PAPERMASTER.LK

9. Let A and B be two events of a sample space Ω . It is given that $P(A) = \frac{2}{7}$, $P(A \cup B) = \frac{11}{14}$ and $P(A' \cup B') = \frac{4}{5}$. Find $P(B)$ and show that A and B are independent events.

$$P(A \cup B) = P(A) + P(B) - P(A \cap B) \rightarrow (5)$$

$$\Rightarrow \frac{11}{14} = \frac{2}{7} + P(B) - \frac{1}{5}$$

$$\therefore P(B) = \frac{7}{10} \rightarrow (5)$$

$$P(A \cap B) = 1 - P(A' \cup B') = \frac{1}{5} \rightarrow (5)$$

$$P(A)P(B) = \frac{2}{7} \times \frac{7}{10} = \frac{1}{5} = P(A \cap B). \quad (5)$$

$\therefore A$ and B are independent.

25

10. The mean and the standard deviation of marks obtained by 100 students for an examination are 60 and 20, respectively. Find the z-score of a student who obtained 56 marks for this examination. It was later found that this mark of 56 has been entered erroneously and it should have been 65 instead. Find the correct value of the mean of the marks obtained for this examination.

$$z = \frac{56 - 60}{20} = \frac{-4}{20} = \frac{-1}{5} = -0.2 \rightarrow (5)$$

$$60 = \mu_{old} = \frac{\sum_{i=1}^{100} x_i}{100} \Rightarrow \left(\sum_{i=1}^{100} x_i \right)_{old} = 6000 \quad (5)$$

$$\therefore \mu_{correct} = \frac{\left(\sum_{i=1}^{100} x_i \right)_{correct}}{100} = \frac{6000 - 56 + 65}{100} = \frac{6009}{100} = 60.09 \quad (5)$$

PAPERMASTER.LK

25

From $\triangle OCD$:

$$\frac{1}{2}(t_1)(2f t_1) = a \quad (5)$$

$$\Rightarrow t_1^2 = \frac{a}{f}$$

$$\therefore t_1 = \sqrt{\frac{a}{f}} \text{ as } t_1 > 0. \quad (5)$$

From $\triangle DEF$:

$$f = \frac{2f t_1}{t_2} \quad (5)$$

$$\therefore t_2 = 2t_1.$$

$$= 2\sqrt{\frac{a}{f}} \quad (5)$$

20

Let $a = 50$ and $f = 2$.

$$\text{Then } t_1 = \sqrt{\frac{50}{2}} = 5 \text{ and } t_2 = 10. \quad (5)$$

Since Q meets P at B , area of $OCED$ = area of EGI .

$$\therefore \frac{1}{2}(5+10)(2 \cdot 2 \cdot 5) = \frac{1}{2} + 3 \cdot 2t_3 \quad (5)$$

$$t_3^2 = 150$$

$$t_3 = \sqrt{150} = 5\sqrt{6}. \quad (5)$$

15

$$AB = \frac{1}{2}(t_2 + t_3)(2f t_1 + f t_3) \quad (5)$$

$$= \frac{1}{2}(10 + 5\sqrt{6})(5 \times 2 + 5\sqrt{6}) \cdot (2) = 50(5 + 5\sqrt{6}) \quad (5)$$

Full Markes

10

(b)

$$\left. \begin{aligned} \underline{V}(P,E) &= \downarrow 60 \\ \underline{V}(Q,E) &= \rightarrow 30\sqrt{3} \\ \underline{V}(R,P) &= \nearrow 30^\circ \\ \underline{V}(R,Q) &= \downarrow \\ \underline{V}(R,E) &= \underline{V}(R,P) + \underline{V}(P,E) \end{aligned} \right\} \textcircled{10}$$

Any two corrects give 05 marks

$$= \underline{V}(P,E) + \underline{V}(R,P)$$

$$= \underline{V}(R,P) + \underline{V}(P,E)$$

$$= \overline{AB} + \overline{AC} = \overline{AB} + \overline{BC}$$

$\triangle ABC$ 15

$$= \overline{AC}$$

Also, $\underline{V}(R,E) = \underline{V}(R,Q) + \underline{V}(Q,E)$

$$= \underline{V}(Q,E) + \underline{V}(R,Q)$$

$$= \overline{AD} + \overline{DC}$$

$\triangle ADC$ 15

$$= \overline{AC}$$

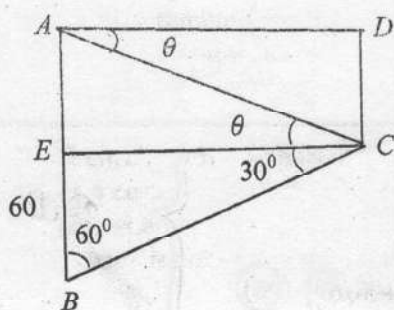

$$BE = 30\sqrt{3} \cdot \frac{1}{\sqrt{3}} = 30$$

$$\therefore AE = 30$$

$$\text{Also, } CE = 30\sqrt{3}$$

$$\tan \theta = \frac{AE}{CE} = \frac{1}{\sqrt{3}} \quad \textcircled{5}$$

$$\therefore \theta = 30^\circ \quad \textcircled{5}$$

PAPERMASTER.LK

Now $V^2 = (30\sqrt{3})^2 + 30^2$ (5)

$V^2 = 30^2 (4)$

$\therefore V = 60\text{ms}^{-1}$ (5)

60

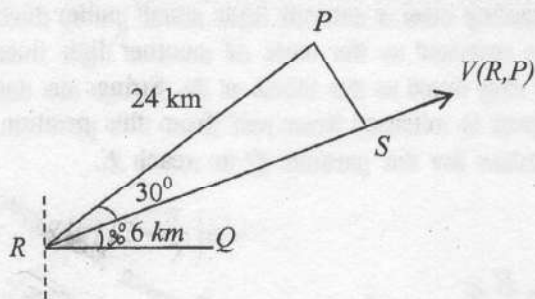

$RS = 24000 \sqrt{\frac{3}{2}}$

$= 12000\sqrt{3}$

$t = \frac{12000\sqrt{3}}{60}$

$= 200\sqrt{3} \text{ S}$ (5)

Let $d = 30 \times 200\sqrt{3} = 6000\sqrt{3}$

$= 6\sqrt{3} \text{ km}$ (5)

\therefore The required distance D km given by

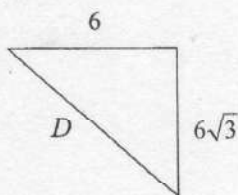

$D^2 = 6^2 + 6^2 (3)$

$= 6^2 (4)$

$\therefore D = 12 \text{ km.}$ (5)

15

PAPERMASTER.LK

Q11 \Rightarrow | 30 | 20 | 15 | 10 | 60 | 15 |

12.(a) The vertical cross-section $ABCDE$ through the centre of gravity of a smooth uniform block of mass $4m$ is shown in the figure. The face containing AB is placed on a smooth horizontal floor. Also, AE and ED are the lines of greatest slope of the faces containing them. $AE = 2a$, $ED = a$, $DC = a$ and $\hat{EAB} = \hat{AED} = \frac{\pi}{3}$. Three particles P , Q and R of masses $3m$, $2m$ and m , respectively, are placed at the mid-points of AE , ED and DC . The particles P and Q are attached to the ends of a light inextensible string passing over a smooth light small pulley fixed to the block at E , and the particles Q and R are attached to the ends of another light inextensible string passing through a smooth light small ring fixed to the block at D . Strings are taut in the position shown in the diagram and the system is released from rest from this position. Obtain equations sufficient to determine the time taken for the particle Q to reach E .

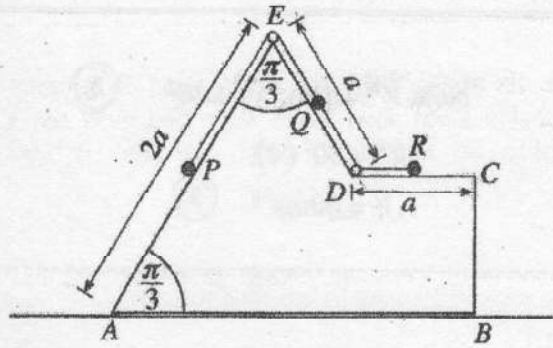

(a)

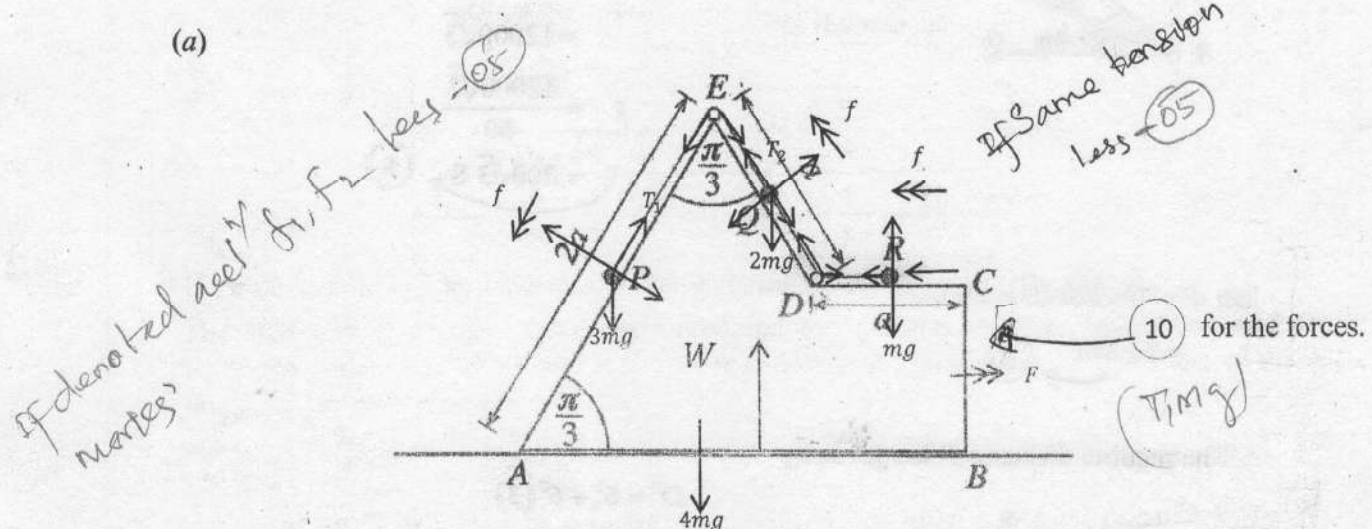

$$\vec{V}(W, E) = \rightarrow F$$

$$\vec{V}(P, W) = \swarrow f$$

$$\text{Then } \left. \begin{aligned} \vec{V}(Q, W) &= \swarrow f \\ \vec{V}(R, W) &= \leftarrow f \end{aligned} \right\} \begin{matrix} (5) \\ (5) \end{matrix}$$

Apply $F = ma$:

For P : $\swarrow 3mg \cos \frac{\pi}{6} - T_1 = 3m(f - F \cos \frac{\pi}{3}) \rightarrow (15)$

For Q : $\swarrow T_1 - T_2 - 2mg \cos \frac{\pi}{6} = 2m(f - F \cos \frac{\pi}{3}) (15)$

For R : $\leftarrow T_2 = m(f - F) (10) / 0$

one mistake less (20)

For the system :

→

$$0 = 4mF + m(F - f) + 2m(F - f \cos \frac{\pi}{3}) + 3m(F - f \cos \frac{\pi}{3}) \quad (20)$$

For Q ↖ $s = ut + \frac{1}{2}ft^2$

$$\Rightarrow \frac{a}{2} = \frac{1}{2}ft^2 \quad (10)$$

90

One mistake less
Two " " less
Three " " less
NON

(b) A cylinder of radius a is fixed with its axis horizontal and the adjoining figure shows a vertical cross-section of the cylinder perpendicular to its axis. Two particles P and Q of masses m and $2m$, respectively connected by a light inextensible string are held with the string taut and OP horizontal in the position as shown in the figure and released from rest. Assuming that the particle Q moves vertically downwards, show that the speed v of the particle P when \overrightarrow{OP} has turned through an angle θ ($0 \leq \theta \leq \frac{\pi}{6}$) is given by $v^2 = \frac{2ga}{3}(2\theta - \sin\theta)$.

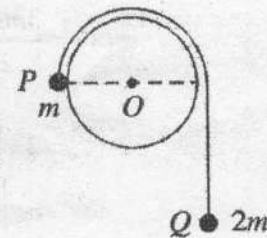

The string is cut when $\theta = \frac{\pi}{6}$ and it is given that the particle P moving on the cylinder comes to instantaneous rest before it reaches the highest point of the cylinder. In the subsequent motion, find the speed of P when it is at a distance a vertically below its initial position.

(b) By the conservation of energy, we have

$$\frac{1}{2}mv^2 + \frac{1}{2}2mv^2 + mga \sin\theta - 2ma\theta g = 0 \quad (25)$$

$$\Rightarrow 3v^2 = 2ag(2\theta - \sin\theta)$$

$$\Rightarrow v^2 = \frac{2ag}{3}(2\theta - \sin\theta) \quad (5)$$

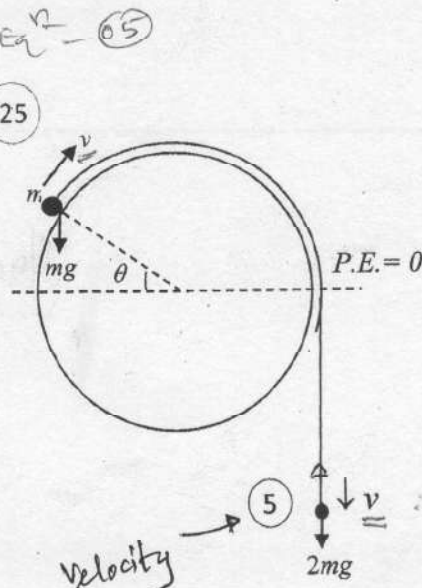

35

PAPERMASTER.LK

$$v = u \text{ when } \theta = \frac{\pi}{6} \text{ is given by } u^2 = \frac{2ag}{3} \left(\frac{\pi}{3} - \frac{1}{2} \right) \quad (10)$$

$$= \frac{ag}{9} (2\pi - 3).$$

Any by

By the conservation of energy

$$\frac{1}{2}mw^2 - mga = mg\frac{a}{2} + \frac{1}{2}mu^2 \quad (10)$$

$$\frac{1}{2}mw^2 = \frac{3mga}{2} + \frac{1}{2}m\frac{ag}{9}(2\pi - 3)$$

$$\frac{1}{2}mw^2 = \frac{1}{2}mag \left[3 - \frac{1}{3} + \frac{2\pi}{9} \right]$$

$$w^2 = ag \left[\frac{8}{3} + \frac{2\pi}{9} \right] = \frac{ag}{9} [24 + 2\pi]$$

$$w = \frac{\sqrt{2ga(\pi + 12)}}{3} \quad (5)$$

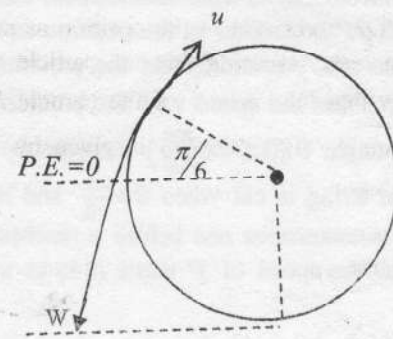
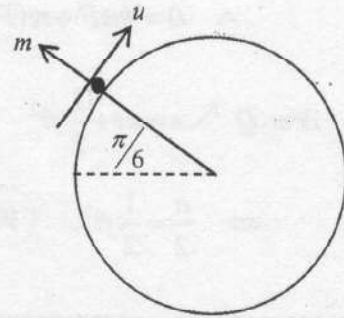

25

PAPERMASTER.LK

Q12 →

90	35	25
----	----	----

13. One end of a light elastic string of natural length $2a$ and modulus of elasticity $2mg$ is attached to a fixed point O which is at a distance of $4a$ above a smooth horizontal floor, and the other end to a particle P of mass m . The particle P hangs in equilibrium at B . Show that the extension of the string is a .

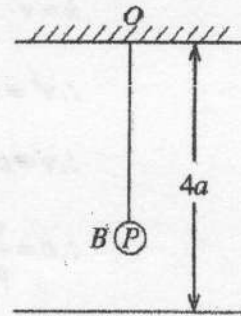

Now, the particle P is given an impulse of mv vertically downwards.

Show that the equation of motion of P is $\ddot{x} + \omega^2 x = 0$ where $\omega = \sqrt{\frac{g}{a}}$ and $BP = x$.

Using the formula $\dot{x}^2 = \omega^2(c^2 - x^2)$, where c is the amplitude, show that if $v > \sqrt{ag}$, P hits the floor.

Now, suppose that $v = 3\sqrt{ag}$.

Find the velocity with which P hits the floor.

The coefficient of restitution between P and the floor is e . If $e < \frac{1}{\sqrt{2}}$, show that the particle P will not reach O .

If it is given that $e = \frac{1}{2}$, find the velocity of P when the string becomes slack for the first time.

Find the total time taken by P to come to instantaneous rest for the first time, from the instant it was given the impulse at B .

At the equilibrium position,

$$2mg \cdot \frac{x}{2a} = mg. \quad (5)$$

$$\therefore x = a. \quad (5)$$

\therefore The extension of the string is a .

10

Apply $F = ma$:

$$\downarrow m \ddot{x} = mg - 2mg \frac{(a+x)}{2a} \quad (15) / 6$$

$$\ddot{x} = -\frac{g}{a} x \quad (5)$$

$$\therefore \ddot{x} + \omega^2 x = 0, \text{ where } \omega = \sqrt{\frac{g}{a}}.$$

20

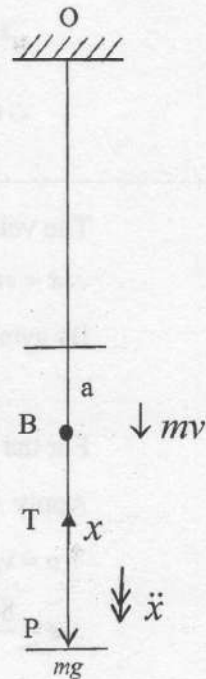

$$\dot{x} = v \text{ when } x = 0$$

$$\therefore v^2 = \omega^2 (c^2 - 0) \quad (5)$$

$$\therefore v = c\omega$$

$$\therefore c = \frac{v}{\omega} \quad (5)$$

$$\text{if } v > \sqrt{ag}, \text{ then } c > \sqrt{ag} \cdot \sqrt{\frac{a}{g}} = a \quad (10)$$

and hence the particle hits the floor.

20

Let, $\dot{x} = u$, where $x = a$.

Then

$$u^2 = \frac{g}{a} (9a^2 - a^2) = 8ag, \text{ since } c = \frac{v}{\omega} = 3a. \quad (10)$$

$$\therefore u = \sqrt{8ag}. \quad (5)$$

20

The velocity just after P hit the floor = $eu \uparrow$. (5)

$\therefore \dot{x} = eu$, when $x = a$.

By symmetry of S.H.M. about the center, $\dot{x} = eu$, when $x = -a$. (15)

For the motion of P under gravity,

Apply $v^2 = u^2 + 2as$:

$$\uparrow 0 = v_1^2 - 2gs \quad (5)$$

$$\therefore s = \frac{8e^2 ag}{2g} = 4e^2 a \quad (5)$$

If $e < \frac{1}{\sqrt{2}}$, then $s < 2a$ and P will not reach O . (10)

40

When $e = \frac{1}{\sqrt{2}}$, $v_1 = \sqrt{8e^2 ag} = \sqrt{2ag}$ (10)

10

Time taken to hit the floor, $T_1 = \frac{\sin^{-1}\left(\frac{1}{3}\right)}{\sqrt{\frac{g}{a}}} \quad (10)$
 $= \sqrt{\frac{a}{g}} \sin^{-1}\left(\frac{1}{3}\right)$

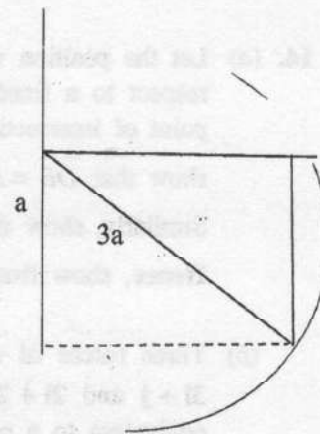

Let $e = \frac{1}{2}$. Then $C_1 = \sqrt{3}a$.

Time taken after that to reach the natural

Length $T_2 = \frac{2 \sin^{-1}\left(\frac{1}{\sqrt{3}}\right)}{\sqrt{\frac{g}{a}}} \quad (10)$

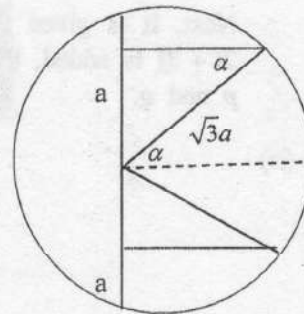

During is free flight : $\uparrow V = u + at$.

\therefore Time in free flight $T_3 = \frac{\sqrt{2ag}}{g} = \sqrt{\frac{2a}{g}} \quad (5)$

Total time taken $T_1 + T_2 + T_3 = \sqrt{\frac{a}{g}} \left(\sin^{-1}\left(\frac{1}{3}\right) + 2 \sin^{-1}\left(\frac{1}{\sqrt{3}}\right) + \sqrt{2} \right) \quad (5)$

30

$w t_1 = \frac{R}{2} \alpha$
 $t_1 = \sqrt{\frac{R}{g}} \left(\frac{R}{2} \rightarrow \cos^{-1}\left(\frac{1}{3}\right) \right)$

$\cos \beta = \frac{1}{\sqrt{3}}$

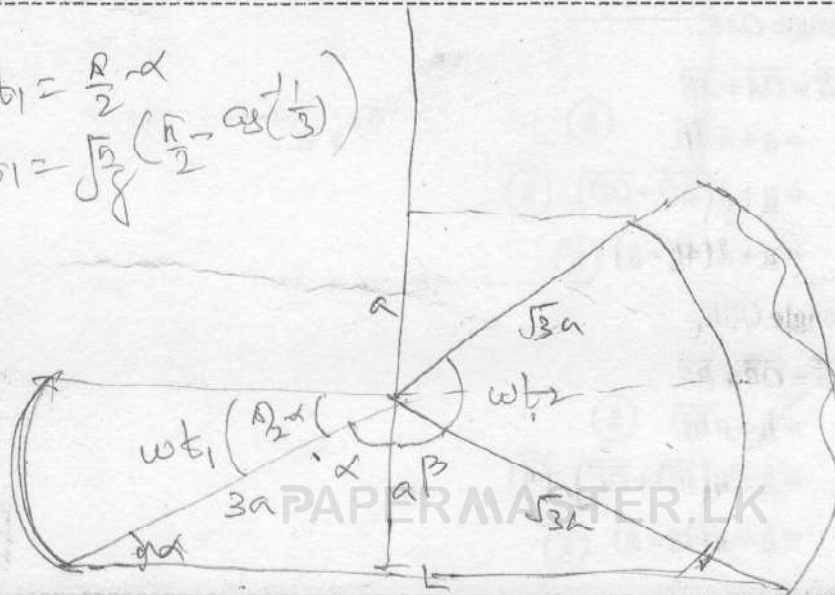

$w t_2 = R - 2\beta$
 $t_2 = \sqrt{\frac{R}{g}} \left(R - 2\cos^{-1}\left(\frac{1}{\sqrt{3}}\right) \right)$

Q13 = 7

10	20	20	20	40	10	30
----	----	----	----	----	----	----

14. (a) Let the position vectors of four points A, B, C and D be $\mathbf{a}, \mathbf{b}, 3\mathbf{a}$ and $4\mathbf{b}$, respectively with respect to a fixed origin O , where \mathbf{a} and \mathbf{b} are non-zero and non-parallel vectors. E is the point of intersection of AD and BC . Using the triangle law of addition for the triangle OAE , show that $\overrightarrow{OE} = \mathbf{a} + \lambda(4\mathbf{b} - \mathbf{a})$ for $\lambda \in \mathbb{R}$.

Similarly, show also that $\overrightarrow{OE} = \mathbf{b} + \mu(3\mathbf{a} - \mathbf{b})$ for $\mu \in \mathbb{R}$.

Hence, show that $\overrightarrow{OE} = \frac{1}{11}(9\mathbf{a} + 8\mathbf{b})$.

- (b) Three forces $\alpha\mathbf{i} + 2\mathbf{j}$, $-3\mathbf{i} + \beta\mathbf{j}$ and $\mathbf{i} + 5\mathbf{j}$ act through the points with position vectors $\mathbf{i} + \mathbf{j}$, $3\mathbf{i} + \mathbf{j}$ and $2\mathbf{i} + 2\mathbf{j}$, respectively, where $\alpha, \beta \in \mathbb{R}$. It is given that this system of forces is equivalent to a couple. Find the values of α and β , and the moment of this couple.

Now, a new force $3\gamma\mathbf{i} + 4\gamma\mathbf{j}$ acting through the origin O is added to the above system of forces, where $\gamma > 0$. Show that the new system consisting of 4 forces is equivalent to a resultant force and, find its magnitude, direction and the equation of its line of action.

Next, it is given that when a force $p\mathbf{i} + q\mathbf{j}$ acting through the point with position vector $2\mathbf{i} + 3\mathbf{j}$ is added, the system consisting of 5 forces is in equilibrium. Find the values of γ, p and q .

(a)

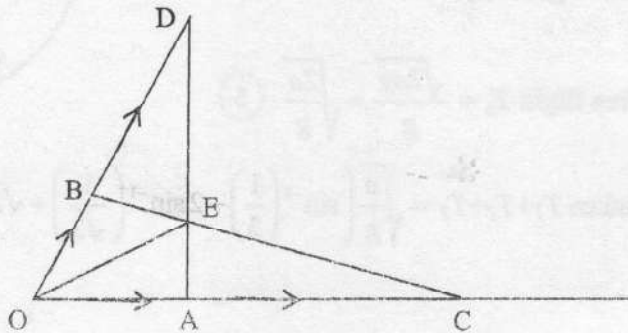

By the triangle OAE ,

$$\begin{aligned} \overrightarrow{OE} &= \overrightarrow{OA} + \overrightarrow{AE} \\ &= \mathbf{a} + \lambda \overrightarrow{AD} \quad (5) \\ &= \mathbf{a} + \lambda(\overrightarrow{AO} + \overrightarrow{OD}) \quad (5) \\ &= \mathbf{a} + \lambda(4\mathbf{b} - \mathbf{a}) \quad (5) \end{aligned}$$

By the triangle OBE ,

$$\begin{aligned} \overrightarrow{OE} &= \overrightarrow{OB} + \overrightarrow{BE} \\ &= \mathbf{b} + \mu \overrightarrow{BC} \quad (5) \\ &= \mathbf{b} + \mu(\overrightarrow{BO} + \overrightarrow{OC}) \quad (5) \\ &= \mathbf{b} + \mu(3\mathbf{a} - \mathbf{b}) \quad (5) \end{aligned}$$

30

$$\therefore \underline{a} + \lambda(4\underline{b} - \underline{a}) = \underline{b} + \mu(3\underline{a} - \underline{b}) \quad (5)$$

$$(1 - \lambda)\underline{a} + 4\lambda\underline{b} = 3\mu\underline{a} + (1 - \mu)\underline{b} \quad (5)$$

$$\Rightarrow 1 - \lambda = 3\mu \text{ and } 1 - \mu = 4\lambda \quad (5)$$

$$\therefore \lambda = \frac{2}{11} \quad (5)$$

$$\therefore \overline{OE} = \underline{a} + \frac{2}{11}(4\underline{b} - \underline{a}) \quad (5)$$

$$= \frac{1}{11}(9\underline{a} + 8\underline{b}). \quad (5)$$

*If not used for next question
Less - 05*

60

30
~~60~~

(b)

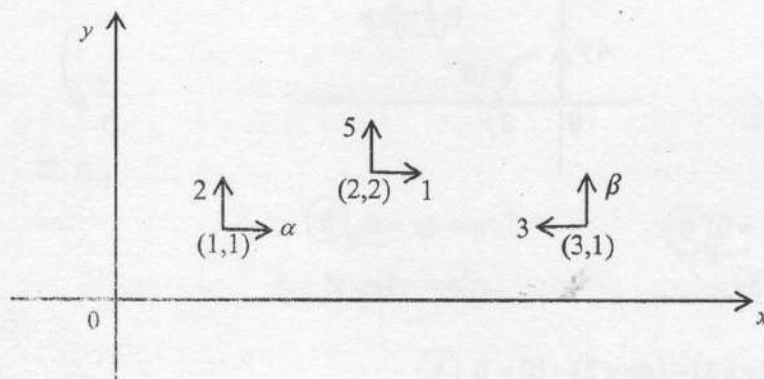

Since the system is equivalent to a couple,

$$\rightarrow X = 0, \quad \uparrow Y = 0 \text{ and } G \neq 0.$$

$$X = \alpha - 3 + 1 = 0. \quad (5)$$

$$\Rightarrow \alpha = 2 \quad (5)$$

$$Y = 2 + \beta + 5 = 0. \quad (5)$$

$$\Rightarrow \beta = -7 \quad (5)$$

20

$$\curvearrowright G = 2(1) - 2(1) + 3(1) - 7(3) + 5(2) - 1(2) \quad (5)$$

$$= 3 - 21 + 10 - 2$$

$$= 13 - 23$$

$$= -10. \quad (5)$$

10

$$R^2 = 9\gamma^2 + 16\gamma^2 \quad (5)$$

$$= 25\gamma^2$$

$$\therefore R = 5\gamma \quad (5)$$

$$\tan \theta = \frac{4\gamma}{3\gamma} = \frac{4}{3} \quad (5)$$

$$\therefore \theta = \tan^{-1}\left(\frac{4}{3}\right) \quad (5)$$

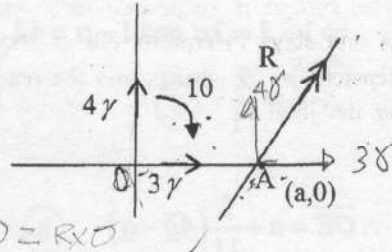

A) $4\gamma a + 10 = 0 \Rightarrow R \perp OA \Rightarrow 4\gamma a + 10 = R \times 0$

$$\therefore a = \frac{-5}{2\gamma} \quad (5)$$

$$a = \frac{-5}{2\gamma}$$

The equation the line of action $4x - 3y + \frac{10}{\gamma} = 0$ (5)

30

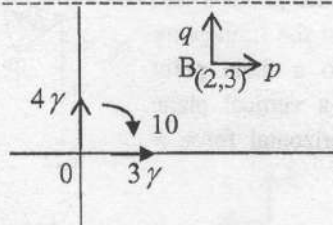

$$10 =$$

$$\rightarrow p + 3\gamma = 0 \quad (5)$$

$$\therefore p = -3\gamma$$

$$\uparrow q + 4\gamma = 0 \quad (5)$$

$$\therefore q = -4\gamma$$

B) $(3\gamma \times 3) - (4\gamma \times 2) - 10 = 0 \quad (5)$

$$\therefore \gamma = 10 \quad (5)$$

$$\therefore p = -30 \quad (5) \quad \text{and} \quad q = -40 \quad (5)$$

30

Aliter

O) $q(2) - 3p - 4r(x) = 0 \quad (5)$

$$2q - 3p - 4r\left(\frac{5}{2r}\right) = 0 \quad (5)$$

$$2q - 3p - 10 = 0$$

O) $\uparrow q + 4\gamma = 0 \Rightarrow q = -4\gamma \quad (5)$

$$\rightarrow p + 3\gamma = 0 \Rightarrow p = -3\gamma \quad (5)$$

$$2(-4\gamma) - 3(-3\gamma) = 10$$

$$-8\gamma + 9\gamma = 10$$

$$\gamma = 10$$

$$p = -30 \quad \& \quad q = -40$$

$$(5)$$

$$(5)$$

30

Q1a 20/20 | 20/20 | 30/30

- 15.(a) Four uniform rods AB , BC , CD and DA each of length $2a$ and weight W are smoothly jointed at their ends A , B , C and D . The midpoints of AB and BC are joined by a light inextensible string of length a . Similarly, midpoints of AD and DC are also joined by a light inextensible string of length a . The system is suspended in a vertical plane from the point A and stays in equilibrium as shown in the figure. Find the tensions in the strings and the reaction exerted on AB by BC at the joint B .

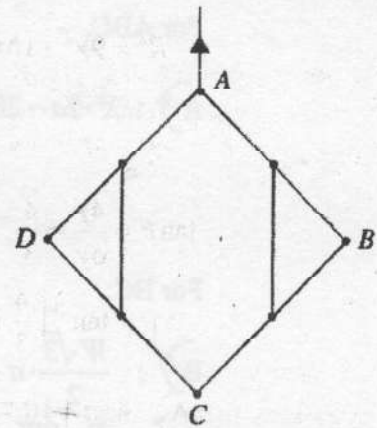

- (b) The framework shown in the figure consists of five light rods AB , BC , CD , DA and DB smoothly jointed at their ends. It is given that $AD = a$, $AB = \sqrt{3}a$, $\hat{BAD} = 90^\circ$, $\hat{CBD} = 90^\circ$ and $\hat{BDC} = 60^\circ$. At each of the joints B and C , a load W is suspended and the framework is smoothly hinged at A to a fixed point and kept in equilibrium in a vertical plane with AB horizontal by a horizontal force P applied to it at the joint D .

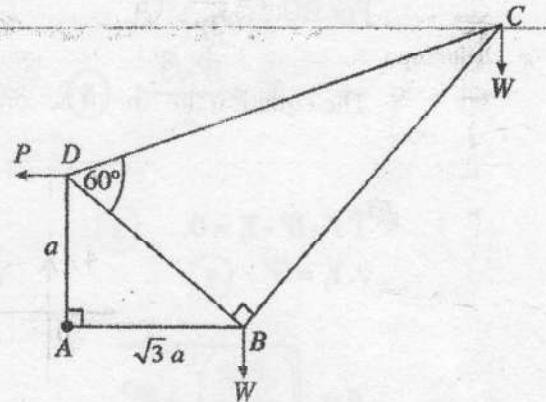

- (i) Find the value of P .
 (ii) Draw the stress diagram using Bow's notation for the joints C , B and D .
 Hence, find the stresses in the rods, stating whether they are tensions or thrusts.

(a)

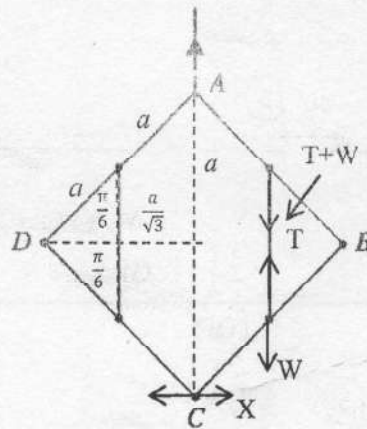

By symmetry, the reaction at C from DC on CB is horizontal.

5

PAPERMASTER.LK

For ABC,

$$A) : X \cdot 2a - 2W \cdot \frac{a\sqrt{3}}{2} = 0 \quad (5)$$

$$X = \frac{\sqrt{3}W}{2} \quad (5)$$

For BC:

$$B) : \frac{W\sqrt{3}}{2} \cdot a + W \cdot \frac{a\sqrt{3}}{2} - T \cdot \frac{a\sqrt{3}}{2} = 0 \quad (10) / 6$$

$$T = 2W \quad (5)$$

For BC:

$$\rightarrow X_1 = \frac{W\sqrt{3}}{2}; \quad (5)$$

$$\uparrow T - W - Y_1 = 0 \quad (5)$$

$$\therefore Y_1 = W \quad (5)$$

$$R = \sqrt{\left(\frac{\sqrt{3}W}{2}\right)^2 + W^2}$$

$$= \frac{\sqrt{7}W}{2} \quad (5)$$

$$\tan \theta = \frac{Y_1}{X_1} = \frac{W}{\frac{W\sqrt{3}}{2}} = \frac{2}{\sqrt{3}}$$

$$\therefore \theta = \tan^{-1}\left(\frac{2}{\sqrt{3}}\right) \quad (5)$$

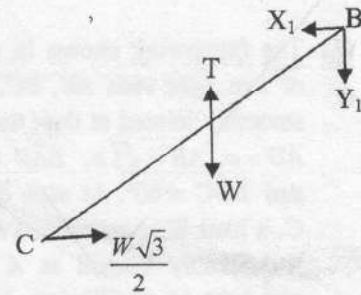

55

(b) $\vec{A} \rightarrow P \times a - W \times \sqrt{3}a - W \times 2\sqrt{3}a = 0$ (10)
 $\therefore P = 3\sqrt{3}W$. (5)

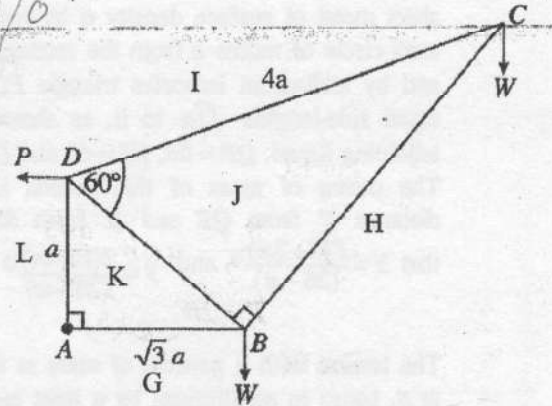
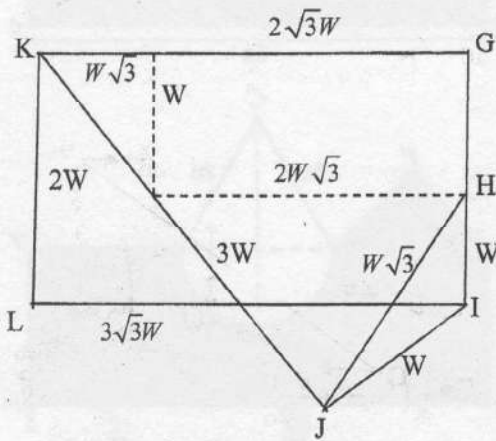

- joint C: (10)
- joint D: (10)
- joint B: (10)

Rod	Stress	Tension	Manganite	
AB	✓	-	$3\sqrt{3}W$	(10)
BC	✓	-	$\sqrt{3}W$	(10)
CD	-	✓	W	(10)
BD	-	✓	5W	(10)
AD	✓	-	2W	(10)

Q15 ⇒ 55 | 95

16. Show that the centre of mass of a uniform semi-circular lamina of radius r and centre O is at a distance $\frac{4r}{3\pi}$ from O .

A plane lamina is made from a uniform thin sheet metal of surface density σ by removing a semi-circle of radius a from the rectangle $QRST$ and by adding an isosceles triangle PQW with equal side-lengths $\sqrt{2}a$ to it, as shown in the adjoining figure. $QR = 2a$, $RS = 6a$ and $QW = 2a$. The centre of mass of this lamina lies at a distance \bar{x} from QR and \bar{y} from RS . Show that $\bar{x} = \frac{(74 - 3\pi)a}{(26 - \pi)}$ and $\bar{y} = \frac{2(15 - \pi)a}{(26 - \pi)}$.

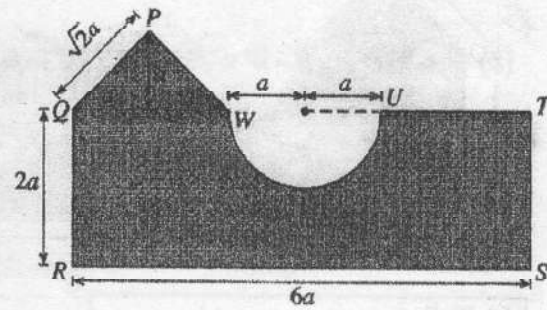

The lamina with a particle of mass m fixed to it at S , hangs in equilibrium by a light inextensible string of length $4a$ whose ends are attached to U and W and passing over a small smooth fixed peg C with side RS horizontal as shown in the figure. Find the value of m and the tension of the string in terms of a and σ .

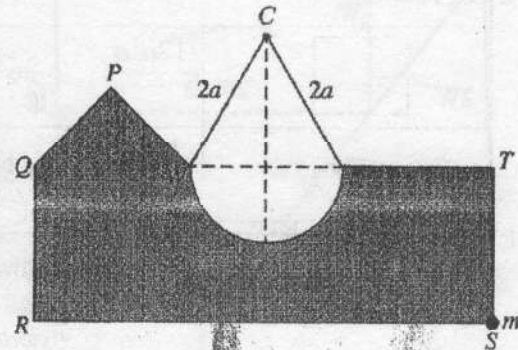

By Symmetry, $\bar{y} = 0$ (5)

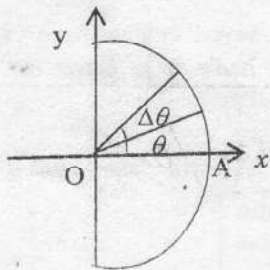

$$\Delta m = \frac{1}{2} r^2 \Delta \theta \times \sigma$$

$$\int_{-\pi/2}^{\pi/2} \frac{1}{2} r^2 \sigma \cdot \frac{2}{3} r \cos \theta d\theta \quad (5)$$

$$\bar{x} = \frac{\int_{-\pi/2}^{\pi/2} \frac{1}{2} r^2 \sigma \cdot d\theta}{\int_{-\pi/2}^{\pi/2} \frac{1}{2} r^2 \sigma \cdot d\theta} \quad (5)$$

$$\frac{2}{3} r^3 \sin \theta \Big|_{-\pi/2}^{\pi/2} \quad (5)$$

$$\frac{1}{2} r^2 \theta \Big|_{-\pi/2}^{\pi/2} \quad (5)$$

$$= \frac{4r}{3\pi} \quad (5)$$

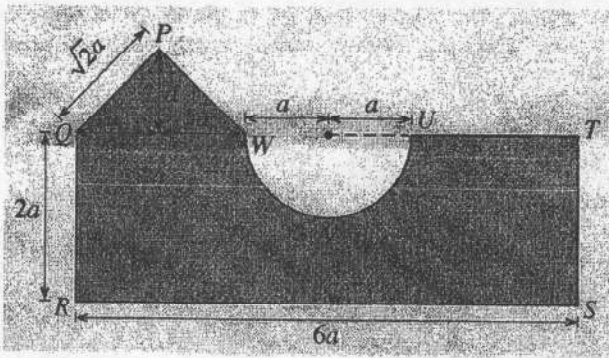

Objects	Mass	Distance from QR	Distance from RS
	$12a^2\sigma$	$3a$	a
	$\frac{1}{2}\pi a^2\sigma$	$3a$	$2a - \frac{4a}{3\pi}$
	$\frac{1}{2}(2a)a\sigma$ $= a^2\sigma$	a	$2a + \frac{1}{3}a = \frac{7a}{3}$
	$12a - \frac{1}{2}\pi + a^2\sigma$ $(13 - \frac{\pi}{2})a^2\sigma$	\bar{x}	\bar{y}

(15)
(15)
(15)

$$\begin{aligned} (13 - \frac{\pi}{2})a^2\sigma\bar{x} &= 12a^2\sigma(3a) - \frac{1}{2}\pi a^2\sigma(3a) + a^2\sigma(a) \quad (15) / 0 \\ \Rightarrow (26 - \pi)a^2\sigma\bar{x} &= 72a^3\sigma - \frac{3}{2}\pi a^3\sigma + 2a^3\sigma \\ \Rightarrow \bar{x} &= \frac{(74 - 3\pi)a}{(26 - \pi)} \quad (5) \end{aligned}$$

$$\begin{aligned} (13 - \frac{\pi}{2})a^2\sigma\bar{y} &= 12a^2\sigma(a) - \frac{1}{2}\pi a^2\sigma(2a - \frac{4a}{3\pi}) + a^2\sigma(\frac{7a}{3}) \quad (15) / 0 \\ \Rightarrow (\frac{26 - \pi}{2})a^2\sigma\bar{y} &= 12a^3\sigma - \pi a^3\sigma + \frac{2a^3\sigma}{3} + \frac{7a^3\sigma}{3} \quad (5) \\ &= \frac{45a^3\sigma - 3\pi a^3\sigma}{3} \\ \bar{y} &= \frac{2(15 - \pi)a}{(26 - \pi)} \quad (5) \end{aligned}$$

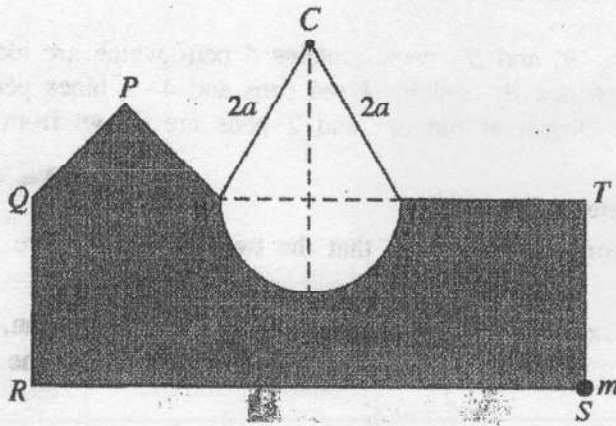

c) :

$$mg(3a) = \left(13 - \frac{\pi}{2}\right) a^2 \sigma g(3a - \bar{x}) \quad (10)$$

$$m = \frac{(26 - \pi)}{6} a \sigma \left(3a - \frac{(74 - 3\pi)a}{26 - \pi}\right) \quad (5)$$

$$= \frac{a^2 \sigma}{2} (4a + 3\pi a - 3\pi a)$$

$$m = \frac{2a^2 \sigma}{3} \quad (5)$$

$$\uparrow \quad 2T \cos \frac{\pi}{6} = mg + \left(13 - \frac{\pi}{2}\right) a^2 \sigma g \quad (5)$$

$$\Rightarrow \quad \sqrt{3} T = \frac{2}{3} a^2 \sigma g + 13a^2 \sigma g - \frac{\pi}{2} a^2 \sigma g$$

$$= \frac{41a^2 \sigma g}{3} - \frac{\pi a^2 \sigma g}{2}$$

$$T = \frac{(82 - 3\pi) a^2 \sigma g}{6\sqrt{3}} \quad (5)$$

30

PAPERMASTER.LK

Q16 ⇒

30	90	30
----	----	----

17.(a) Four identical boxes B_1, B_2, B_3 and B_4 , each contains 4 pens which are identical in all aspects except for their colour. Each box B_k contains k red pens and $4-k$ black pens for $k = 1, 2, 3, 4$. One of the four boxes is chosen at random and 2 pens are drawn from that box. Find the probability that

- (i) the two pens drawn are red,
- (ii) the pens are drawn from box B_4 , given that the two pens drawn are red.

(b) The data sets $\{x_1, x_2, \dots, x_n\}$ and $\{y_1, y_2, \dots, y_m\}$ have the same mean, and their standard deviations are σ_x and σ_y , respectively. Show that the variance of the combined data set

$\{x_1, \dots, x_n, y_1, \dots, y_m\}$ is given by $\frac{n\sigma_x^2 + m\sigma_y^2}{n+m}$.

Diameters of bolts produced at a factory is summarised in the following table:

Diameter (mm)	Number of bolts (in thousands)
2-6	2
6-10	5
10-14	8
14-18	4
18-22	1

Estimate the mean, the median and the variance of the distribution given above.

The diameters of another 40 000 bolts produced by a neighboring factory has the same mean, while the variance is 22.53 mm^2 . Estimate the combined variance of the diameters of the bolts produced by both factories.

(a)

$$P(RR) = P(RR|B_1)P(B_1) + P(RR|B_2)P(B_2) + P(RR|B_3)P(B_3) + P(RR|B_4)P(B_4) \quad (10)$$

$$= 0 \cdot \frac{1}{4} + \frac{{}^2C_2}{4} \cdot \frac{1}{4} + \frac{{}^3C_2}{4} \cdot \frac{1}{4} + \frac{{}^4C_2}{4} \cdot \frac{1}{4} \quad (20)$$

$$= \frac{1}{4 \cdot {}^4C_2} [1+3+6]$$

$$= \frac{10}{24} = \frac{5}{12} \quad (5)$$

$$P(B_4|RR) = \frac{P(B_4|RR)P(B_4)}{P(RR)} \quad (10)$$

$$= \frac{1 \cdot \frac{1}{4}}{5} \quad (5)$$

$$= \frac{5}{12} \quad (5)$$

$$= \frac{12}{20} = \frac{3}{5} \quad (5)$$

$$P(B_4|RR) = \frac{P(RR|B_4)P(B_4)}{P(RR)}$$

(b)

Let μ be the mean of each the data sets $\{x_1, x_2, \dots, x_n\}$ and $\{y_1, y_2, \dots, y_m\}$.

Then the mean of the combined data set is also μ . (5)

Set;

$$\sigma^2 = \frac{\sum_{i=1}^n x_i^2 + \sum_{i=1}^m y_i^2}{n+m} - \mu^2 \quad (5)$$

$$= \left[\frac{\sum_{i=1}^n x_i^2 - n\mu^2}{n+m} \right] + \left[\frac{\sum_{i=1}^m y_i^2 - m\mu^2}{n+m} \right] \quad (5)$$

$$= \frac{1}{n+m} \left[n \left(\frac{\sum_{i=1}^n x_i^2}{n} - \mu^2 \right) + m \left(\frac{\sum_{i=1}^m y_i^2}{m} - \mu^2 \right) \right] \quad (5)$$

$$= \frac{n\sigma_x^2 + m\sigma_y^2}{n+m} \quad (5)$$

25

Diameter (mm)	$f(10^3)$	Mid. value x	xf	x^2f
2 - 6	2	4	8	32
6 - 10	5	8	40	320
10 - 14	8	12	96	1152
14 - 18	4	16	64	1024
18 - 22	1	20	20	400
	20		228	2928

(5)

(10)

(10)

$$\text{Mean} = \frac{\sum xf}{\sum f} = \frac{228}{20} = 11.4 \text{ mm} \quad (5)$$

$$\text{Variance} = \frac{\sum x^2 f}{\sum f} - \mu^2 = \frac{2928}{20} - (11.4)^2 = 146.4 - 129.96 = 16.44 \text{ mm}^2. \quad (5)$$

$$\text{Median} = 10 + \frac{(10-7)}{8} \times 4 = 11.5 \text{ mm}. \quad (5)$$

f	x	$y = \frac{1}{4}x$	$y^2 f y$	$f y$
2	4	1	1	2
5	8	2	4	10
8	12	3	9	24
4	16	4	16	16
1	20	5	25	5
			57	57

$$\bar{y} = \frac{\sum y f}{\sum f} = \frac{57}{20}$$

$$\bar{y} = \frac{1}{4} \bar{x} \Rightarrow \bar{x} = 4 \bar{y} = 4 \times \frac{57}{20} = 11.4$$

$$\begin{aligned} \text{Combined Variance} &= \frac{10}{20+40} \{20\sigma_1^2 + 40\sigma_2^2\} = \frac{1}{60} \{20 \times 16.44 + 40 \times 22.53\} \quad (5) \\ &= 20.5 \text{ mm}^2. \end{aligned}$$

65